

Invacare® TDX® SP2 Series



en Power Wheelchair
Service Manual



PROVIDER: Keep this manual.
The procedures in this manual MUST be performed by a qualified technician.



Yes, you can.®

© 2020 Invacare Corporation

All rights reserved. Reproduction, duplication or modification in whole or in part is prohibited without prior written permission from Invacare. Trademarks are identified by ™ and ®. All trademarks are owned by or licensed to Invacare Corporation or its subsidiaries unless otherwise noted.

Invacare reserves the right to alter product specifications without further notice.

Contents

1 General	4
1.1 About this manual	4
1.2 General Information	4
1.3 Notes on Shipping	4
1.4 Symbols in This Manual	4
1.5 Images in This Manual	4
2 Safety	5
2.1 Safety and Fitting Instructions	5
3 Hygiene	7
3.1 Handling of Returned Used Products	7
4 Setup	8
4.1 Adjusting seating position	8
4.1.1 Adjusting Lower Leg Length	8
4.1.2 Adjusting seat depth	8
4.1.3 Adjusting center of gravity of seat	8
4.2 Modulite seat	9
4.2.1 Telescopic seat frame	9
4.2.2 One-Piece Seat Plate	9
4.3 Imperial to metric conversion chart	9
5 Testing	11
5.1 Testing Motor	11
5.2 Testing Motor Brake	11
5.3 Rain test	11
5.4 Field Load Test	12
5.5 Checking Battery Charge Level	12
6 Service	14
6.1 General Warning Information on Installation Work	14
6.2 Tightening torques	14
6.3 Troubleshooting	14
6.3.1 Operational Faults	14
6.3.2 Drive Fault Diagnosis	14
6.3.3 Charging device fault diagnosis	18
6.4 Service Plan (Once a Year)	19
6.5 Overview mobility device	21
6.6 Chassis	22
6.6.1 Overview of Components	22
6.6.2 Stability lock	22
6.6.3 Top Walking Beam	24
6.6.4 Bottom Walking Beam	25
6.6.5 Steering head front	25
6.6.6 Removing rear springs	26
6.6.7 Installing rear springs	26
6.6.8 Replacing battery tray	27
6.6.9 Replacing battery box	27
6.6.10 Replacing Rubber Stopper	28
6.6.11 Replacing Tie-Down Adapter (Low-Rider)	28
6.7 Drive Components	29
6.7.1 Overview Motor/Gearbox Unit	29
6.7.2 Replacing Motor/Gearbox Unit	29
6.7.3 Replacing or rotating motor/gearbox unit sealing ring	30
6.7.4 Replacing motor/gearbox clutch	30
6.7.5 Replacing carbon brushes	31
6.7.6 Removing Rear Suspension	32
6.7.7 Removing rear suspension – alternative method	32
6.7.8 Refitting rear suspension	32
6.7.9 Refitting rear suspension – alternative method	33
6.7.10 Replacing caster fork	33
6.7.11 Adjusting caster fork	34
6.8 Wheels	34
6.8.1 Repair Instructions	34
6.8.2 Tyre Pressure	35
6.8.3 Tyre Types	35
6.8.4 Specific Tightening Torques	35
6.8.5 Overview of Power Wheelchair Models and Wheel Types	36
6.8.6 Replacing rim inserts in drive wheels	38
6.8.7 Replacing Tyres	38
6.8.8 Replacing Drive Wheel (5–Screw Installation)	39
6.8.9 Replacing drive wheel hub	40
6.8.10 Replacing Castor Wheel on Double-Sided Fork	40
6.8.11 Replacing Castor Wheels on Single-Sided Fork	41
6.9 Shrouds	42
6.9.1 Removing front shroud	42
6.9.2 Replacing Rear Shroud (Without Operating Hour Counter)	42
6.9.3 Replacing Rear Shroud (With Operating Hour Counter)	42
6.9.4 Removing top shroud	43
6.9.5 Replacing fender	43
6.10 Controls	43
6.10.1 Replacing Power Module	43
6.10.2 Replacing Tilt Actuator (“Fixed Pivot” Tilt)	44
6.10.3 Replacing G-Trac Sensor	44
6.10.4 Replacing Operating Hour Counter/ Connecting Cable	45
6.10.5 Updating Software	46
6.10.6 Replacing USB charger	46
6.10.7 Checking cable	46
6.10.8 Cable routing	46
6.11 Batteries	47
6.11.1 General Instructions on Handling Batteries	47
6.11.2 Handling Damaged Batteries Correctly	47
6.11.3 Making Batteries Accessible	48
6.11.4 Replacing Batteries (60 Ah / 73 Ah)	48
6.11.5 Replacing Batteries (50 Ah)	49
6.11.6 Replacing Batteries / Battery Cables	49
6.11.7 Checking and replacing main fuse	50
6.12 Lighting unit	50
6.12.1 Replacing front bulb (conventional lighting system)	50
6.12.2 Replacing headlight complete (conventional lighting system)	51
6.12.3 Replacing headlight complete (LED lighting system)	51
6.12.4 Replacing front lamp holder (conventional lighting system)	51
6.12.5 Replacing front lamp holder - (conventional lighting system)	52
6.12.6 Replacing front lamp holder - (LED lighting system)	52
6.12.7 Replacing rear bulb (conventional lighting system)	52
6.12.8 Replacing rear light complete - (conventional lighting system)	52
6.12.9 Replacing complete rear light - (LED lighting system)	53
6.12.10 Replacing rear lamp holder - (conventional lighting system)	53
6.13 Seating	54
6.14 Mounting Dahl Docking System	54

1 General

1.1 About this manual

- This manual refers to configurations with Modulite seat system. Older specifications have been described in revision 11 of this service manual.
- For seat systems, refer to the corresponding manual.
- For Shark, DX, DX2, refer to revision 11 of this service manual.
- For LiNX controls, refer to LiNX Service Manual.

1.2 General Information

Service and maintenance work must be carried out taking this document into account.

It is imperative that you observe safety information.

Information about operation or about general maintenance and care work on the product should be taken from service manual.

Assembly of accessories might not be described in this document. Refer to the manual delivered with the accessory. Additional manuals can be ordered from Invacare. See addresses at the end of this document.

You can find information about ordering spare parts in the spare parts catalogue.

Spare parts must match original Invacare parts. Only use spare parts which have been approved by Invacare.

The product may only be maintained and overhauled by qualified personnel.

The minimum requirement for service technicians is suitable training, such as in the cycle or orthopedic mechanics fields, or sufficiently long-term job experience. Experience in the use of electrical measuring equipment (multimeters) is also a requirement. Special Invacare training is recommended.

Alterations to the mobility device which occur as a result of incorrectly or improperly executed maintenance or overhaul work lead to the exclusion of all liability on the side of Invacare.

If you have any problems or questions contact your provider.

1.3 Notes on Shipping

- If the mobility device has to be shipped back to the manufacturer for major repairs, you should always use the original packaging for transport.
- Please attach a precise description of the fault.

1.4 Symbols in This Manual

Symbols and signal words are used in this manual and apply to hazards or unsafe practices which could result in personal injury or property damage. See the information below for definitions of the signal words.



WARNING

Indicates a hazardous situation that could result in serious injury or death if it is not avoided.



CAUTION

Indicates a hazardous situation that could result in minor or slight injury if it is not avoided.



IMPORTANT

Indicates a hazardous situation that could result in damage to property if it is not avoided.



Tips

Gives useful tips, recommendations and information for efficient, trouble-free use.



Tools

Identifies required tools, components and items which are needed to carry out certain work.

1.5 Images in This Manual

The detailed images in this manual are given marks to identify various components. Component marks in text and operational instructions always relate to the image directly above.

2 Safety

2.1 Safety and Fitting Instructions

These safety instructions are intended to prevent accidents at work, and it is imperative that they are observed.

Before any inspection or repair work

- Read and observe this repair manual and the associated user manual.
- Observe the minimum requirements for carrying out the work (see 1.2 *General Information, page 4*).

Personal Safety Equipment

Safety shoes

The mobility device, and some of its components, are very heavy. These parts can result in injuries to the feet if they are allowed to drop.

- Wear standardized safety shoes during all work.

Eye protection

It is possible that battery acid can be discharged when working on defective batteries or when handling batteries improperly.

- Always wear eye protection when working on any defective or possibly defective batteries.

Safety gloves

It is possible that battery acid can be discharged when working on defective batteries or when handling batteries improperly.

- Always wear acid-proof safety gloves when working on any defective or possibly defective batteries.

General Safety Information and Information About Fitting / Removal



DANGER!

Risk of Death, Serious Injury, or Damage

Lighted cigarettes dropped onto an upholstered seating system can cause a fire resulting in death, serious injury, or damage. Mobility device occupants are at particular risk of death or serious injury from these fires and resulting fumes because they may not have the ability to move away from the mobility device.

- DO NOT smoke while using this mobility device.



WARNING!

Risk of Serious Injury or Damage

Storing or using the mobility device near open flame or combustible products can result in serious injury or damage.

- Avoid storing or using the mobility device near open flame or combustible products.



CAUTION!

Risk of crushing

Various components such as the drive unit, batteries, seat etc are very heavy. This results in injury hazards to your hands.

- Note the high weight of some components. This applies especially to the removal of drive units, batteries and the seat.



CAUTION!

Injury hazard if the mobility device starts moving unintentionally during repair work

- Switch the power supply off (ON/OFF key).
- Engage the drive.
- Before lifting up, secure the mobility device by using chocks to block the wheels.



CAUTION!

Fire and burn hazard due to electrical short-circuit

- The mobility device must be completely switched off before removal of voltage-carrying components! To do this, remove the batteries.
- Avoid short-circuiting the contacts when carrying out measurements on voltage-carrying components.



CAUTION!

Risk of burns from hot surfaces on the motor

- Allow the motors to cool down before commencing work on them.



CAUTION!

Injury hazard and risk of damage to mobility device due to improper or incomplete maintenance work

- Use only undamaged tools in good condition.
- Some moving parts are mounted in sockets with PTFE coating (Teflon™). Never grease these sockets!
- Never use "normal" nuts instead of self-locking nuts.
- Always use correctly-dimensioned washers and spacers.
- When reassembling, always replace any cable ties which were cut during dismantling.
- After completing your work / before renewed start-up of the mobility device, check all connections for tight fitting.
- After completing your work / before renewed start-up of the mobility device, check all parts for correct locking.
- Only operate the mobility device with the approved tyre pressures (see technical data).
- Check all electrical components for correct function. Note that incorrect polarity can result in damage to the control system.
- Always carry out a trial run at the end of your work.



CAUTION!

Risk of injury and damage to property, if the maximum speed reduction on a wheelchair with a lifter does not function correctly

The wheelchair's control unit must reduce the maximum possible speed as soon as the lifter is raised.

- Test the maximum speed reduction for correct function after any maintenance work or modifications to the wheelchair.



CAUTION!

Any changes to the drive program can affect the driving characteristics and the tipping stability of the mobility device

- Changes to the drive program may only be carried out by trained Invacare providers.
- Invacare supplies all mobility devices with a standard drive program ex-works. Invacare can only give a warranty for safe mobility device driving behavior - especially tipping stability - for this standard drive program.



Mark all current settings for the mobility device (seat, armrests, backrest etc.), and the associated cable connecting plugs, before dismantling. This makes reassembly easier. All plugs are fitted with mechanical locks which prevent release of the connecting plugs during operation. To release the connecting plugs the safety locks must be pressed in. When reassembling ensure that these safety locks are correctly engaged.

3 Hygiene

3.1 Handling of Returned Used Products

When reconditioning or repairing returned mobility devices:

- Take precautions for yourself and the product.
- Use protection equipment as specified locally.

Before Transport (According to Biological Agents Ordinance)

Treat product according to following process steps:

Process Step	Component	Application	Conditioning technique	Work Station
Manual cleaning	Surface of used device	Before repair or reconditioning	Use saturated towel to apply cleaning detergent and remove residues after impact.	Cleaning and disinfection
Disinfection	Surface of used device	Before repair or reconditioning	Use saturated disinfectant wipes and clean* the device surface.	Cleaning and disinfection

*Invacare uses detergent "Nücosept special" 1.5% in water ml/ml

Disinfection Tools

- Disposable wipes (fleece)
- Brushes to clean areas difficult to access

Further Information

 For more information contact your Invacare service department.

4 Setup

4.1 Adjusting seating position

Adjusting the seating position in order to adapt the mobility device optimally to the requirements of the user, we recommend that you ask your authorised Invacare® dealer to adjust seat depth individually. Adapting the seat to the user's seating position depends on the seat that has been fitted, and should be carried out in the following sequence.

1. Adjusting the lower leg length and seat depth. See chapter 4.1.1 *Adjusting Lower Leg Length*, page 8 .
2. Adjusting the center of gravity of the seat frame. See chapter 4.1.3 *Adjusting center of gravity of seat*, page 8 .
3. Checking that the swivel castors can move freely.
4. Repetition of steps 2 to 4, if necessary.



WARNING!
Risk of injury after tilting of mobility caused by blocked steering wheels

- Always check the seat depth settings for both forward and reverse movement. Make sure that steering wheels can rotate freely and have not contact to any fixed mobility device component.



CAUTION!
Risk of tipping over

Any change in the seating position can negatively influence the stability of the mobility device.

- Always make sure that the mobility device is stable and will not tip over, after adjusting seating position.



WARNING!
Any changes to the drive program can affect the driving characteristics and the tipping stability of the mobility device

- Changes to the drive program may only be carried out by trained Invacare® providers.
- Invacare® supplies all mobility devices with a standard drive program ex-works. Invacare® can only give a warranty for safe vehicle driving behavior - especially the tipping stability - for this standard drive program.



WARNING!
Risk of crushing

The seat is very heavy. Risk of injury to hands and feet.

- Pay attention to the hand and feet.
- Use proper lifting techniques.

4.1.1 Adjusting Lower Leg Length

Invacare offers a range of legrests which can be adjusted individually. See user manual.

4.1.2 Adjusting seat depth

A: Seat depth

B: Center of gravity of the seat/ seat position

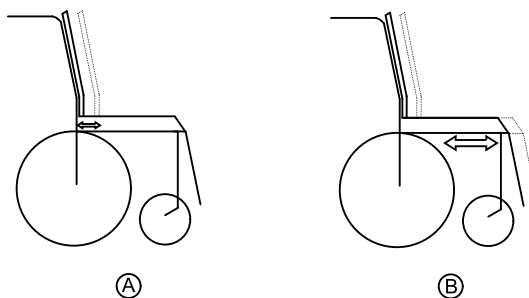

Seat depth **A** can be adjusted by moving backrest in relation to seat surface.

Modulite seat

The seat depth is adjusted by shifting the position of the backrest. See User Manual.

Seat systems

For details on

- Standard seat
- Flex seat
- Contour seat
- Max seat

refer to revision 11 of this service manual.

For details on Modulite seat see below.

4.1.3 Adjusting center of gravity of seat

The center of gravity of seat (CoG) can be adjusted by mounting seat frame farther towards front or the rear of seat.



CAUTION!
The seating system of the mobility device is delivered ex works with a standard adjustment of center of gravity (CoG), which meets 80–90% of user requirements. CoG can be adjusted individually. However, any change in this adjustment setting can negatively influence the stability of the power wheelchair.

- You must perform an individual risk analysis every time you change the center of gravity of the seating position, in order to ensure the safety and stability of the power wheelchair.

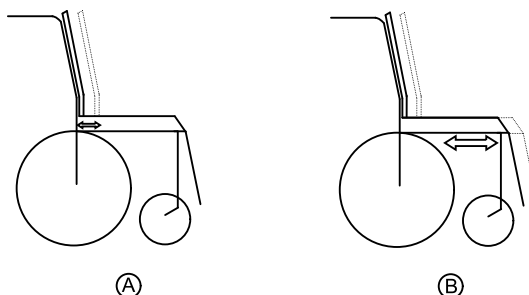

A: Seat depth

B: Center of gravity of the seat/ seat position

i The user weight and seat depth have strong influences on the choice of the center of gravity (CoG). If the user is heavy and the seat depth is greater, the focus should be the farther back. For best possible driving characteristics of rear-wheel drive wheelchairs, the weight should be distributed: 30 – 40 % front and 60 - 70 % rear. For center wheel drives the weight should be distributed 25% front, 50% center and 25% rear.

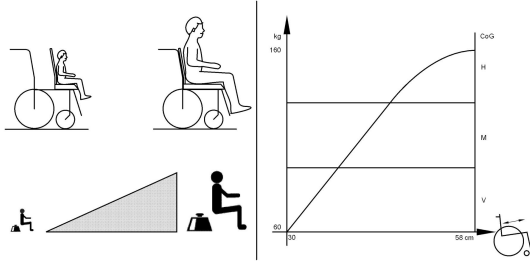

CAUTION!
Risk of damage due to collisions of the legrests with other parts of the mobility device
 – Set the legrests to the smallest angle before adjusting the seat center of gravity.
 – Pay attention with adjusting seat center of gravity that legrests do not touch any other parts of wheelchair. This ensures that the legrests can not collide with other parts of wheelchair.

Seat systems

For details on

- Standard seat
- Flex seat
- Contour seat
- Max seat

refer to revision 11 of this service manual.

For details on Modulite seat see below.

4.2 Modulite seat

The Modulite seat is available in two versions:

- Telescopic seat frame (plate and strap): Adjustment of center of gravity via the lateral profiles, as described below in “Telescopic seat frame”.
- One piece seat plate: Adjustment of center of gravity via the oblong holes of the seat adapter as described below in chapter “One piece seat plate”.

4.2.1 Telescopic seat frame

i • 6 mm Allen key

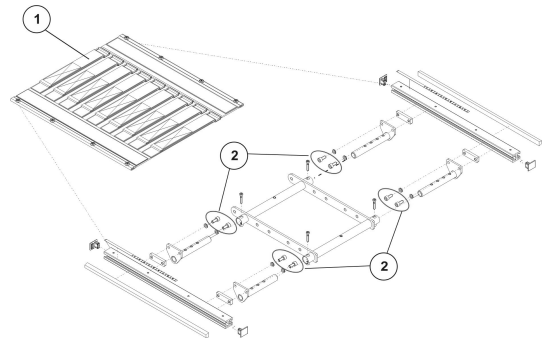

1. Remove seat plate or sling seat (1), see chapter “Adjusting seat width” in Modulite service manual.
2. Loosen Allen screws (2) in front and rear, left and right – DO NOT remove.
3. Shift position of seat.
4. Tighten screws.
5. Install seat plate or sling seat.

4.2.2 One-Piece Seat Plate

i • 6 mm Allen key

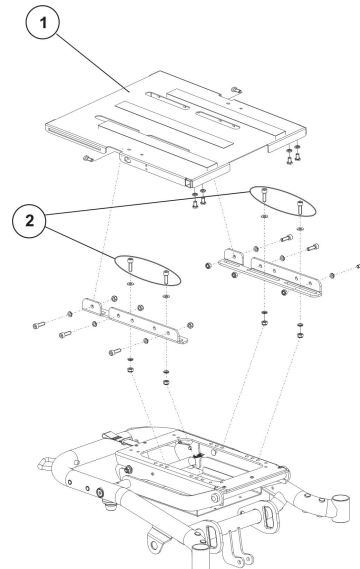

Fig. 4-1 This picture is an example.

1. Remove seat plate.
2. Loosen screws (2) left and right – DO NOT remove.
3. Shift position of seat frame.
4. Tighten screws.
5. Install seat plate.

4.3 Imperial to metric conversion chart

You can use this chart as an orientation to find the right tool size.



IMPERIAL	METRIC
inch	mm
5/64	1.9844
3/32	2.3813
7/64	2.7781
1/8	3.1750
9/64	3.5719

IMPERIAL	METRIC
inch	mm
5/32	3.9688
11/64	4.3656
3/16	4.7625
13/64	5.1594
7/32	5.5563
15/64	5.9531
1/4	6.3500
17/64	6.7469
9/32	7.1438
19/64	7.5406
5/16	7.9375
21/64	8.3344
11/32	8.7313
23/64	9.1281
3/8	9.5250
25/64	9.9219
13/32	10.3188
27/64	10.7156
7/16	11.1125
29/64	11.5094
15/32	11.9063
31/64	12.3031
1/2	12.7000
33/64	13.0969

IMPERIAL	METRIC
inch	mm
17/32	13.4938
35/64	13.8906
9/16	14.2875
37/64	14.6844
19/32	15.0813
39/64	15.4781
5/8	15.8750
41/64	16.2719
21/32	16.6688
43/64	17.0656
11/16	17.4625
45/64	17.8594
23/32	18.2563
47/64	18.6531
3/4	19.0500
49/64	19.4469
25/32	19.8438
51/64	20.2406
13/16	20.6375
53/64	21.0344
27/32	21.4313
55/64	21.8281
7/8	22.2250

5 Testing

5.1 Testing Motor

-  • Phillips screwdriver, size 2
-  • Digital multimeter with resistance measurement

1. Remove shroud that covers power module. See 6.9 *Shrouds, page 42*.
2. Unplug cable of motor (A) from power module.
3. Connect multimeter (B) to motor plug contacts (C) and (D) and measure resistance between contacts.

 A resistance of between 0.5 ohms and 5 ohms indicates a motor ready for operation. A resistance of between 15 ohms and infinity indicates a defective motor. High resistances are normally caused by bad connections or worn carbon brushes.

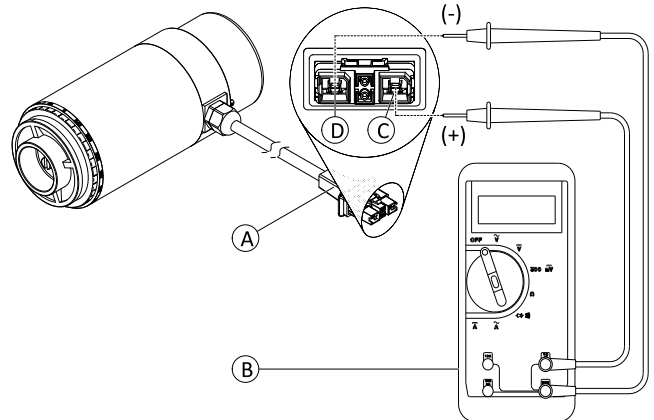



Fig. 5-1 DuraWatt motor serves as an example.

5.2 Testing Motor Brake

 This test should only be carried out on mobility device with conventional motor-gearbox units.





CAUTION!

Risk of damage to power module due to shorts in motor brake

- NEVER connect a shorted motor brake to an intact power module.
- Always replace shorted brakes immediately.

 A defective motor can damage the power module, but a defective power module cannot damage the motor.

-  • Phillips screwdriver, size 2
-  • Digital multimeter with resistance measurement

1. Remove shroud that covers power module. See 6.9 *Shrouds, page 42*.
2. Unplug cable of motor (A) from power module.
3. Connect multimeter (B) to motor plug contacts (E) and (F) and measure resistance between contacts.

 A resistance of between 40 ohms and 80 ohms indicates an intact brake. A resistance of 0 ohms or a very high resistance (mega-ohms or infinity) indicates a short-circuit, a bad connection or a defective brake.

4. If there is a defect, replace motor and send it to Invacare Service for inspection or repair.

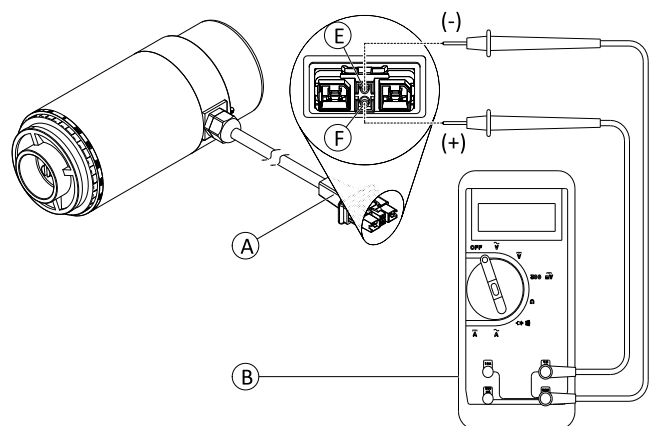



Fig. 5-2 DuraWatt motor serves as an example.

5.3 Rain test

- Check to ensure that the black battery terminal caps are secured in place, gaiter is not torn or cracked where water can enter and that all electrical connections are secure at all times.
- Do not use the mobility device if the gaiter is torn or cracked. If the gaiter becomes torn or cracked, replace immediately.

5.4 Field Load Test

Old batteries lose their ability to store and release power due to increased internal resistance. In this procedure, batteries are tested under load using a digital voltmeter to check battery charge level at the charger connector. The charger connector is located on the remote. When voltage at the output drops 1.0 volts under load (2.0 volts for a pair), replace the batteries.

 Read these instructions carefully and the manufacturer’s instructions on the digital voltmeter before proceeding.

-  • Voltmeter



WARNING!

– When performing the following steps, ensure your feet are clear from casters and wall, otherwise injury may result.

1. Switch electronics OFF on remote.
2. Make sure battery is fully charged. An extremely discharged battery will exhibit the same symptoms as a bad battery.
3. Remove footboard/legrests from mobility device.
4. Connect voltmeter leads to charger connector **A** on mobility device. Most digital voltmeters **B** are not affected by polarity. However, analog meters (meters with swinging needles) can be and should be used carefully.

 A good meter reading should be 25.5 VDC to 26.0 VDC with the chair in neutral.

5. Switch electronics ON on remote.
6. Ensure that your feet are clear from casters and wall.
7. Run mobility device in neutral for at least 2 minutes.
8. Sit in mobility device and place your feet against a door jam, workbench or other stationary object.
9. Carefully give forward command, trying to drive the mobility device through the stationary object. The load should draw between 30 amps to 40 amps from the batteries for 0.3 seconds.

 Performing this step puts a heavy load on the batteries as they try to push through the stationary object. If the wheels spin, have two individuals (one on each arm) apply as much downward pressure as possible on the arms of the mobility device.

10. Read meter while motors are straining to determine voltage under load.

 If the voltage drops more than 2.0 volts from a pair of fully charged batteries during the 0.3 seconds, they should be replaced regardless of the unloaded voltages.

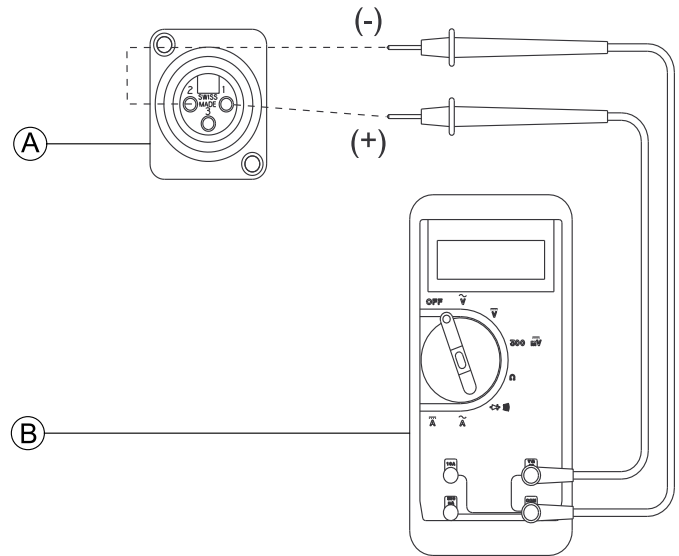

Fig. 5-3

5.5 Checking Battery Charge Level

The following “Dos” and “Don’ts” are provided for your convenience and safety.

DON'T	DO
Don't perform any installation or maintenance without first reading this manual.	Read and understand this manual and any service information that accompanies a battery and charger before operating the personal transporter.
Don't perform installation or maintenance of batteries in an area that could be damaged by battery spills.	Move the personal transporter to a work area before cleaning terminals, or opening battery box.
Don't make it a habit to discharge batteries to the lowest level.	Recharge as frequently as possible to maintain a high charge level and extend battery life.

DON'T	DO
Don't use chargers or batteries that are not appropriate for the chair.	Follow recommendations in this manual when selecting a battery or charger.
Don't put new batteries into service before charging.	Fully charge a new battery before using.
Don't tip or tilt batteries.	Use a carrying strap to remove, move or install a battery.
Don't tap on clamps and terminals with tools.	Push battery clamps on the terminals. Spread clamps wider if necessary.

6 Service

6.1 General Warning Information on Installation Work

CAUTION!

Risk of injury and damage to property, if the maximum speed reduction on a mobility device with a lifter does not function correctly
The mobility device's electronics must reduce the maximum possible speed as soon as the lifter is raised above 100 mm.

- Test the maximum speed reduction for correct function after any maintenance work or modifications to the mobility device.

6.2 Tightening torques

CAUTION!

Damage can be caused to the mobility device due to improperly tightened screws, nuts or plastic connections.

- Always tighten screws, nuts etc to the stated tightening torque.
- Only tighten screws or nuts which are not listed here fingertight.

The tightening torques stated in the following list are based on the thread diameter for the nuts and bolts for which no specific values have been determined. All values assume dry and de-greased threads.

Thread	Tightening torque in Nm $\pm 10\%$
M4	3 Nm
M5	6 Nm
M6	10 Nm
M8	25 Nm
M10	49 Nm
M12	80 Nm
M14	120 Nm
M16	180 Nm

6.3.2 Drive Fault Diagnosis

Problem	Other symptoms	Possible cause	Solution	Documentation
Mobility device will not start	The remote status display illuminates normally and shows an error code.	Drive motors disengaged	Engage drive motors.	See user manual.
	Remote status display does not illuminate	Batteries defective	Replace batteries.	See 6.11.4 Replacing Batteries (60 Ah / 73 Ah), page 48 and 6.11.6 Replacing Batteries / Battery Cables, page 49.
		Completely discharged battery	Pre-charge batteries.	See user manual.

UNC Thread	Tightening torque in Nm $\pm 10\%$
1/4"-20	11–7 Nm
5/16"-20	22–14 Nm
3/8"-16	41–25 Nm
7/16"-14	67–40 Nm
1/2"-13	100–60 Nm
9/16"-12	150–90 Nm
5/8"-11	210–130 Nm
3/4"-1	370–230 Nm
7/6"-9	600–370 Nm
1"-8	900–550 Nm

6.3 Troubleshooting

6.3.1 Operational Faults

Proceed as follows if you have any problems:

1. First assess the possible cause of the problem using the following table.
2. Check the remote status display. Evaluate the flash error code.
3. Carry out the necessary checks and repairs as recommended in the following table.

The various power modules can be fitted in connection with different remotes in the mobility device. Rectification of operational faults depends on the power module fitted. The power modules used are described in the corresponding controls manual.



The tables for rectification of operational faults listed in the following chapters are only an excerpt from the original manufacturer's manuals. You can obtain the original manuals from Invacare.

Problem	Other symptoms	Possible cause	Solution	Documentation
		Power supply to remote interrupted	Check main fuse.	See 6.11.7 <i>Checking and replacing main fuse, page 50</i> .
			Check cables between modules for loose connections or damage.	See 6.10.7 <i>Checking cable, page 46</i> .
		Remote defective	Replace remote.	See 6.10.1 <i>Replacing Power Module, page 43</i> .
	Remote status display flashing	Various causes	Assess error code.	See remote manual.
Mobility device judders in drive mode	None	Batteries defective (unstable voltage)	Replace batteries.	See 6.11.6 <i>Replacing Batteries / Battery Cables, page 49</i> and 6.11.4 <i>Replacing Batteries (60 Ah / 73 Ah), page 48</i> .
		Drive motor(s) defective	Replace motor(s).	See 6.7.2 <i>Replacing Motor/Gearbox Unit, page 29</i> .
			Replace carbon brushes.	See 6.7.5 <i>Replacing carbon brushes, page 31</i> .
Mobility device pulls to left or right	None	Drive motors running asymmetrically	Change programming to synchronise motors.	See programming manual.
	Tyre visibly dented	Not enough tyre pressure	Check tyre pressure, replace inner tube and/or valve if necessary.	
Error message does not disappear	None	Bad connections	Check all connecting cables.	See 6.10.7 <i>Checking cable, page 46</i> .
		Motor brake defective	Measure internal resistance of brakes, replace motor if defective.	See 5.2 <i>Testing Motor Brake, page 11</i> and 6.7.2 <i>Replacing Motor/Gearbox Unit, page 29</i> .
Motors stop and start again	None	Voltage decline	Stop driving and allow electronics to cool down.	
Motor runs but loses power	None	High motor load allows power module to lower voltage	Stop driving and allow electronics to cool down.	
Motors stop and do not start again	None	High motor load allows power module to lower voltage	Leave mobility device switched on and let power module operate. Charge batteries overnight with electronics turned on.	
	None	Fuse burnt out	Check cabling and replace fuse.	See 6.10.7 <i>Checking cable, page 46</i> and 6.11.7 <i>Checking and replacing main fuse, page 50</i> .

Problem	Other symptoms	Possible cause	Solution	Documentation
	None	Motor defective	Check carbon brushes and replace if necessary.	See 6.7.5 <i>Replacing carbon brushes, page 31.</i>
			Measure internal resistance of motor, replace motor if defective.	See 5.1 <i>Testing Motor, page 11</i> and 6.7.2 <i>Replacing Motor/Gearbox Unit, page 29.</i>
	None	Power module defective	Replace power module	See 6.10.1 <i>Replacing Power Module, page 43.</i>
Motors lose power while driving	None	Bad connections	Turn off electronics, wait 10 seconds, turn on electronics. Check all cabling.	See 6.10.7 <i>Checking cable, page 46.</i>
Motor judders or runs irregularly, or only one motor runs	None	Carbon brushes worn (only applies for motors without lifetime brushes)	Check carbon brushes and replace if necessary (only applies for motors without lifetime brushes).	See 6.7.5 <i>Replacing carbon brushes, page 31.</i>
		Clutch(es) defective	Replace clutch.	See 6.7.2 <i>Replacing Motor/Gearbox Unit, page 29.</i>
		Bearing defective	Replace motor.	See 6.7.2 <i>Replacing Motor/Gearbox Unit, page 29.</i>
		Collector defective	Measure internal resistance of motor, replace motor if defective.	See 5.1 <i>Testing Motor, page 11</i> and 6.7.2 <i>Replacing Motor/Gearbox Unit, page 29.</i>
Motors do not run	None	Bad connections	Check all cabling.	See 6.10.7 <i>Checking cable, page 46.</i>
		Fuse burnt out	Check cabling and replace fuse.	See 6.10.7 <i>Checking cable, page 46</i> and 6.11.7 <i>Checking and replacing main fuse, page 50.</i>
		Batteries defective	Replace batteries.	See 6.11.4 <i>Replacing Batteries (60 Ah / 73 Ah), page 48</i> and 6.11.6 <i>Replacing Batteries / Battery Cables, page 49.</i>
		Cabling to power module or remote defective	Check cabling.	See 6.10.7 <i>Checking cable, page 46.</i>
		Power module defective	Replace power module.	See 6.10.1 <i>Replacing Power Module, page 43.</i>
		Corroded contacts	Contacts defective	Check cabling, replace if necessary.
Motor makes clicking noise	None	Clutch(es) defective	Replace clutch.	See 6.7.2 <i>Replacing Motor/Gearbox Unit, page 29.</i>

Problem	Other symptoms	Possible cause	Solution	Documentation
		Bearing defective	Replace motor.	See 6.7.2 <i>Replacing Motor/Gearbox Unit</i> , page 29.
		Collector defective	Measure internal resistance of motor, replace motor if defective.	See 5.1 <i>Testing Motor</i> , page 11 and 6.7.2 <i>Replacing Motor/Gearbox Unit</i> , page 29
Scraping noise or motor blocked	None	Clutch(es) defective	Replace clutch.	See 6.7.4 <i>Replacing motor/gearbox clutch</i> , page 30.
		Bearing defective	Replace motor.	See 6.7.2 <i>Replacing Motor/Gearbox Unit</i> , page 29 and 6.7.4 <i>Replacing motor/gearbox clutch</i> , page 30.
		Gearbox defective	Replace gearbox.	See 6.7.2 <i>Replacing Motor/Gearbox Unit</i> , page 29 and 6.7.4 <i>Replacing motor/gearbox clutch</i> , page 30.
Gearbox makes clicking noise	None	Gearbox defective	Replace gearbox.	See 6.7.2 <i>Replacing Motor/Gearbox Unit</i> , page 29 and 6.7.4 <i>Replacing motor/gearbox clutch</i> , page 30.
		Drive wheel loose	Tighten drive wheel, secure bolts with thread locking adhesive if necessary.	See 6.7.2 <i>Replacing Motor/Gearbox Unit</i> , page 29.
Gearbox loses oil	None	Sealing ring on drive shaft defective	Replace gearbox if sealing ring defective.	See 6.7.2 <i>Replacing Motor/Gearbox Unit</i> , page 29 and 6.7.4 <i>Replacing motor/gearbox clutch</i> , page 30.
			Check carbon brushes for oil wetting, replace motor if brushes wet.	See 6.7.2 <i>Replacing Motor/Gearbox Unit</i> , page 29 and 6.7.4 <i>Replacing motor/gearbox clutch</i> , page 30 and 6.7.5 <i>Replacing carbon brushes</i> , page 31.
Irregular running	None	Drive shaft movable or bent	Check drive shaft, replace gearbox, if defective.	See 6.7.2 <i>Replacing Motor/Gearbox Unit</i> , page 29 and 6.7.4 <i>Replacing motor/gearbox clutch</i> , page 30.
Batteries not being charged	None	Fuse burnt out, cable defective	Check cabling and replace fuse.	See 6.10.7 <i>Checking cable</i> , page 46 and 6.11.7 <i>Checking and replacing main fuse</i> , page 50.

Problem	Other symptoms	Possible cause	Solution	Documentation
		Batteries defective	Replace batteries.	6.11.6 Replacing Batteries / Battery Cables, page 49 and 6.11.4 Replacing Batteries (60 Ah / 73 Ah), page 48.
	LEDs flashing on charger	Charger defective	Replace charger.	See charger user manual.
Short charging period	None	One of the batteries could be defective	Replace batteries.	See 6.11.6 Replacing Batteries / Battery Cables, page 49 and 6.11.4 Replacing Batteries (60 Ah / 73 Ah), page 48.
Mobility device runs too slowly	None	Remote defective	Replace remote.	See 6.10.1 Replacing Power Module, page 43.
		Batteries defective	Replace batteries.	See 6.11.6 Replacing Batteries / Battery Cables, page 49 and 6.11.4 Replacing Batteries (60 Ah / 73 Ah), page 48.

6.3.3 Charging device fault diagnosis

Symptom	Possible cause	Solution
No LEDs illuminating on battery charger	Charging device not connected to mains supply.	Ensure that the battery charger has been plugged in.
	No mains supply	Check the mains supply with a voltmeter.
	Defective mains supply cable.	Check the mains supply cable. Replace damaged cables or send the battery charger to Invacare Service for repair.
	LEDs are burnt out	Send the battery charger to Invacare Service for repair.
	An internal fuse might be burnt out.	Send the battery charger to Invacare Service for repair.
Batteries do not charge	Fuse on mobility device has burnt out.	Check mobility device fuses. See “Main fuse”.
	Battery charger not connected to mobility device.	Ensure that the battery charger has been connected to the mobility device.
	No mains supply	Check the mains supply with a voltmeter.
	Defective mains supply cable.	Check the mains supply cable. Replace damaged cables or send the battery charger to Invacare Service for repair.
	Battery charger could be defective.	Use a battery charger which you know is working properly to charge the batteries. Send the defective battery charger to Invacare Service for repair.
	Battery voltage is too low to operate mobility device.	Replace the batteries. See “Removing batteries”

6.4 Service Plan (Once a Year)



CAUTION!

Risk of injury and damage to property, if maximum speed reduction on wheelchair with lifter does not function correctly

The wheelchair's electronics must reduce the maximum possible speed as soon as the lifter is raised.

– Test the maximum speed reduction for correct function after any maintenance work or modifications to the wheelchair.

Component	Check	Remedy	Notes	✓
Posture belt	Damage to posture belt	Replace belt if damaged	See <i>Replacing Posture Belt</i> in service manual of seating system.	
	Belt lock function	Replace belt if damaged	See <i>Replacing Posture Belt</i> in service manual of seating system.	
Armrests	Damage to armrests	Replace cover if damaged		
	Armrest fixings	Tighten screws		
Clothing guard	Damage to clothing guard	Replace clothing guard, if damaged		
	Clothing guard fixings	Tighten screws		
Powered tilt	Tight fit of SL retainer clip	Replace SL retainer clip, if necessary		
Powered recline (if fitted)	Damage to backrest Seams Fixing Check cable Check function	Replace parts if damaged Tighten screws Replace cable or motor if necessary		
Frames (chassis) / battery mounting	Check fixings, welded seams and battery mounting	Tighten screws Replace components if necessary		
Stability Lock	Check gas cylinder	Repair or replace if damaged Replace gas cylinder every 2 years!	See 6.6.2 <i>Stability lock</i> , page 22.	
Dahl Docking station	Check screws	Tighten screws	See 6.14 <i>Mounting Dahl Docking System</i> , page 54.	
Wheel suspension and wheels	Check drive wheels for tight fit and side play	Adjust, replace wheel hubs	See 6.8.8 <i>Replacing Drive Wheel (5-Screw Installation)</i> , page 39 and 6.8.9 <i>Replacing drive wheel hub</i> , page 40.	
	Check castors for tight fit, float and side play	Replace wheels, castor forks or wheel bearings	See 6.8 <i>Wheels</i> , page 34.	
	Tyres	Repair or replace if damaged	See 6.8 <i>Wheels</i> , page 34.	
	Check suspension	Repair or replace if damaged	See 6.8 <i>Wheels</i> , page 34.	
	Check straight running	Replace wheels, castor forks or wheel bearings	See 6.8 <i>Wheels</i> , page 34.	

Component	Check	Remedy	Notes	✓
Drive units, clutch mechanism	Motors	Test motors	See 5.1 <i>Testing Motor</i> , page 11.	
	Check functions in drive and push modes Check clutch mechanism	Check carbon brushes, replace if necessary (not with lifetime brushes) Replace motor if necessary Tighten screws/nuts, adjust or replace if necessary	See 6.7 <i>Drive Components</i> , page 29.	
Brakes	Check motor brake	Test motor brake	See 5.1 <i>Testing Motor</i> , page 11.	
Legrests	Check welded seams, interlocking, screws, foot plates	Tighten, replace if necessary		
Power legrests (if fitted)	Check cable Check contacts Check functions	Replace cable if necessary		
Lighting (if fitted)	Check cable Check function	Replace lamp or cable if necessary	See 6.12 <i>Lighting unit</i> , page 50.	
Battery mounting	Check battery support and mounting belts for damage	Replace if necessary		
Batteries	Check batteries for damage	Replace batteries if necessary	See 6.11.4 <i>Replacing Batteries (60 Ah / 73 Ah)</i> , page 48, 6.11.6 <i>Replacing Batteries / Battery Cables</i> , page 49 and 6.11.2 <i>Handling Damaged Batteries Correctly</i> , page 47.	
	Check battery voltage	Charge batteries	See user manual.	
	Check contacts and terminals	Clean contacts and terminals	See safety information in 6.11.4 <i>Replacing Batteries (60 Ah / 73 Ah)</i> , page 48, 6.11.6 <i>Replacing Batteries / Battery Cables</i> , page 49 and 6.11.2 <i>Handling Damaged Batteries Correctly</i> , page 47.	
Remote / power module	Remote, status LED flashing	Evaluate error/flash code	See 6.3 <i>Troubleshooting</i> , page 14.	
	Fixings	Tighten fixings, replace if necessary		
	Cables and connecting plugs	Replace damaged cables and tighten connecting plugs, if necessary		
	Joystick function	Replace joystick knob if necessary		
		Replace remote if necessary		
Power supply	Replace damaged cables and tighten connecting plugs, if necessary			

Component	Check	Remedy	Notes	✓
Chair configuration	Check chair configuration version	Update software if newer version available	See LiNX service manual.	
Screws (every 6 months)	Check screws for tight fit	Tighten screws if necessary		

6.5 Overview mobility device

This overview applies for TDX SP2 mobility devices with Modulte Seat.

Underneath seat

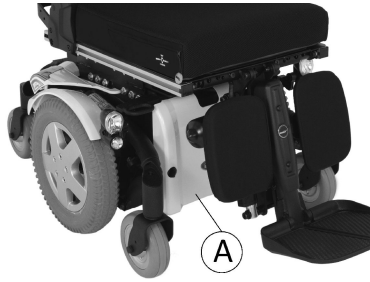

Batteries behind front shroud **A**
Fig. 6-1



Power module behind rear shroud **A**
Fig. 6-2

Actuator modules

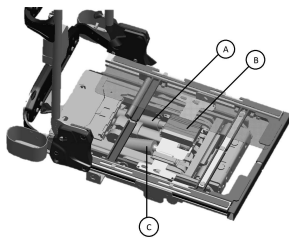

Tilt actuator (optional) **A**
Actuator module (optional) **B**
Lifter actuator (optional) **C**
Fig. 6-3

Lifter

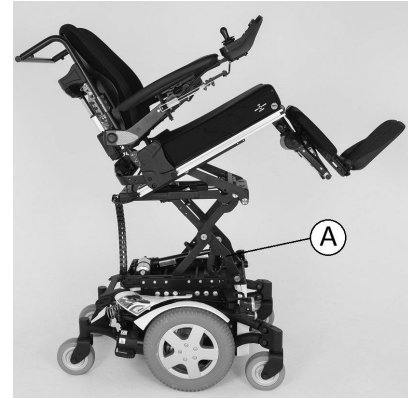

ACT with Lifter

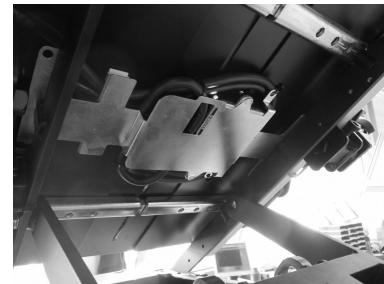

located under the seat.

Center mount powered legrests and tilt module



G-Trac® Sensor

The optional G-Trac-sensor is located behind the rear shroud.

6.6 Chassis

6.6.1 Overview of Components

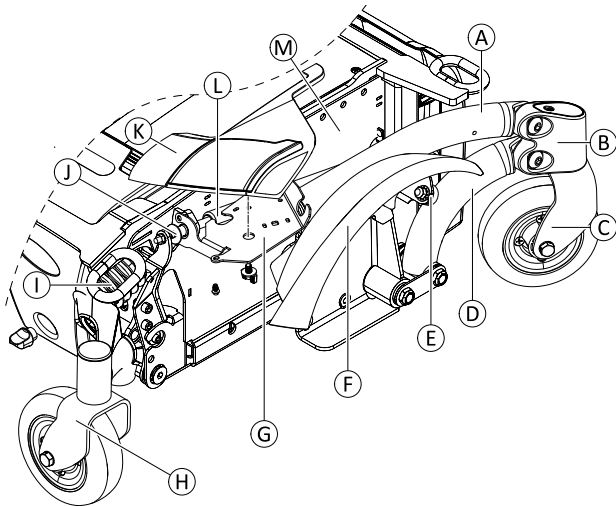

Fig. 6-4 Overview of the following described components and their location on the mobility device. For better view the propulsion unit and seat are not shown.

(A)	Top Walking Beam
(B)	Steering Head Front
(C)	Front Castor
(D)	Bottom Walking Beam
(E)	Rubber Stopper
(F)	Fender
(G)	Rear Light Bracket
(H)	Rear Castor
(I)	Rear Spring
(J)	Setting Screw
(K)	Rear Light
(L)	Gas Locking Cylinder
(M)	Battery Box

6.6.2 Stability lock

Replacing Gas Locking Cylinder



CAUTION!
Risk of strain from lifting heavy parts!
– Use proper lifting techniques.



CAUTION!
Risk of injury by uncontrolled movement of mobility device
– Switch power supply off (ON/OFF key).
– Engage drive.
– Before raising mobility device, secure wheels by blocking them with wedges.



- 3/16 in Allen key
- 5/16 in wrench with extension
- 3/4 in wrench
- 5/32 in Allen key
- 7/16 in socket wrench
- Phillips screwdriver, size 2
- Torque wrench 5 - 25 Nm (or similar)
- Two long wooden blocks, min. 14 x 14 x 30 cm
- Medium-strength thread locking adhesive (Loctite 242 or similar)



For better view the following illustrations does not show the seat system.

Removing Cylinder

1. Lift mobility device up on one side and place a 14 cm high wooden block under battery box so that wheels are off the ground and can rotate freely. Use proper lifting techniques.
2. Repeat same procedure on other side of mobility device.
- 3.

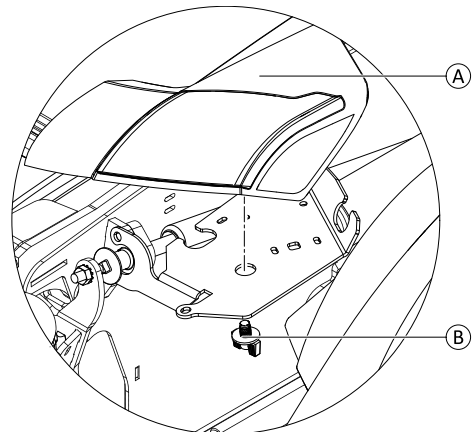



Fig. 6-5 Detail view of right rear light
Loosen and remove hand screw (B) of rear light (A).

4.
 -  When installing, make sure to replace cable ties.

If LED light is installed, unplug all plugs on rear side and remove rear light and cable ties.

- 5.

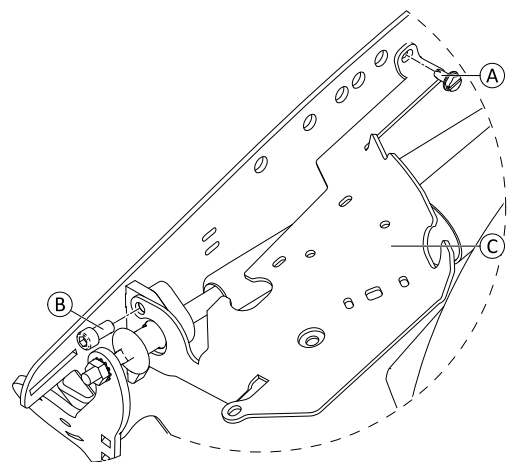

Fig. 6-6

Loosen and remove screws (A) and (B).

6. Remove rear light bracket (C).
7. Remove drive wheel. See 6.8.8 Replacing Drive Wheel (5-Screw Installation), page 39.
8. Remove fender. See 6.9.5 Replacing fender, page 43.

9. Remove batteries. See 6.11 Batteries, page 47.
- 10.

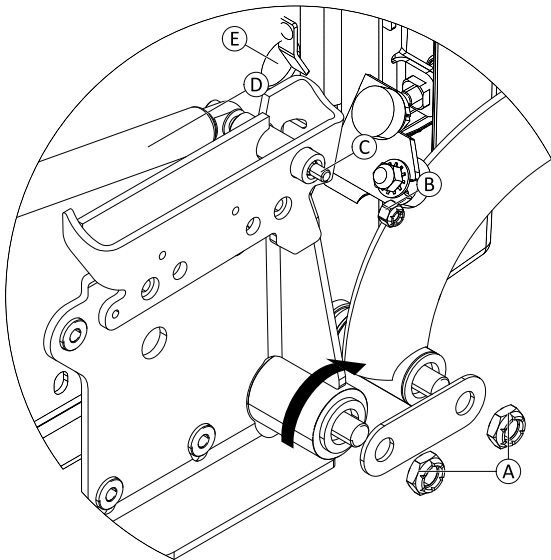



Fig. 6-7 Detail view of right walking beam assembly. For better view top walking beam, fender and motor/gearbox unit are not shown.

Loosen nuts **A** that fix lower walking beam to chassis.

11. Rotate top walking beam so that bolt **C** and drillhole **E** are in line.
12. Loosen and remove nut **B** on upper walking beam. Hold bolt **C** in place.
13. Push bolt **C** towards battery box so that gas cylinder **D** is separated from walking beam.
14. Push gas cylinder against battery box.
15. Raise rear axle so that gas cylinder is activated and then retract cylinder.
16. Push gas cylinder to the rear and pull it off battery box.

Installing Cylinder

 When installing nuts to lower and upper walking beam, use thread locking adhesive.

1. Install parts in reverse order.
2. Test all functions.

Replacing Setting Screw

-  • 1/4 in torque wrench 5 Nm -25 Nm (or similar)
- Two long wooden blocks, min. 14 x 14 x 30 cm
- Feeler gauge with 2.0 mm

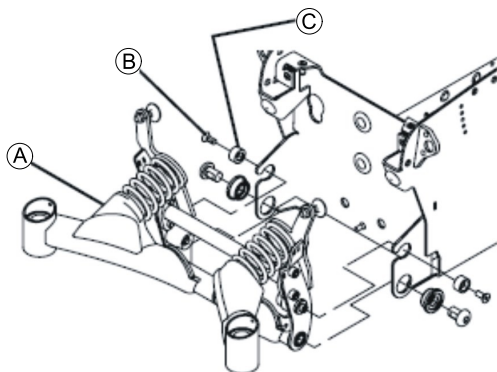



Fig. 6-8

 Invacare recommends always replacing both setting screws simultaneously to ensure that the mobility device works perfectly.

Removing Setting Screw

1. Lift the mobility device up on one side and place a 14 cm high wooden block under the battery case so that the wheels are off the ground and can rotate freely. Use proper lifting techniques.
2. Repeat same procedure on other side of mobility device.
3. Remove both anti-tip system protective caps. The protective caps on anti-tip system will either be held using a screw or a cable tie depending on the mobility device's date of manufacture.
- 4.

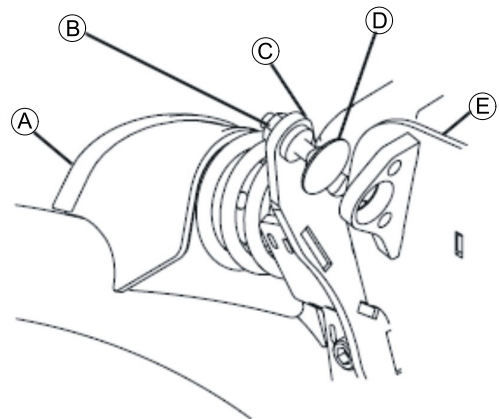



Fig. 6-9

Loosen two screws **B** and remove together with washers **C**.

5. Loosen and remove lock nut **B** of setting screw **D**.
6. Rotate setting screw **D** towards battery case until you can remove it from its holder **C**.

Installing Setting Screw

-  • 1/4 in torque wrench 5 Nm - 25 Nm (or similar)
- Feeler gauge with 2.0 mm

1. Screw new setting screw **D** into holder **C**.
- 2.

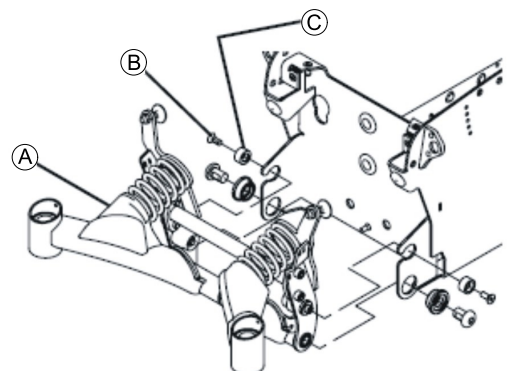

Fig. 6-10

Insert two screws **B** together with washers **C**.

3. Tighten screws.
4. Remove wooden block from under mobility device, so that all casters are in contact with floor.

5.



Fig. 6-11

Rotate setting screw © until there is a space of 2.0 mm (1) between it and gas cylinder ©.

6. Install lock nut ©. Tighten to 8 Nm.
7. Install two protective caps.

1. Remove both protective caps of stability lock system. They are held using a screw or a cable tie depending on the mobility device's date of manufacture.
2. Ensure that mobility device is contacting floor with all its wheels and casters.
3. Loosen and remove lock nut ©.
4. Rotate setting screw © until there is a space of 2.0 mm (1) between it and gas cylinder ©.
5. Install lock nut ©. Tighten to 8 Nm.
6. Repeat for other setting screw.
7. Install two protective caps.

Adjusting Setting Screw



- 1/4 in torque wrench 5 Nm - 25 Nm (or similar)
- Feeler gauge with 2.0 mm

6.6.3 Top Walking Beam

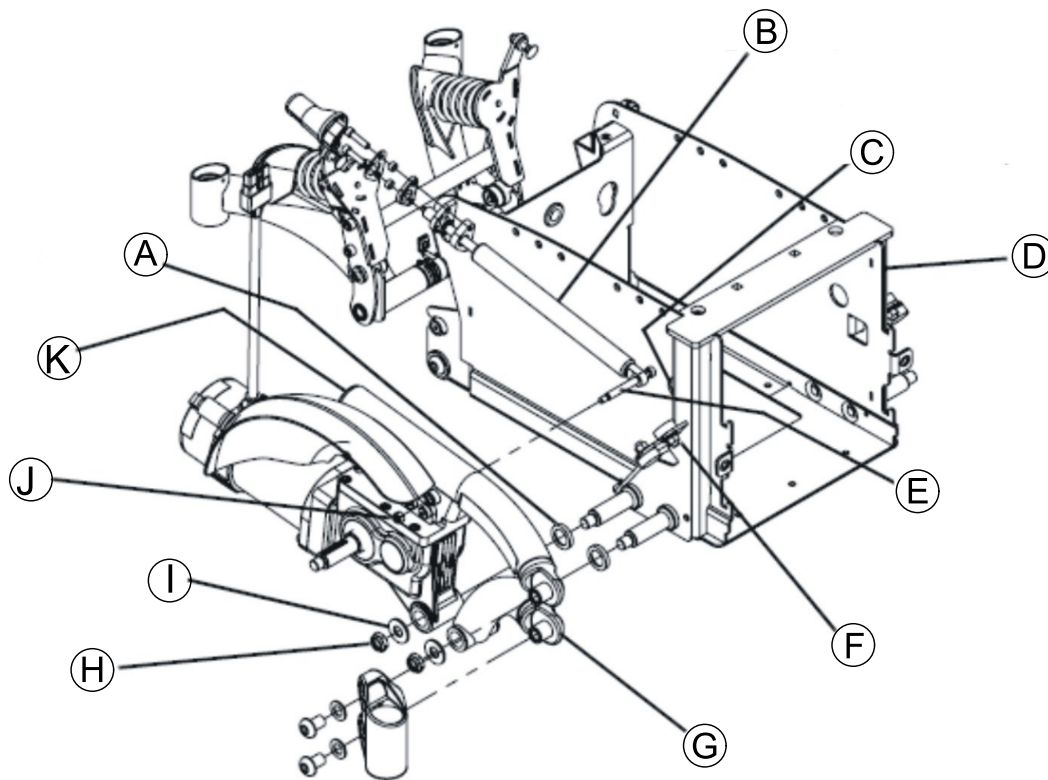

Fig. 6-12



- 5/16 in Allen key
- 5/8 in Allen key
- 7/8 in Allen key
- 1/4 in wrench
- 1/2 in wrench
- Phillips screwdriver, size 2
- Torque wrench 5 - 25 Nm (or similar)
- Two long wooden blocks, min. 14 x 14 x 30 cm

Removing Top Walking Beam

1. Remove batteries as described in 6.11.3 *Making Batteries Accessible*, page 48 and 6.11.4 *Replacing Batteries (60 Ah / 73 Ah)*, page 48/6.11.6 *Replacing Batteries / Battery Cables*, page 49
2. Ensure you note the cable routing carefully. If necessary, take photos with a digital camera.
3. Remove drive wheel as described in 6.8.8 *Replacing Drive Wheel (5-Screw Installation)*, page 39.
4. Remove front steering head as described in 6.6.5 *Steering head front*, page 25.
5. Remove rubber stopper as described in 6.6.10 *Replacing Rubber Stopper*, page 28.
6. Pull motor plug off power module.

Installing Top Walking Beam

1. Place washer (A) on battery case (D) rear axle.
2. Push top walking beam (K) including motor/gearbox unit onto axle.
3. Install washer (I) and nut (H).
4. Tighten nut (H) to 18 Nm.
5. Rotate nut (H) back by 1/4 turn.
6. Raise rear wheel suspension to free gas cylinder (B).
7. Position gas cylinder so that screw (E) is in line with opening (C) in battery case (D).
8. Rotate top walking beam (K) until drillhole for screw (E) is in line with opening (C) in battery case (D).
9. Push screw (E) through gas cylinder and top walking beam.
10. Install nut (I) on screw (E) and tighten to 8.5 Nm.

7. Note carefully how motor cable is routed.
8. If necessary, remove any existing cable ties which are fixing motor cable.
9. Rotate top walking beam (K) until Allen screw (E) is in line with opening (C) in battery case (D).
10. Remove nut (I), which secures screw (E).
11. Push screw (E) towards battery case until gas cylinder is free of top walking beam.
12. Fix gas cylinder in place with a cable tie or suitable adhesive tape.
13. Remove nut (H) and washer (I).
14. Remove top walking beam including motor/gearbox unit from axle.
15. Remove washer (A) from axle.

11. Install rubber stopper as described in 6.6.10 *Replacing Rubber Stopper*, page 28.
12. Install front steering head as described in 6.6.5 *Steering head front*, page 25.
13. Install batteries as described in 6.11.3 *Making Batteries Accessible*, page 48 and 6.11.4 *Replacing Batteries (60 Ah / 73 Ah)*, page 48/6.11.6 *Replacing Batteries / Battery Cables*, page 49 .
14. Install rear shroud as described in 6.9.2 *Replacing Rear Shroud (Without Operating Hour Counter)*, page 42.
15. Install front shroud as described in 6.9.1 *Removing front shroud*, page 42.
16. Install drive wheel as described 6.8.8 *Replacing Drive Wheel (5-Screw Installation)*, page 39.

6.6.4 Bottom Walking Beam



- 5/8 inch Allen key
- 5/16 inch Allen key
- Phillips screwdriver size 2
- 1/2 inch wrench
- Torque wrench 5 - 25 Nm (or similar)
- Two oblong wooden blocks (at least 14 x 14 x 30 cm)

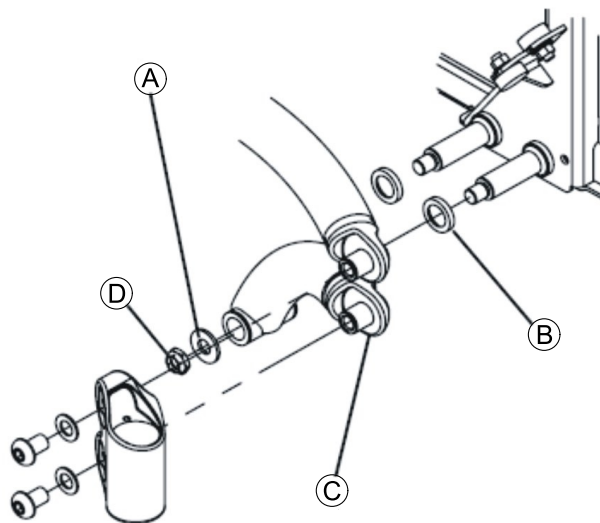

Fig. 6-13

Removing Bottom Walking Beam

1. Remove drive wheel as described in 6.8.8 *Replacing Drive Wheel (5-Screw Installation)*, page 39
2. Remove front steering head as described in 6.6.5 *Steering head front*, page 25.
3. Remove nut (D).
4. Remove washer (A).
5. Remove bottom walking beam (C) from axle.
6. Remove spacer (B) from axle.

Installing Bottom Walking Beam

1. Install parts in reverse order.
2. Tighten nuts (D) to 18 Nm.

6.6.5 Steering head front



- 5/16 in Allen key
- Torque wrench 5 - 25 Nm (or similar)

Removing steering head front

1.

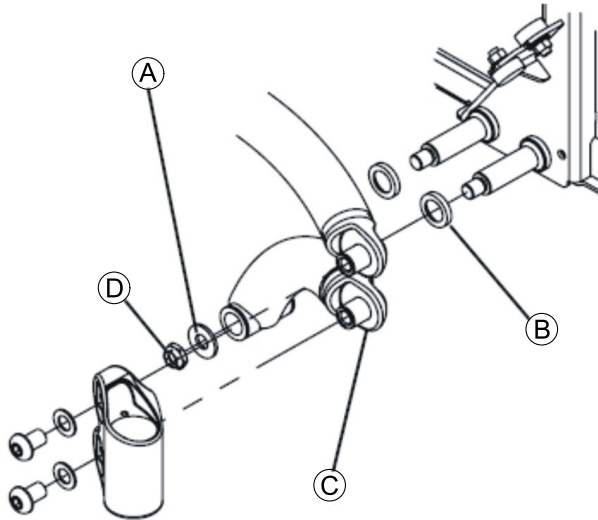

Fig. 6-14

Remove two Allen screws (A).

2. Remove two washers (B).
3. Remove steering head (E) from top walking beam (C) and bottom walking beam (D).

Installing steering head front

1. Install parts in reverse order.
2. Tighten screws according to following sequence:
 - Tighten all screws to 18 Nm.
 - Turn screws back by 1/8 turn.

6.6.6 Removing rear springs

 Invacare recommends always replacing both springs simultaneously to ensure that the mobility device works perfectly.



- 5/6" Allen key
- 5/32" Allen key
- Phillips screwdriver size 2
- Flat screwdriver
- 1/4" wrench
- 5/16" wrench
- Torque wrench 0 - 20 Nm (or similar)
- Oblique pliers
- Cable ties
- M8 washer
- Two long wooden blocks, min. 14 x 14 x 30 cm

1. Lift mobility device up on one side and place a 14 cm high wooden block under battery case so that wheels are off the ground and can rotate freely. Use proper lifting techniques.
2. Repeat same procedure on other side of mobility device.
3. Remove rear shroud as described in 6.9.2 *Replacing Rear Shroud (Without Operating Hour Counter)*, page 42.
4. Make sure you note cable routing carefully. If necessary, take photos with a digital camera.
5. Remove all cables and cable ties which are fixed to wheel suspension or which could get in the way during work.

6. Remove both protective caps of stability lock system. They are either held using a screw or a cable tie depending on the mobility device date of manufacture.

7.

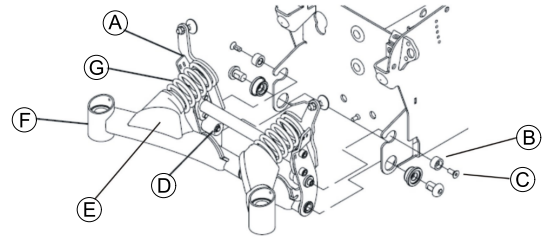

Make sure rear springs (G) are compressed:

- Block method
 - Raise suspension arms (F) and place wooden blocks underneath to remove stopper (D).
- Clamp method
 - Loosen both screws (C) and remove including spacer (B).
 - Make sure suspension arms (F) are lowered as much as possible.
 - Remove rubber caps (E).
 - Compress springs with joiner's clamp to remove stopper (D).

8. Loosen both nuts on stopper with wrench and remove nuts, washers and stopper. If necessary, use a flat screwdriver to loosen stopper.
9. Remove wooden blocks or joiner's clamps to release springs.
10. Remove springs.

6.6.7 Installing rear springs



Invacare recommends always replacing both springs simultaneously to make sure that the mobility device works perfectly.



CAUTION!

Risk of crushing

Mobility device is very heavy. Risk of injury to hands and feet.

- Use proper lifting techniques.

Risk of injury caused by uncontrolled movement of the mobility device

- Turn off power (ON/OFF key).
- Engage drive. Before propping up mobility device, secure wheels by blocking them with wedges.



- 5/6" Allen key
- 5/32" Allen key
- Phillips screwdriver size 2
- Flat screwdriver
- 1/4" wrench
- 5/16" wrench
- Torque wrench 0 - 20 Nm (or similar)
- Oblique pliers
- Cable ties
- M8 washer
- Two long wooden blocks, min. 14 x 14 x 30 cm

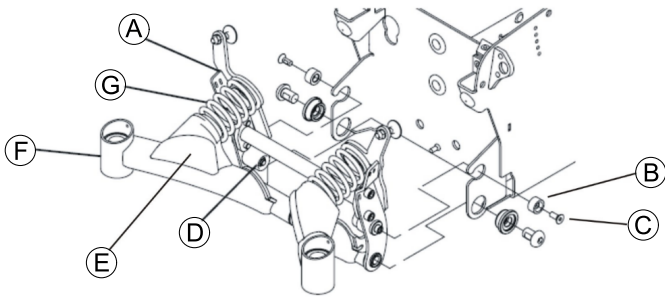

1. Put springs © into position between suspension arm ⑥ and stop ①.
2. Make sure rear springs are compressed:
 - Block method
 - Raise suspension arms and replace wooden blocks underneath them until springs are compressed.
 - Clamp method
 - Press springs together with joiner's clamp or similar suitable clamp until nylon spacer ② can be fitted into recesses provided in suspension ⑥.
 - Fit two screws © including spacer ②.
 - Tighten screws to 8.5 Nm.
3. Install two stoppers ④.
4. Fit washer and nuts to secure stoppers.
5. Tighten nuts to 8.5 Nm.
6. Remove wooden blocks or joiner's clamps carefully so that springs are released.
7. Reinsert all necessary plugs and fix cables with cable ties as previously. See also 6.10.8 *Cable routing*, page 46.
8. Install rear shroud as described in 6.9.2 *Replacing Rear Shroud (Without Operating Hour Counter)*, page 42.
9. Lift mobility device off wooden blocks.
10. Check all mobility device functions.
11. If necessary, carry out adjustments to setting screw on stability lock system as described in *Adjusting Setting Screw*, page 24.
12. Fit both protective caps of the stability lock system. They are held using a screw or a cable tie depending on mobility device's date of manufacture.

6.6.8 Replacing battery tray



- Phillips screwdriver size 2
- 5/8" Allen key
- 5/32" Allen key



TDX SP2 Low-Rider does not have a battery tray. Remove batteries manually.

Removing battery tray

1. Make batteries accessible as described in 6.11.3 *Making Batteries Accessible*, page 48.
2. Remove batteries as described in chapter 6.11.4 *Replacing Batteries (60 Ah / 73 Ah)*, page 48 / 6.11.6 *Replacing Batteries / Battery Cables*, page 49 / 6.10.2 *Replacing Tilt Actuator ("Fixed Pivot" Tilt)*, page 44.

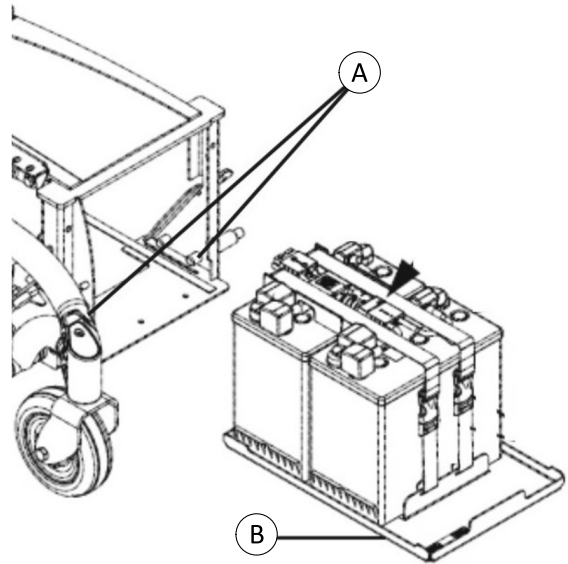

3. Remove two stop bolts ①.
4. Pull battery tray ② out of battery box.

Installing battery tray

1. Install parts in reverse order.

6.6.9 Replacing battery box



- 5/6" Allen key
- 5/32" Allen key
- Phillips screwdriver size 2
- Flat screwdriver
- 1/4" wrench
- 5/16" wrench
- Torque wrench 0 - 20 Nm (or similar)
- Torque wrench 5 - 25 Nm (or similar)
- Torque wrench 20 - 80 Nm (or similar)
- Oblique pliers
- Cable ties
- M8 washer
- Two long wooden blocks, min. 14 x 14 x 30 cm

Removing battery box

1. Remove seat including seat support as described in "Seating" and in Modulite service manual.
2. Remove shrouds as described in 6.9 *Shrouds*, page 42.
3. Remove batteries as described in 6.11.3 *Making Batteries Accessible*, page 48 and 6.11.4 *Replacing Batteries (60 Ah / 73 Ah)*, page 48 / 6.11.6 *Replacing Batteries / Battery Cables*, page 49.
4. Remove battery support as described 6.6.8 *Replacing battery tray*, page 27.
5. Remove headlights and rear lights depending on version (including holder) as described in 6.12 *Lighting unit*, page 50.
6. Remove power module as described in 6.10.1 *Replacing Power Module*, page 43. See corresponding service manual:
 - For LinX, see LiNX service manual.
 - For DX2, see revision 11 of TDX SP2 service manual.
7. Remove bottom walking beams as described in 6.6.4 *Bottom Walking Beam*, page 25.
8. Remove top walking beams as described in *Removing Top Walking Beam*, page 25.
9. Remove gas cylinder as described in *Replacing Gas Locking Cylinder*, page 22.
10. Remove rear wheel suspension as described in 6.8 *Wheels*, page 34.

11. Remove front and rear bulb holders depending on version as described in 6.12 *Lighting unit*, page 50.
12. Remove rubber stopper as described in 6.6.10 *Replacing Rubber Stopper*, page 28.
13. Remove battery box.

Installing battery box

1. Install rubber stopper as described in 6.6.10 *Replacing Rubber Stopper*, page 28.
2. Install front and rear lampholder depending on version as described in 6.12 *Lighting unit*, page 50.
3. Install rear wheel suspension as described in 6.8 *Wheels*, page 34.
4. Install gas cylinder as described in *Replacing Gas Locking Cylinder*, page 22.
5. Install top walking beams as described in *Installing Top Walking Beam*, page 25.
6. Install bottom walking beams as described in 6.6.4 *Bottom Walking Beam*, page 25.
7. Install power module as described in 6.10.1 *Replacing Power Module*, page 43.
8. Install battery support as described in 6.6.8 *Replacing battery tray*, page 27.
9. Install batteries in their correct location as described in 6.11.4 *Replacing Batteries (60 Ah / 73 Ah)*, page 48/6.11.6 *Replacing Batteries / Battery Cables*, page 49 and 6.11.3 *Making Batteries Accessible*, page 48.
10. Install shrouds as described in 6.9 *Shrouds*, page 42.
11. Install seat including seat support as described in 6.13 *Seating*, page 54 and Modulite service manual.
12. Adjust setting screw on anti-tip system as described in *Adjusting Setting Screw*, page 24.
13. To conclude, carry out an extensive driving and function test with mobility device.

6.6.10 Replacing Rubber Stopper

 Invacare recommends that you replace all rubber stoppers as soon as one needs replacing.

- 
- 5/16 inch wrench
 - 7/8 inch Allen key
 - Two oblong wooden blocks (at least 14 x 14 x 30 cm)
 - Torque wrench 5 - 25 Nm (or similar)

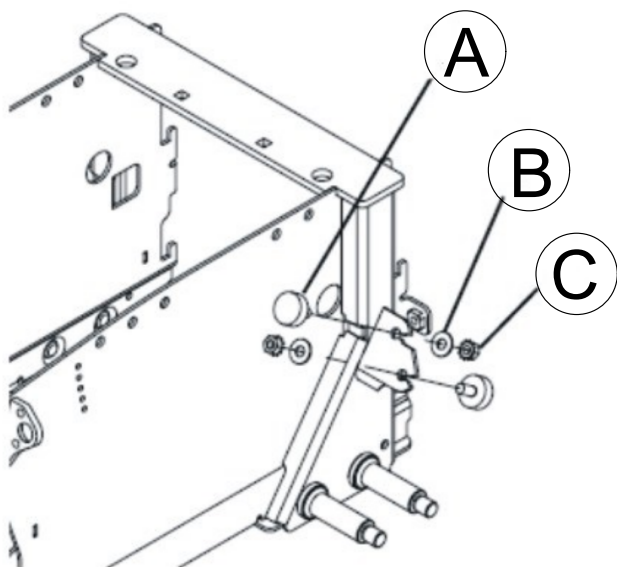

Fig. 6-15

Removing Rubber Stopper

1. Remove drive wheel as described in 6.8.8 *Replacing Drive Wheel (5-Screw Installation)*, page 39.
2. Loosen and remove nut **C**.
3. Remove washer **B**.
4. Remove rubber stopper **A**.

Installing Rubber Stopper

1. Install parts in reverse order.

6.6.11 Replacing Tie-Down Adapter (Low-Rider)

 The Low-Rider kit may not be used for retrofitting.

 **CAUTION!**
Risk of strain from lifting heavy parts!
– Use proper lifting techniques.

 **CAUTION!**
Risk of fire and burns if battery terminal is shorted
– Take great care to make sure that battery terminals are never shorted with tools or mechanical mobility device parts.
– Ensure that tilt module is equipped with a battery protection plate on its bottom side.

- 
- TX30 Torx key
 - 6 mm Allen key
 - 13 mm wrench
 - Medium-strength thread locking adhesive (Loctite 243 or similar)

Removing Adapter

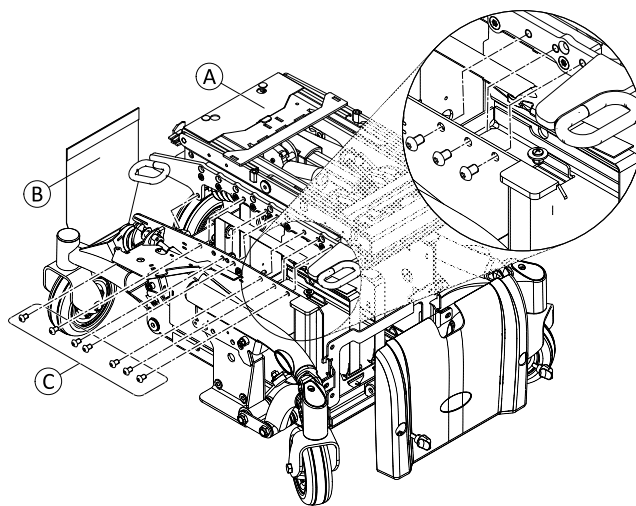

Fig. 6-16

1. Turn OFF electronics.
2. Remove rear and front shroud. See 6.9.2 *Replacing Rear Shroud (Without Operating Hour Counter)*, page 42 and 6.9.1 *Removing front shroud*, page 42.
3. Loosen and remove water protection flap **B**.
4. Unplug battery plug. See 6.11.3 *Making Batteries Accessible*, page 48.
5. Remove seat. See relevant topics in service manuals of corresponding seating system.
6. Loosen and remove screws **C** on both sides.
7. Lift off tie-down adapter assembly **A** from chassis.

Replacing Tie-Down Bracket / Tilt-Module

The seat can be set to two different seat heights. Adjust seat height at tie-down adapter according to following table:

403 mm	lower holes
420 mm	upper holes

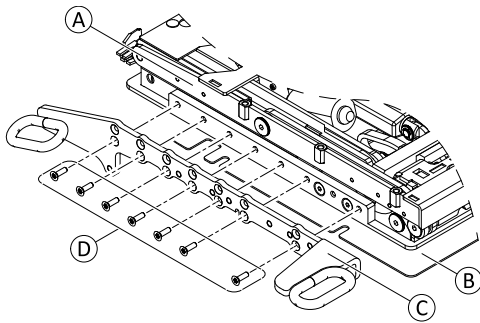

Fig. 6-17

1. Loosen and remove screws **D**.
2. Remove tie-down brackets **C** from **A**.
3. Replace defective parts.
4. Install parts in reverse order. Ensure that new tilt module is equipped with battery protection plate **B**.

Installing Adapter

1. Install parts in reverse order.
2. Plug in battery plug.
3. Test all functions.

6.7 Drive Components

6.7.1 Overview Motor/Gearbox Unit

Not all motor-gearbox combinations are available for all models. Contact your provider or check the spare parts catalogue.

The following mounting instructions are valid for all combinations.

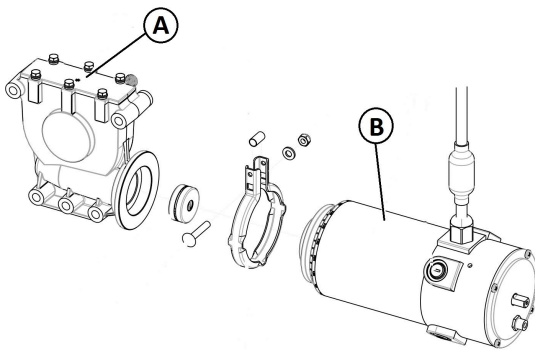



Fig. 6-18 Example of a motor/gearbox unit with SSD motor

 For description of old motors and components, see earlier revision of service manual.

6.7.2 Replacing Motor/Gearbox Unit



CAUTION!

Risk of crushing

The wheelchair is very heavy. Risk of injury to hands and feet.
– Use proper lifting techniques.

Risk of injury due to uncontrolled movement of the mobility device

- Turn off power (ON-/OFF key).
- Engage drive motors.
- Secure mobility device against rolling away by placing wedges under wheels.



CAUTION!

Risk of crushing

Motor gearbox unit is extremely heavy. Risk of injury to hands.
– Pay attention to heavy weight.



DuraWatt motors are maintenance-free, due to lifetime brushes.



- 6 mm Allen key
- 5/8 inch Allen key
- 7/8 inch Allen key
- 5/16 inch Allen key
- Phillips screwdriver size 2
- 13 mm socket wrench
- 1/2 inch socket wrench
- 1/4 inch socket wrench
- 5/16 inch socket wrench
- Torque wrench 5 - 25 Nm (or similar)
- Torque wrench 10 - 80 Nm (or similar)
- Two long wooden blocks, min. 14 x 14 x 30 cm

Removing Motor/Gearbox Unit

1. Remove rear battery box shroud, as described in *6.9.2 Replacing Rear Shroud (Without Operating Hour Counter)*, page 42.
2. Disconnect motor plug from power module.
3. Open cable ties so you can freely access motor cable.
4. Remove drive wheel, as described in *6.8.8 Replacing Drive Wheel (5-Screw Installation)*, page 39.
5. Remove wheel hub, as described in *6.8.9 Replacing drive wheel hub*, page 40.
- 6.

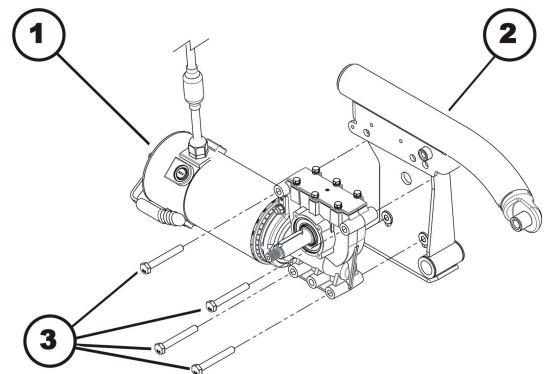

Fig. 6-19

7. Loosen four screws (3).
8. Remove screws.
9. Remove motor/gearbox unit (1) from walking beam (2).

Installing Motor/Gearbox Unit

1. Replace defective components.
2. Before installing a new motor/gearbox unit, make sure sealing ring is correctly mounted. The sealing ring securely attaches motor and gearbox. The ring must be installed such that self-locking nut is located on outside.
3. If the sealing ring is incorrectly installed, rotate it around as described in 6.7.3 *Replacing or rotating motor/gearbox unit sealing ring*, page 30.
4. Install motor/gearbox unit in reverse order.
5. Install all cable ties. Make sure to tie motor cable (A) to frame at 24 cm (B).

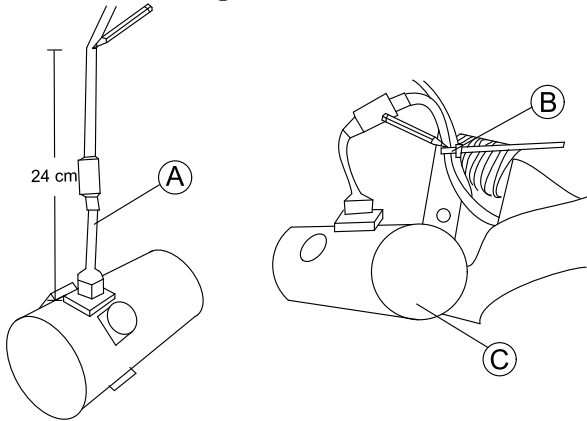

Fig. 6-20

6.

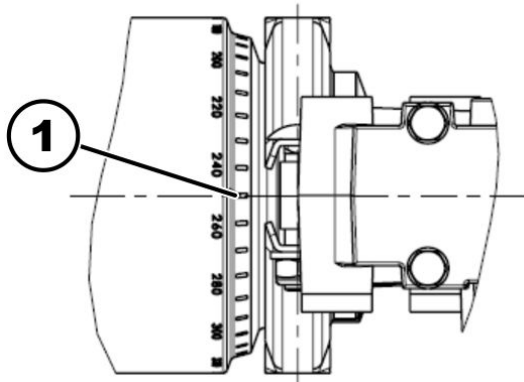

Fig. 6-21

Use scale to align motor to centre axis (1), 2-pole motors and 4-pole motors:

- Left: 0°
- Right: 0°

7. Make sure that motor cable cannot be pinched or bent, and that it is not exposed to chafing in any place.
8. If LiNX system is used, perform calibration process. See *Suggested programming procedure* in LiNX service manual.
9. Test all functions (trial run).

6.7.3 Replacing or rotating motor/gearbox unit sealing ring



CAUTION!
Risk of crushing

The motor / gearbox unit is very heavy. Risk of injury to hands.
– Pay attention to heavy weight.



- 6 mm Allen key
- 5/8" Allen key
- 7/8" Allen key
- 5/16" Allen key
- Phillips screwdriver size 2
- 10 mm socket wrench
- 1/2" socket wrench
- 1/4" socket wrench
- 5/16" socket wrench
- Torque wrench 0 - 25 Nm (or similar)
- Torque wrench 10 - 80 Nm (or similar)
- Two long wooden blocks, min. 14 x 14 x 30 cm

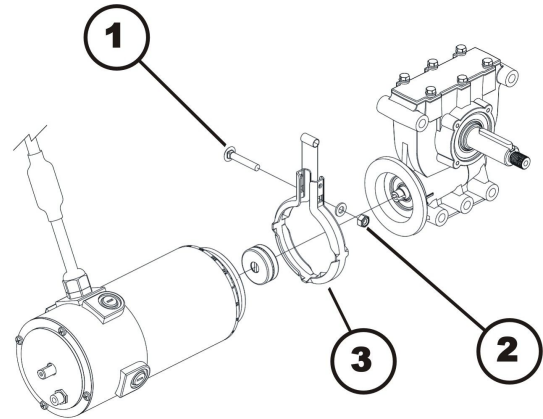

Removing sealing ring

1. Remove motor/gearbox unit, as described in chapter 8.14.2.
2. Use wrench to loosen and remove nut (2) including washer.
3. Remove screw (2), which secures sealing ring (3).
4. Carefully bend sealing ring apart and remove it.

Installing sealing ring

1. Install sealing ring so square hole for carriage screw is on inside of mobility device.
2. Insert carriage screw through sealing ring.
3. Install washer and self-locking nut.
4. Do not tighten nut completely, as motor orientation must be adjusted during installation.

6.7.4 Replacing motor/gearbox clutch



CAUTION!
Risk of crushing

Motor / gearbox unit is very heavy. Risk of injury to hands.
– Pay attention to heavy weight.



- 5/8" Allen key
- 7/8" Allen key
- 5/16" Allen key
- 6 mm Allen key
- Phillips screwdriver size 2
- 10 mm wrench
- 1/2" wrench
- 1/4" wrench
- 5/16" wrench
- Torque wrench 0 - 20 Nm (or similar)
- Torque wrench 5 - 25 Nm (or similar)
- Torque wrench 10 - 80 Nm (or similar)
- Two long wooden blocks, min. 14 x 14 x 30 cm

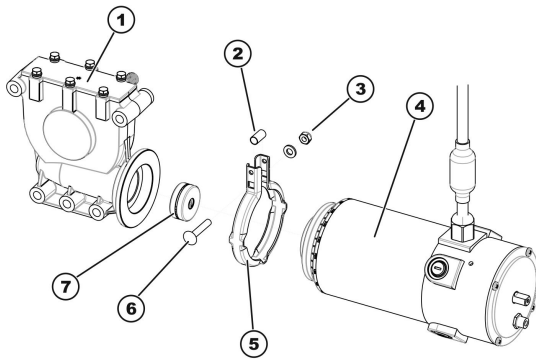

Removing motor/gearbox clutch

1. Removing motor/gearbox unit, as described in 6.7.2 *Replacing Motor/Gearbox Unit, page 29*.
2. Loosen and remove self-securing nut (3).
3. Remove carriage screw (6), which secures sealing ring (5).
4. Carefully bend sealing ring apart and remove it.
5. Pull motor (4) and gearbox unit (1) carefully apart.
6. Remove clutch individual parts (7).
7. Replace clutch, if necessary.

Installing motor/gearbox clutch

1. Install new clutch (7) on motor axle. Pay attention to position of groove.
2. Position locking ring (5) on motor (4) or gearbox (1).
3. Carefully insert motor into gearbox. Pay attention to position of groove in axle of gearbox. If necessary, rotate motor and gearbox to correct position.
4. Insert carriage bolt through locking ring. Do not forget spacer sleeve (2).
5. Install washer and self-locking nut.
6. Do not tighten self-locking nut completely, as motor orientation must be adjusted during installation.
7. Install motor/gearbox unit, as described in 6.7.2 *Replacing Motor/Gearbox Unit, page 29*.

6.7.5 Replacing carbon brushes

 Always replace all carbon brushes on both motors.

 DuraWatt motors are maintenance-free, due to lifetime brushes.



CAUTION! Risk of crushing

Mobility device is very heavy. Risk of Injury to hands and feet.
– Use proper lifting techniques.





- 5 mm Allen key
- 6 mm Allen key
- 10 mm socket wrench
- 19 mm socket wrench
- Screwdriver
- Two long wooden blocks, min. 14 x 14 x 30 cm

Removing carbon brushes

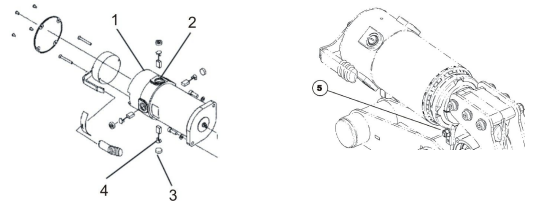
1. Turn off mobility device.
2. Remove drive wheels as described in 6.8.8 *Replacing Drive Wheel (5–Screw Installation), page 39*.



3. Disengage motor (1) by setting engaging lever to "Push".
 -  In case of SSD motor, loosen nut (5), then turn motor around so that you can access rear carbon brushes easier.
4. Remove all four plastic caps (3) with flat screwdriver.
5. Pull carbon brushes (4) a little out of brush holder. Note fixing position and location of carbon brushes.
 -  If carbon brushes were checked but not replaced, you must know their exact fitting position. Used carbon brushes need to be refitted exactly in the same position from which they were taken to guarantee optimum contact to collector.
6. Make a marking on motor and carbon brushes to guarantee correct installation.
7. Remove carbon brushes completely from mounting (2).
8. Test carbon brushes and springs for level of wear, broken components or discoloration.

Installing carbon brushes

1. Depending on condition of brushes and spring:
 - either re-insert brushes in exactly same position from which they were taken or
 - fit new brushes.
2. Replace plastic caps and tighten them.
3. Install top walking beams as described in *Installing Top Walking Beam, page 25*.
4. Install bottom walking beams as described in 6.6.4 *Bottom Walking Beam, page 25*.
5. Install drive wheels as described in 6.8.8 *Replacing Drive Wheel (5–Screw Installation), page 39*.



To guarantee maximum performance after replacement treat carbon brushes according to following procedure.



CAUTION! Risk of accidents

Risk of injury to workers, surroundings and mobility device.
– Do not leave mobility device unattended during following procedure.
– Make sure both drive wheels are off ground before calibrating.
– Secure area.

6. Lift mobility device up on one side and place a 14 cm high wooden block underneath it so that drive wheel is suspended freely. Use proper lifting techniques.
7. Repeat same procedure on other side of mobility device.
8. Allow motors to run in forward direction for an hour.

9. Allow motors to cool down for 30 minutes.
10. Allow motors to run in reverse direction for an hour.
11. Lift mobility device off wooden blocks.

6.7.6 Removing Rear Suspension



CAUTION!

Risk of crushing

The mobility device is very heavy. Risk of injury hazard to hands and feet.

- Use proper lifting techniques.

Risk of injury caused by uncontrolled movement of the mobility device

- Turn off power (ON/OFF key).
- Engage drive.
- Before raising mobility device, secure wheels by blocking them with wedges.



- 5/16 inch Allen key
- 5/32 inch Allen key
- Phillips screwdriver size 2
- Torque wrench 0 - 20 Nm (or similar)
- Torque wrench 20 - 80 Nm (or similar)
- Oblique pliers
- Tie wraps
- Two oblong wooden blocks (at least 14 x 14 x 30 cm)

1. Lift mobility device up on one side and place a 14 cm high wooden block under battery case so that wheels are off the ground and can rotate freely. Use proper lifting techniques.
2. Repeat same procedure on the other side of mobility device.
3. Remove rear shroud as described in 6.9.2 *Replacing Rear Shroud (Without Operating Hour Counter)*, page 42.
4. Make sure you note cable routing carefully. If necessary, take photos with a digital camera.
- 5.

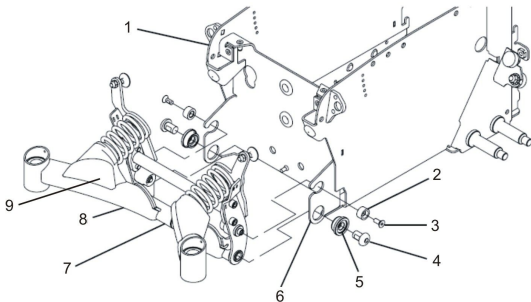

Remove all cables and tie wraps which are fixed to wheel suspension or which could get in the way during work.

6. Loosen two screws (3) and remove screws including nylon washer (2).
7. Loosen two screws (4) and remove screws including bushings (5). If only one of two screws can be removed, proceed as described in 6.7.7 *Removing rear suspension – alternative method*, page 32 as an alternative.
8. Take complete rear wheel suspension off.
9. Replace individual parts such as suspension arms (1) or pivot bar (4).
10. See 6.8.10 *Replacing Castor Wheel on Double-Sided Fork*, page 40 to install wheel suspension at a later time.

6.7.7 Removing rear suspension – alternative method



- More wooden blocks or joiner's clamps

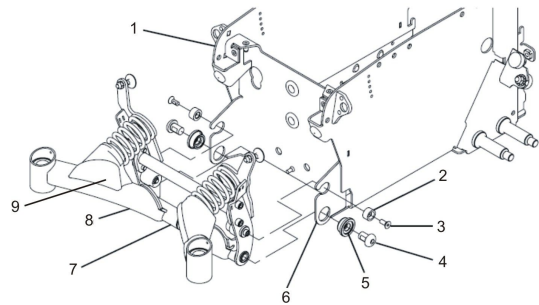

1. Carry out following steps if only one of the two screws (4) can be undone.
2. Make sure that rear springs are compressed:
 - Block method
 - Raise suspension arms and replace wooden blocks underneath them until springs are compressed.
 - Clamp method
 - Lower suspension arms downwards as far as possible.

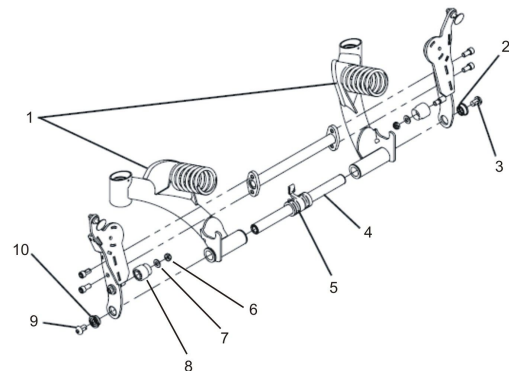

3. Remove rubber caps (9).
4. Press springs together with a joiner's clamp or similar clamp.
5. Remove pivot bar (4) by putting it sideways out of guides together with remaining bolt and socket.
6. See 6.7.9 *Refitting rear suspension – alternative method*, page 33 to replace wheel suspension at a later time.

6.7.8 Refitting rear suspension

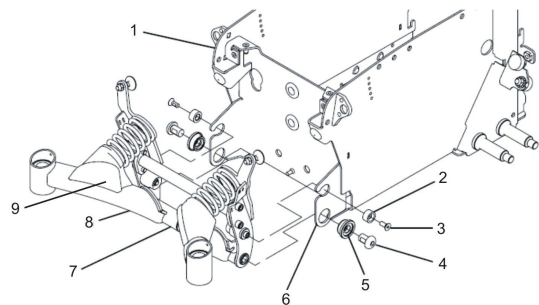

1. Position complete rear wheel suspension between two mounting points (6).
2. Fit two bushings (5) and two screws (4).

3. Tighten screws to 60 Nm.
4. Make sure that rear springs are compressed:
 - Block method
 - Lift suspension arm and place wooden blocks or similar underneath it until springs are pressed together and nylon spacer (2) can be fitted into recesses provided in suspension (6).
 - Clamp method
 - Remove rubber caps (9).
 - Press springs together with a joiner's clamp or similar suitable clamp until nylon spacer (2) can be fitted into recesses provided in suspension (6).
5. Fit two screws (3) including spacer (2).
6. Tighten screws to 8.5 Nm.
7. Replace two rubber caps (9) if necessary.
8. Install all necessary plugs and fix cables with cable ties as previously. See also 6.10.8 *Cable routing*, page 46.
9. Install rear shroud as described in 6.9.2 *Replacing Rear Shroud (Without Operating Hour Counter)*, page 42.
10. Lift mobility device off wooden blocks.
11. Check all mobility device functions.
12. If necessary, carry out adjustments to setting screw on stability lock system as described in *Adjusting Setting Screw*, page 24.

6.7.9 Refitting rear suspension – alternative method

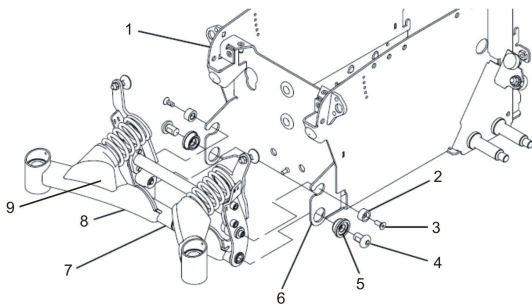

1. Position complete rear wheel suspension between two mounting points (6).

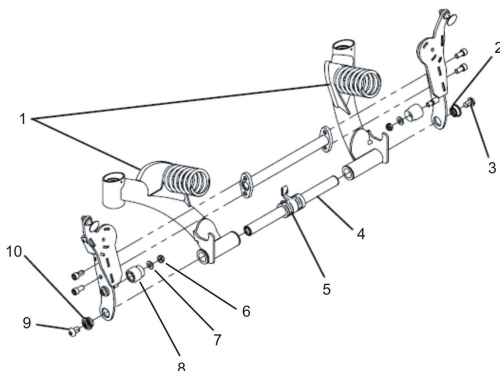

2. Position mounting (5) centrally between two suspension arms (1).
3. Push pivot bar (4) including remaining bolts and socket from side through guides, suspension arm bushes and mounting.

4. Install sockets and bolts you have removed.
5. Tighten bolts to 60 Nm.
- 6.

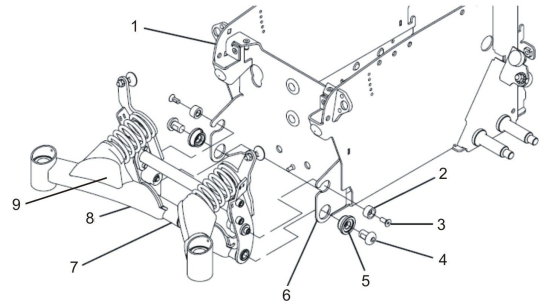

Make sure that rear springs are compressed:

- Block method
 - Lift suspension arm and place wooden blocks or similar underneath it until springs are pressed together and nylon spacer (2) can be fitted into recesses provided in suspension (6).
 - Clamp method
 - Remove rubber caps (9).
 - Press springs together with a joiner's clamp or similar suitable clamp until nylon spacer (2) can be fitted into recesses provided in suspension (6).
7. Fit two bolts (3) including nylon spacer (2).
 8. Tighten bolts to 8.5 Nm.
 9. Replace two rubber caps (9) if necessary.
 10. Install all plugs and fix cables with cable ties as previously. See also 6.10.8 *Cable routing*, page 46.
 11. Install rear shroud as described in 6.9.2 *Replacing Rear Shroud (Without Operating Hour Counter)*, page 42.
 12. Lift mobility device off wooden blocks.
 13. Test all mobility device functions.
 14. If necessary, carry out adjustments to setting screw on the stability lock system as described in *Adjusting Setting Screw*, page 24.

6.7.10 Replacing caster fork



- Size 2 Phillips screwdriver
- 5/8" socket wrench

Removing caster fork

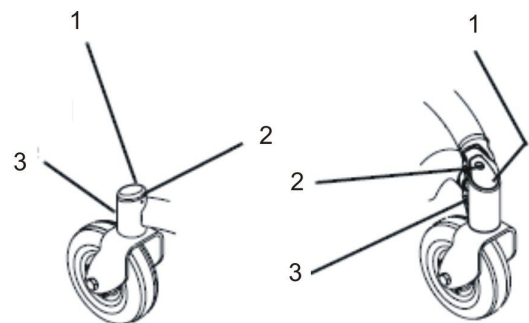

1. Loosen and remove Philips screw (2).
2. Take cap (1) off steering head (3).

3.

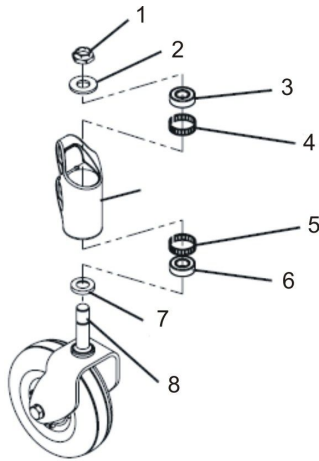

Loosen nut (1) with a 5/8" wrench.

4. Remove washer (2).
5. Remove caster fork (8) and spacer (7) downwards.
6. If necessary, remove ball-bearings (3) and (6) tolerance rings (4) and (5).

Installing caster fork

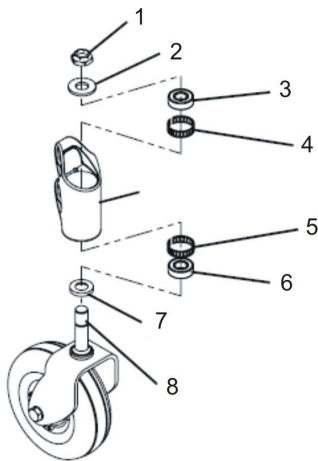

1. If you removed them, replace tolerance rings (4) and (5) and ball-bearings (3) and (6).
2. Place spacer (7) on caster fork (8).
3. Insert caster fork from underneath.
4. Fit washer (2) from above.
5. Fit nut (1) and tighten it loosely so that caster forks can just turn.
6. Adjust caster as described in 6.7.11 Adjusting caster fork, page 34.
- 7.

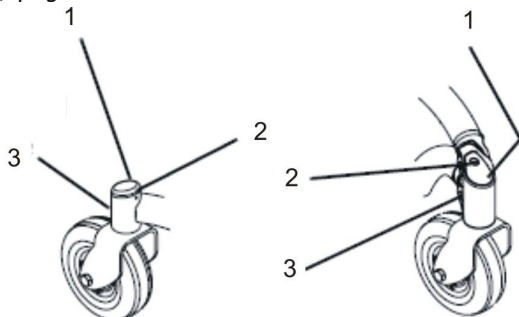

Place cover cap (1) on castor housing (3).

8. Tighten screw (2) finger-tight.

6.7.11 Adjusting caster fork



WARNING!

Risk of crushing

The mobility device is very heavy. Risk of injury to hands and feet.
– Use proper lifting techniques.



- Phillips screwdriver size 2
- 5/8" wrench



Front and rear casters are adjusted the same way. The following illustrations only show the front caster.

1.

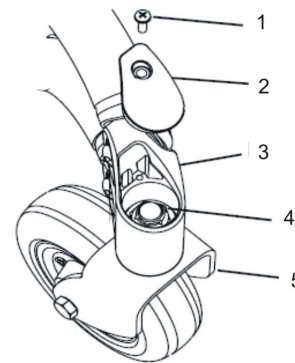

If necessary, remove screw (1) and cap (2).

2. Tilt mobility device to rear. Use proper lifting techniques.
3. Rotate caster forks (5) upwards.
4. Let go of caster forks so that they can swing downwards again.
5. Adjust nut (4) so that caster forks are not too loose but can still rotate freely. The caster forks should oscillate to the opposite side a maximum of once and then come to rest facing downwards.
6. Place mobility device on all four casters again.
7. Test mobility device's manoeuvrability.
8. Repeat adjustment steps if necessary until casters are correctly adjusted.
9. Replace cap (2) and tighten screw (1) finger-tight.

6.8 Wheels

6.8.1 Repair Instructions



Important information about maintenance work tools!

– Some maintenance work which is described in this manual and can be carried out by the user without problems require the correct tools for proper work. If you do not have the correct tool available we do not recommend that you try to carry out the relevant work. In this case, we urgently recommend that you contact an authorised specialist workshop.

The following are instructions on maintenance and repairs that can be performed by the user. For the specifications of spare parts please see *Technical Data*, or consult the service manual, available from Invacare (in this connection please see the addresses and phone numbers at the end of this user manual). In case you require assistance, please contact your Invacare dealer.



CAUTION!
Risk of damage or injury if the mobility device is accidentally set into motion during repairs
 – Switch the power off (ON/OFF Button).
 – Engage the motors.
 – Secure the mobility device against rolling away by placing wedges under the wheels.



CAUTION!
Risk of hands and feet being crushed by the weight of the wheelchair
 – Pay attention to your hands and feet.
 – Use the correct lifting techniques.

6.8.2 Tyre Pressure



CAUTION!
Risk of damage to rim and tyre when tyre pressure is exceeded
 – Observe recommended tyre pressure.

For recommended tyre pressure see inscription on tyre, rim, or contact Invacare. Compare table below for conversion.

psi	bar
22	1.5
23	1.6
25	1.7
26	1.8
28	1.9
29	2.0
30	2.1
32	2.2
33	2.3
35	2.4

psi	bar
36	2.5
38	2.6
39	2.7
41	2.8
42	2.9
44	3.0

6.8.3 Tyre Types

There are three different types of tyres or inner tubes, and specific points must be observed for the replacement of each type. The individual types of tyres can be easily distinguished:

- Pneumatic tyres have black valve caps.
- Puncture-protected tyres have red valve caps.
- Puncture-proof tyres have no valves.

There are five chapters about tyre repair and wheel replacement:

- *6.8.8 Replacing Drive Wheel (5-Screw Installation), page 39*
- *Replacing Drive Wheel (1-Bolt Installation)*
- *6.8.10 Replacing Castor Wheel on Double-Sided Fork, page 40*
- *6.8.11 Replacing Castor Wheels on Single-Sided Fork, page 41*
- *6.8.7 Replacing Tyres, page 38* deals with tube repair and replacing solid tyres.



Not all chapters are necessarily contained in this manual.



Specific tightening torques for wheels and rim halves are listed in *6.8.4 Specific Tightening Torques, page 35*.

6.8.4 Specific Tightening Torques

	Drive Wheels								
	10" x 3"	12 1/2" x 2 1/4"			14"				
Wheel Fixation	70 Nm	70 Nm	33 Nm	35 Nm	70 Nm	33 Nm	60 Nm	25 Nm	18 Nm
Rim Halves	25 Nm	25 Nm	10 Nm	25 Nm	25 Nm	10 Nm	25 Nm	25 Nm	18 Nm

	Castor Wheels									
	6"		8"				9"		10"	
Wheel Fixation	18 Nm	18 Nm	25 Nm	16 Nm	16 Nm	25 Nm	25 Nm	25 Nm	18 Nm	100 Nm
Rim Halves	10 Nm	25 Nm	5 Nm	—	—	—	25 Nm	5 Nm	25 Nm	25 Nm

6.8.5 Overview of Power Wheelchair Models and Wheel Types

- Not all wheel types are available for all power wheelchairs, see footnotes.
- The symbols indicate three tyre types:

pneumatic = black valve cap	puncture-protected = red valve cap	puncture-proof = no valve

Models	Drive wheels								
	10" x 3"	12 1/2" x 2 1/4"			14"				
	4-Spoke Rim (1-Bolt Installation)	3-Spoke Rim (1-Bolt Installation)	5-Spoke Rim (1-Bolt Installation)	5-Spoke Plastic Rim (1-Bolt Installation)	3-Spoke Rim (1-Bolt Installation)	5-Spoke Rim (1-Bolt Installation)*	5-Spoke Rim (5-Screw Installation)	5-Spoke Rim for True Track*	Solid Rim (5-screw installation)
TDX SP2									
Storm ⁴ Series									
Kite									
Bora									
Fox									
Stream									
Mirage									

Models	Drive wheels								
	10" x 3"	12 1/2" x 2 1/4"			14"				
	4-Spoke Rim (1-Bolt Installation)	3-Spoke Rim (1-Bolt Installation)	5-Spoke Rim (1-Bolt Installation)	5-Spoke Plastic Rim (1-Bolt Installation)	3-Spoke Rim (1-Bolt Installation)	5-Spoke Rim (1-Bolt Installation)*	5-Spoke Rim (5-Screw Installation)	5-Spoke Rim for True Track*	Solid Rim (5-screw installation)
Dragon			<input type="checkbox"/> <input checked="" type="checkbox"/>	<input type="checkbox"/>					
Pronto M41	<input checked="" type="checkbox"/>								
AVIVA RX									<input type="checkbox"/> <input checked="" type="checkbox"/> <input checked="" type="checkbox"/>

* For wheelchair-specific mounting instruction, see respective manual.

Models	Castor Wheels									
	6"	8"				9"			10"	
	Single-Sided/Double-Sided Fork	Double-Sided Fork				Single-Sided/Double-Sided Fork	Double-Sided Fork	Single-Sided/Double-Sided Fork	Double-Sided Fork	Single-Sided Fork
TDX SP2	<input checked="" type="checkbox"/>									
Storm ⁴ Series									<input type="checkbox"/> <input checked="" type="checkbox"/> <input checked="" type="checkbox"/>	<input type="checkbox"/> <input checked="" type="checkbox"/> <input checked="" type="checkbox"/>
Kite						<input checked="" type="checkbox"/> <input checked="" type="checkbox"/>			<input type="checkbox"/> <input checked="" type="checkbox"/> <input checked="" type="checkbox"/>	<input type="checkbox"/> <input checked="" type="checkbox"/> <input checked="" type="checkbox"/>
Bora		<input checked="" type="checkbox"/>		<input type="checkbox"/> <input checked="" type="checkbox"/>	<input checked="" type="checkbox"/>	<input type="checkbox"/> <input checked="" type="checkbox"/>				
Fox		<input checked="" type="checkbox"/>	<input checked="" type="checkbox"/>							
Stream						<input checked="" type="checkbox"/>				
Mirage		<input checked="" type="checkbox"/>	<input type="checkbox"/> <input checked="" type="checkbox"/>		<input checked="" type="checkbox"/>					
Dragon						<input checked="" type="checkbox"/>				

Models	Castor Wheels									
	6"		8"				9"		10"	
	Single-Sided/ Double-Sided Fork	Double-Sided Fork				Single-Sided/ Double-Sided Fork	Double-Sided Fork	Single-Sided/ Double-Sided Fork	Double-Sided Fork	Single-Sided Fork
Pronto M41	■									
AVIV-A RX						■		□ ■ ■		

* For wheelchair-specific mounting instruction, see respective manual.

6.8.6 Replacing rim inserts in drive wheels

- Slotted screwdriver

Removing rim insert

1. Insert tip of screwdriver between rim and rim insert.
2. Remove rim insert.

Installing rim insert

1. Hold insert over rim.
- 2.

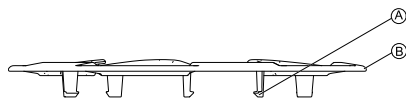

Carefully push to fasten rim insert, until foot of rim insert **A** snaps and rim insert **B** clings to rim.

6.8.7 Replacing Tyres

Repairing Pneumatic and Puncture-Protected Tyres

- 6 mm Allen key
- Tightening kit
- Oblong wooden block (at least 12 x 12 x 30 cm) for propping up mobility device
- Repair kit for tyre repair or a new inner tube
- Talcum powder
- Tyre pump or compressor



WARNING! Risk of Injury

If tyre with one or more damaged rim threads is inflated, rim could burst and cause serious injury.

- Do not inflate tyre if one or more rim threads are damaged.
- Immediately replace rim with damaged threads.



WARNING! Risk of Explosion

There is considerable pressure in the tyre. Risk of injury. Parts can be thrown out and injure you if you do not secure rim halves.

- Secure rim halves with joiner's clamps.



Risk of Damage to Rim Threads

Incorrectly tightened screws can cause damage to rim threads.

- Tighten rim screws with prescribed tightening torque.

1. Remove wheel as described in respective chapter in this manual.



CAUTION! Risk of Damage by Gel When Repairing Puncture-Protected Tyres With Red Valve Caps

Valve can become blocked by the puncture protection gel and get unusable.

- During following work you should always hold up valve so that puncture protection gel cannot enter valve.

2. Remove valve cap.
3. Let air escape completely out of tyre by firmly pressing in pin in the centre of valve.



CAUTION! Risk of Explosion

The wheel explodes if air pressure has not been released from wheel before wheel rim is removed.

- Always let all air out of tyre before removing rim.

4.

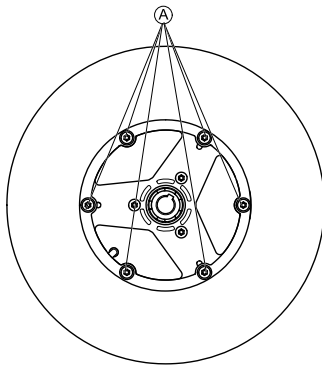

Fig. 6-22 This picture is an example.

Remove screws **A** on inside of wheel.

5. Remove rim halves from wheel.
6. Remove inner tube from tyre.
7. Repair inner tube and re-fit it, or replace it with a new one.

i If old inner tube has been repaired and is to be used again, and became wet during repair, it is easier to replace it if it is lightly dusted with talcum powder beforehand.

8. Install tyre in reverse order.
9. Apply rim halves to wheel.
10. Inflate tyre a little.
11. Place screws in wheel rim and tighten screws with prescribed torque. Make sure that inner tube is not clamped between wheel rim halves.
12. Make sure that tyre is contacting wheel rim directly.
13. Inflate tyre to prescribed pressure.
14. Make sure that tyre is still closely contacting wheel rim.
15. Screw valve cap on.
16. Install wheels according to instruction. See respective chapter.

Repairing Solid Tyre

- 6 mm Allen key
- 3 joiner's clamps with plastic caps

! **Risk of Damage to Rim Threads**
 Incorrectly tightened screws can cause damage to rim threads.
 – Tighten rim screws with prescribed tightening torque.

1. Remove wheel as described in respective chapter in this manual.
2. Secure rim halves against unexpected discharge with three joiner's clamps. When doing so, make sure that you do not scratch rims.
- 3.

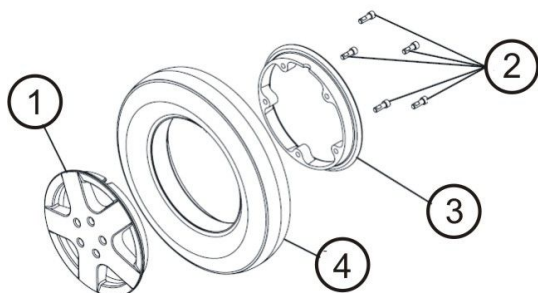

Fig. 6-23

Loosen and remove screws **(2)** on inside of wheel.

4. Loosen joiner's clamps carefully and alternately until you can remove rim halves without risk.
5. Remove inner **(3)** and outer **(1)** half of rim from tyre **(4)**.
6. Replace any defective or worn parts.
7. Install tyre in reverse order.
8. When fitting rim halves together, make sure that drill holes and threads for screws are placed exactly on top of each other.
9. Place joiner's clamps in position.
10. Tighten joiner's clamps alternately in small stages until rim halves are precisely aligned.
11. Install and tighten screws.
12. Remove joiner's clamps.
13. Install wheel as described in respective chapter in this manual.

6.8.8 Replacing Drive Wheel (5-Screw Installation)

This chapter deals with drive wheels that are installed with four or five screws.

! **CAUTION!**
Risk of Crushing to Hands and Feet by Weight of Mobility Device
 – Pay attention to hand and feet.
 – Use proper lifting techniques.

! **CAUTION!**
Risk of Uncontrolled Movement of Mobility Device
 – Turn off power supply (ON/OFF key).
 – Engage drive.
 – Before raising mobility device, secure wheels by blocking them with wedges.
 – Prevent the mobility device tipping by propping it up on a wooden block which is long and wide enough under the battery case. If the wooden block is too short or too high, the mobility device can still tip.

- 6 mm Allen key
- 13 mm wrench
- Torque wrench
- Oblong wooden block (at least 12 x 12 x 30 cm) for propping up mobility device

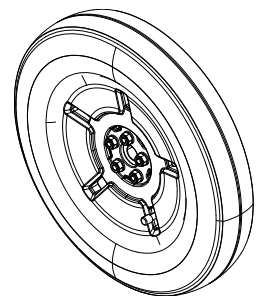

- Torx wrench with TX 40 bit
- Torque wrench
- Mounting kit
- Oblong wooden block (at least 12 x 12 x 30 cm) for propping up mobility device

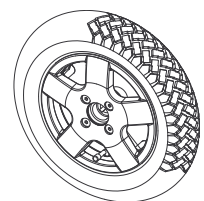



- 6 mm Allen key
- Torque wrench
- Oblong wooden block (at least 12 x 12 x 30 cm) for propping up mobility device
- Medium-strength thread locking adhesive (Loctite 243 or similar)



When removing, take care of small parts such as screws and washers. Put all small parts down so that they can be installed in correct sequence.

1. Remove legrests.
2. Place wooden block under frame to prevent mobility device from rolling away.
3. Loosen and remove screws which secure wheel.
4. Remove wheel from hub.
- 5.



CAUTION!

Risk of Injury if Wheels Come Off

If drive wheels are insufficiently tightened during assembly, they can come off during driving.

- Always use new screws with undamaged coating.
- Tighten screws to prescribed torque when mounting drive wheels.

Install parts in reverse order.

6. When installing wheel, pay attention to correct direction of rotation.

6.8.9 Replacing drive wheel hub



- 19 mm wrench

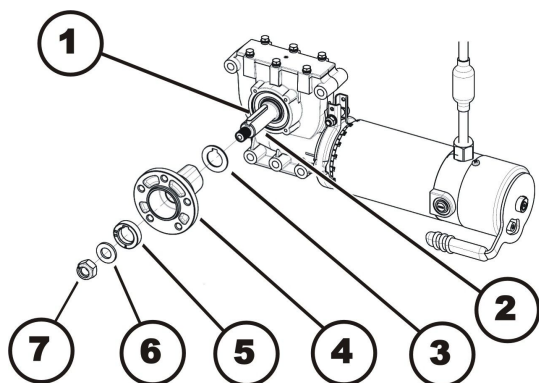

Removing drive wheel hub

1. Loosen and remove nut (7).
2. Remove washer (6).
3. Remove distance ring (5).
4. Remove wheel hub (4) from axle (2).
5. Remove shim rings (3).
6. Remove feather key (1) from axle.

Installing drive wheel hub

1. Install drive wheel hub parts in reverse order.
2. Use thin film of lubricant to easier install wheel hub on axle.
3. Tighten nuts (4) to 60 Nm.

6.8.10 Replacing Castor Wheel on Double-Sided Fork



- 5 mm Allen key
- 13 mm wrench
- Oblong wooden block (at least 14 x 14 x 30 cm)



- 13 mm wrench (2x)
- Oblong wooden block (at least 14 x 14 x 30 cm)



- 6 mm Allen key
- 13 mm wrench
- Oblong wooden block (at least 14 x 14 x 30 cm)

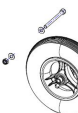

- 6 mm Allen key
- 13 mm wrench
- Oblong wooden block (at least 14 x 14 x 30 cm)



- 5 mm Allen key
- Oblong wooden block (at least 14 x 14 x 30 cm)



- 5 mm Allen key
- 13 mm wrench
- Oblong wooden block (at least 14 x 14 x 30 cm)



Removing Wheel

1. Place wooden block underneath mobility device and prop up mobility device.
2. Remove end-caps from bolt and nut (if applicable).

3.

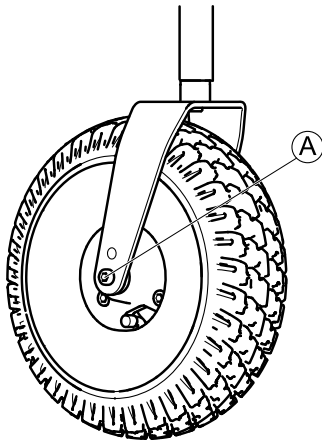

Fig. 6-24

Remove nut from bolt (A).

4. Remove bolt and wheel from fork.

Installing Wheel

1. Install parts in reverse order.
2. When installing wheel, pay attention to correct direction of rotation.
3. Tighten nut to prescribed torque. See 6.8.4 *Specific Tightening Torques*, page 35.

Replacing Castor Wheel (Aviva RX and Storm⁴ Max)



- 5 mm Allen key (up to August 2016)
- TX40 Torx key (starting August 2016)
- Oblong wooden block (at least 14 x 14 x 30 cm)

Removing Wheel

1. Loosen and remove bolts (A).
- 2.

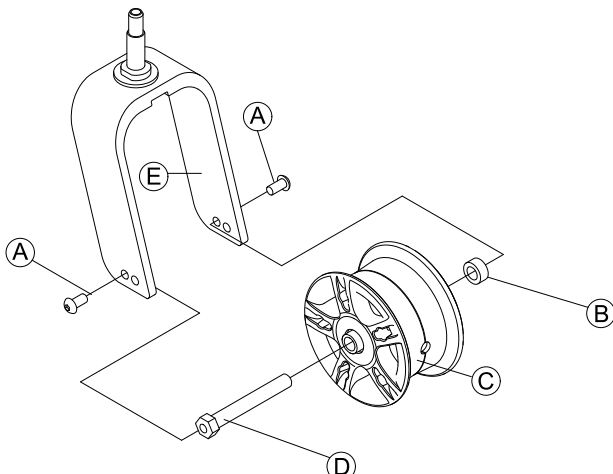

Fig. 6-25

Pull wheel (C) including axle (D) and bushing (B) out of fork (E).

Installing Wheel



CAUTION!

Risk of injury from wheels coming loose

- If wheels are insufficiently secured during mounting, it can come loose when driving.
- When mounting wheels tighten bolts with prescribed torque.
 - Secure all bolts using a suitable blocker.
 - Never use normal nuts instead of self-locking nuts.
 - Always use new nuts and bolts with an undamaged coating.

1. Install parts in reverse order. Pay attention to correct direction of rotation when installing wheels.
2. Test all functions.

Replacing Castor Wheel (6 inch wheel)



- 2 x 7/16 inch wrench
- Oblong wooden block (at least 14 x 14 x 30 cm)



Removing Wheel

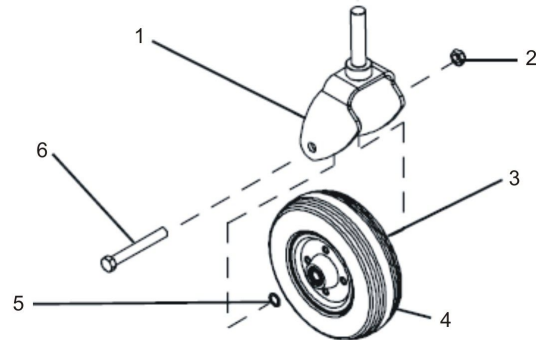

Fig. 6-26

1. Loosen nut (2).
2. Remove screw (6).
3. Remove two washers (3) and (5).
4. Remove wheel (4).
5. Replace any defective parts.

Installing Wheel

1. Install parts in reverse order.
2. When installing wheel, pay attention to correct direction of rotation.
3. Tighten nut to prescribed torque. See 6.8.4 *Specific Tightening Torques*, page 35.

6.8.11 Replacing Castor Wheels on Single-Sided Fork



- 24 mm wrench
- Oblong wooden block (at least 14 x 14 x 30 cm)



Removing Wheel

1. Place wooden block underneath mobility device and prop up mobility device.
2. Remove end-caps from bolt and nut (if applicable).
3. Remove nut and washer from bolt.
4. Remove bolt and wheel from fork.

Installing Wheel

1. Install parts in reverse order.
2. When installing wheel, pay attention to correct direction of rotation.
3. Tighten nut to prescribed torque. See 6.8.4 *Specific Tightening Torques*, page 35.

Replacing Castor Wheel (AVIVA RX, TDX SP2)



- TX30 Torx key (TDX SP2)
- TX40 Torx key (AVIVA RX)
- Oblong wooden block (at least 14 x 14 x 30 cm)



Removing Wheel

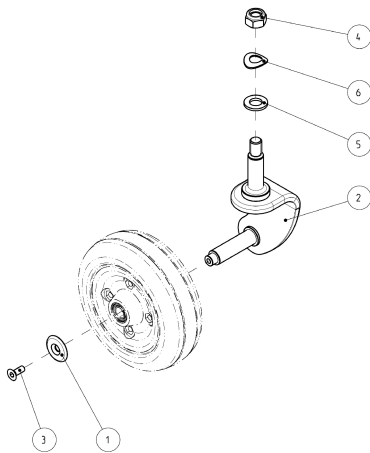

Fig. 6-27

1. Loosen and remove screw (3) including washer (1).
2. Remove castor.
3. Replace castor.

Installing Wheel

1. Install parts in reverse order.
2. When installing wheel, pay attention to correct direction of rotation.
3. Tighten screw (3).

6.9 Shrouds

6.9.1 Removing front shroud

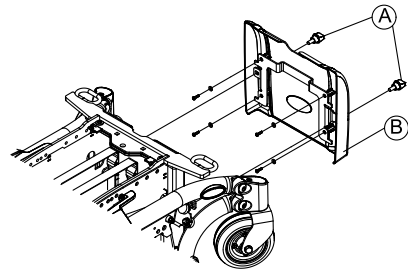

Removing front shroud

1. Remove legrests.
2. Remove screws (A) on front shroud (B).
3. Pull front shroud upwards and remove it.

Installing front shroud

1. Install parts in reverse order.
2. Tighten all screws finger-tight.

6.9.2 Replacing Rear Shroud (Without Operating Hour Counter)



TDX SP2 Low-Rider is equipped with a water protection flap under the rear shroud. The illustration below does not show it.

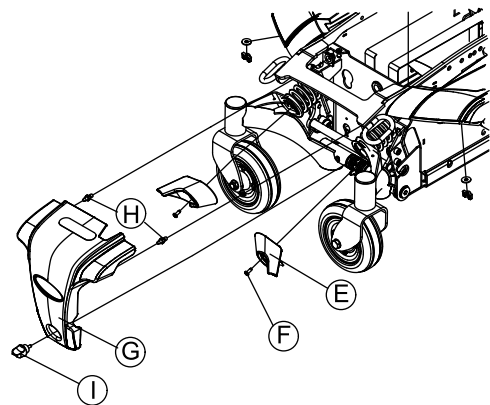

Fig. 6-28

Removing Rear Shroud

1. Loosen and remove hand screw (I) on rear shroud (G).
2. Remove rear shroud.
3. If installed, remove water protection flap.

Installing Rear Shroud

1. Install parts in reverse order.
2. Tighten all screws finger-tight.

6.9.3 Replacing Rear Shroud (With Operating Hour Counter)



- Phillips screwdriver, size 2



TDX SP2 Low-Rider is equipped with a water protection flap under the rear shroud. The illustrations below does not show it.

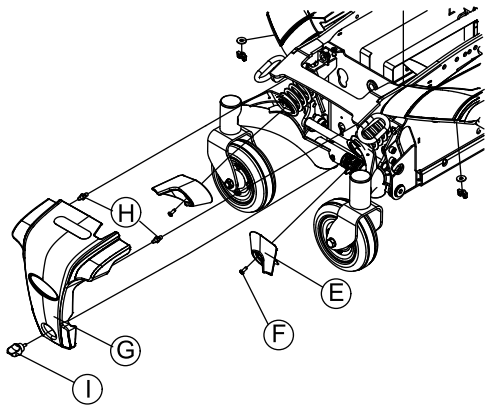

Fig. 6-29

Removing Rear Shroud

1. Loosen and remove hand screw ① on rear shroud ③.
2. Carefully loosen rear shroud. Pay attention to cable of operating hour counter.
3. Take note of positions of cables and sockets. Mark plugs and sockets or take a photo with digital camera.
4. Remove cable of operating hour counter from drive motor.
5. Remove rear shroud.
6. If installed, remove water protection flap.

Installing Rear Shroud

1. Install parts in reverse order.
2. Tighten all screws finger-tight.

6.9.4 Removing top shroud



- Size 2 Phillips screwdriver

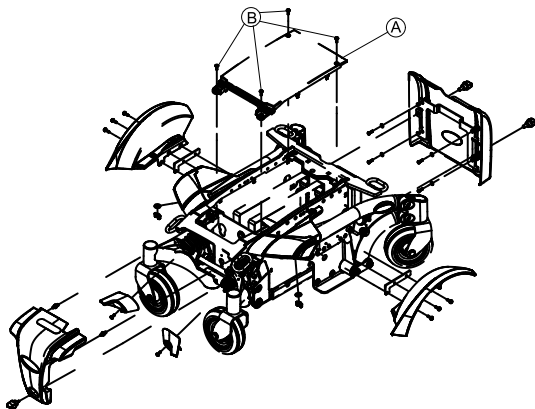

Removing top shroud

1. Remove seat.
2. Undo the four Phillips screws ② on the top shroud ①.
3. Remove top shroud.

Installing top shroud

1. Install parts in reverse order.
2. Tighten all screws finger-tight.

6.9.5 Replacing fender



- 6 mm Allen key
- Two long wooden blocks, min. 14 x 14 x 30 cm
- Torque wrench 0 - 20 Nm (or similar)
- Torque wrench 5 - 25 Nm (or similar)
- Flat screwdriver

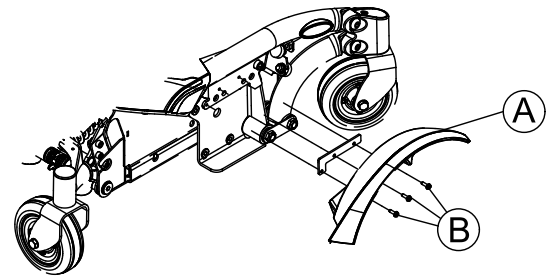

Fig. 6-30

Removing fender

1. Remove drive wheel as described in 6.8.8 *Replacing Drive Wheel (5-Screw Installation)*, page 39.
2. Loosen and remove three slotted screws ②.
3. Remove fender ① from walking beam.

Installing fender

1. Install parts in reverse order.
2. Tighten screws to 4.5 Nm.

6.10 Controls

6.10.1 Replacing Power Module

Various power modules can be installed to the mobility device with a range of different remotes.



CAUTION!

Any changes to drive program can affect driving characteristics and tipping stability of mobility device

- Changes to drive program may only be carried out by trained providers.
- Invacare can only give a warranty for safe mobility device driving behavior - especially tipping stability - for unaltered standard drive programs.



All power modules are delivered with a standard drive program. If you have carried out customer-specific modifications to the drive program, you will have to repeat these changes after installing the new power module.



For replacement of remote in combination with power module and the subsequent selection of LiNX drive programs, see below.



For DX, ACS or ACS 2 electronic module, see earlier revision of this Service manual.



- To adapt drive program: Programming software or hand programming device and system installation manual, available from Invacare.

Removing Power Module

1. Remove rear shroud. See 6.9 *Shrouds*, page 42.
2. Carefully note location of cable and connection locations of various plugs. Either mark each plug and socket, or take a photo with digital camera.
3. Unplug all plugs from power module.

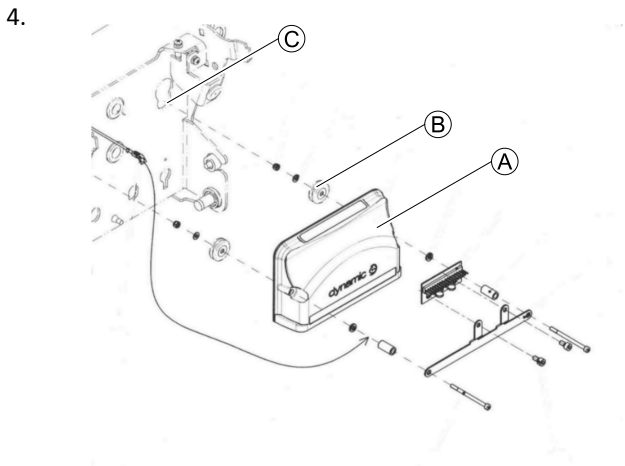



Fig. 6-31

Remove module (A) carefully by lifting rubber stoppers (B) from opening (C).



5. Replace defective module.

Installing Power Module

1. Install parts in reverse order.
2. If LiNX system is used, perform calibration process. See *Suggested programming procedure* in LiNX service manual.
3. Test all functions.

 For instruction on “Drive program selection after component replacement”, see LiNX Service Manual.

6.10.2 Replacing Tilt Actuator (“Fixed Pivot” Tilt)

-  Flat screwdriver
-  Wooden block (approx. 30 x 40 x 29 cm)

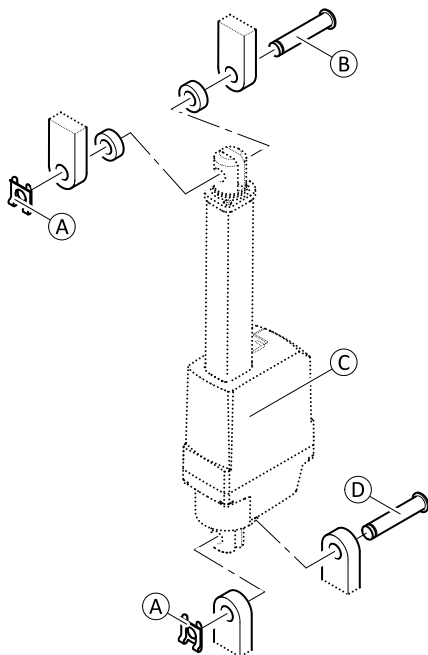



Fig. 6-32 For better view only the actuator, pins, spacers and SL retainer clips are shown.

Removing Actuator

 When removing, take care of small parts such as spacers. Put all small parts down so that they can be installed in the correct sequence.

1. Remove front shroud. See 6.9.1 *Removing front shroud*, page 42.
2. Unplug actuator cable directly on actuator.
3. Remove SL retainer clips (A) on actuator at top and bottom.



CAUTION!

Risk of crushing

Seat comes down when actuator is removed.

- Hold the seat in position while removing the actuator.
- Move the seat into service position and place a wooden block under the backrest, or lower it carefully to the chassis.

4. Remove upper pin (B). Hold seat in position.
5. Move seat into service position. Alternatively, lower it carefully to chassis.
6. Remove lower pin (D) and actuator (C).

Installing Actuator

1. Install parts in reverse order.
2. Test all functions.

6.10.3 Replacing G-Trac Sensor



- 10 mm socket wrench

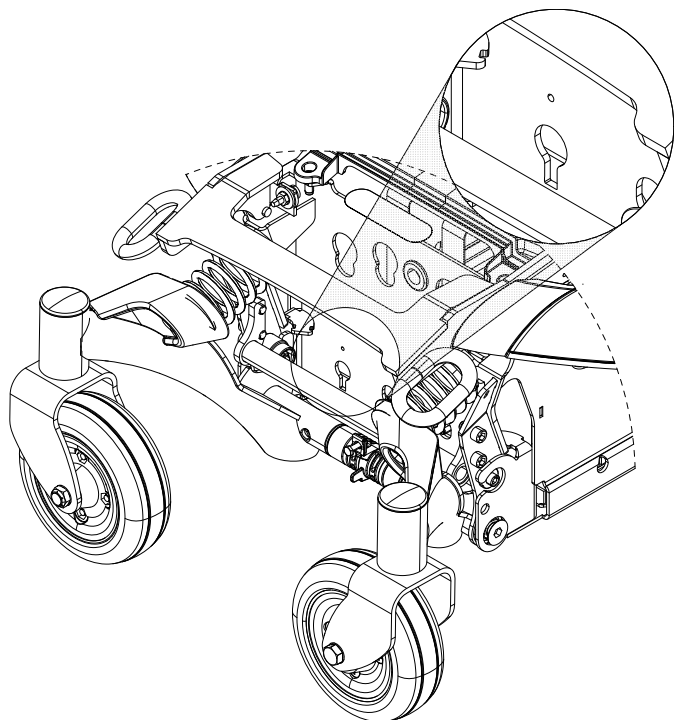

Fig. 6-33

Removing Sensor

1. Turn OFF electronics.
2. Remove rear shroud. See 6.9.2 *Replacing Rear Shroud (Without Operating Hour Counter)*, page 42.
3. Take note of positions of all cables and the sockets that they are connected to. Mark the connectors and sockets or take a photograph with a digital camera.
4. Unplug sensor cable from power module.

5.

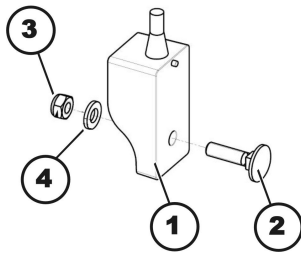

Fig. 6-34

Loosen and remove self-locking nut (3), including washer (4).

6. Remove sensor (1).
7. Replace sensor.

Installing Sensor



CAUTION!

Risk of injury and damage due to uncontrolled movement of mobility device

An incorrect installed sensor sends wrong data to the power module.

- Ensure that sensor is installed with cable pointing upwards.
- Ensure that notch on backside of sensor is engaged in its installation hole.

1. Install parts in reverse order.
2. Check that sensor is installed with cable pointing upwards and correctly engaged notch on backside.
3. Plug in sensor cable to power module.
4. Test all functions.

6.10.4 Replacing Operating Hour Counter/ Connecting Cable

The counter is located on rear shroud.

Removing Counter

1. Switch controls system of wheelchair off.
2. Remove rear shroud. See 6.9 Shrouds, page 42.
3. Loosen and remove nut ① including locking washer ②.
4. Pull mounting bracket ③ off of threaded rod ④.
5. Remove retaining frame ⑤.
6. Pull counter ⑥ forwards out of rear shroud.
7. Unplug cable wires (not shown in the illustration) from pins.
8. Replace counter and cable respectively.

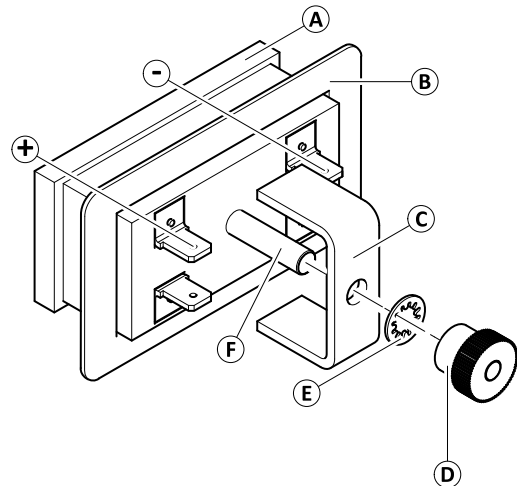

Fig. 6-35

Installing Counter



Risk of damage

If counter is wrongly connected. If plus and minus wires are connected wrong way, it will damage electronic components of operating hour counter.

- Make sure cable is connected correctly.

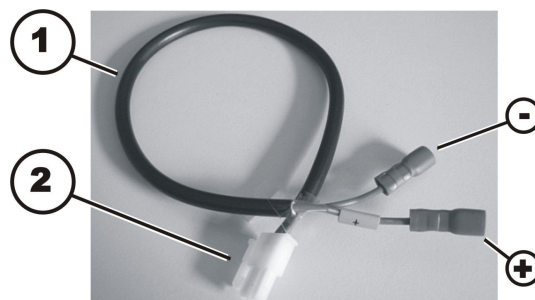

1. Plug in blue wire (-) to pin 2 and brown wire to pin 1 on counter, which is marked with a "minus" symbol. The brown wire is additionally marked with yellow sleeve with "plus" symbol on it.
2. Insert cable from outside through cut-out for counter located in rear.
3. Position counter (A) in cut-out.
4. Reposition retaining frame (B).
5. Place mounting bracket (C) on threaded rod (F) so that mounting bracket presses retaining frame on shroud.
6. Place locking washer (E) and nut (D) on threaded rod.
7. Tighten nut hand-tight.
8. Install shroud.

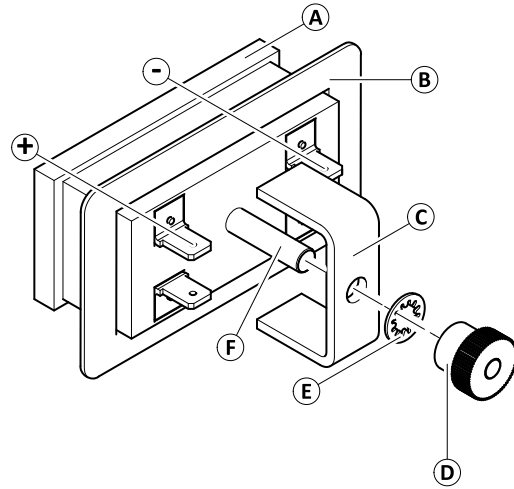

Fig. 6-36

6.10.5 Updating Software

See LiNX service manual.

6.10.6 Replacing USB charger

- 4 mm Allen wrench

- i** When charger overheats, it stops working. Rail under the seat serves to dissipate heat.
- Always mount USB charger in first third of the rail of telescopic seat frame.

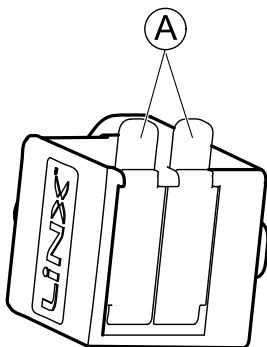
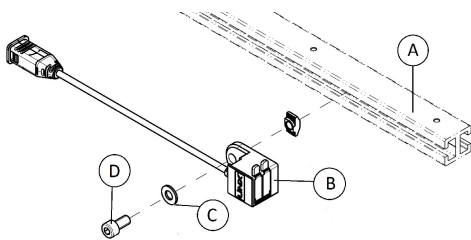

Removing USB charger

1. Loosen and remove screw (D) including washer (C).
2. Take off USB charger (B) from rail of telescopic seat frame (A).
3. Replace USB charger.

Installing USB charger

1. Install parts in reverse order.

6.10.7 Checking cable

- 5/8" Allen key
- Size 2 Phillips screwdriver
- Oblique pliers
- Cable ties

- 1.

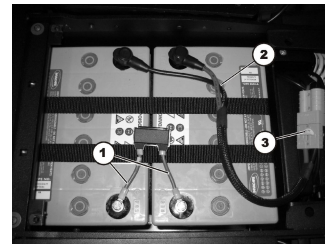

Remove shrouds, disconnect battery plugs and pull batteries out of battery compartment as described in *6.11.3 Making Batteries Accessible, page 48*.

2. Check fuse cable (1), battery cable (2) and battery plug (3) for visible damage and crushing locations.
3. Replace any damaged cables.
- 4.

- i** The position of the plugs is different for other electronic modules. The procedure for checking is otherwise identical. The position of the plugs is described in revision 11 of this manual or in LiNX Service Manual".

Check all cables for visible damage and crushing locations. Replace any damaged cables.

5. Pull each plug carefully. Plug should not come out of socket.
6. If one of plugs is loose, press it back into socket with light pressure. Plug must engage.
7. Checked to make sure that plug is now firmly in its socket. If not, repeat previous step.
8. Install parts in reverse order.
9. Test all functions.

6.10.8 Cable routing

- Size 2 Phillips screwdriver
- Oblique pliers
- Cable ties

1. Remove rear shroud as described in 6.9.2 *Replacing Rear Shroud (Without Operating Hour Counter)*, page 42.
2. When routing cables in rear section, make sure that rear wheel stabilizers are movable.
- 3.

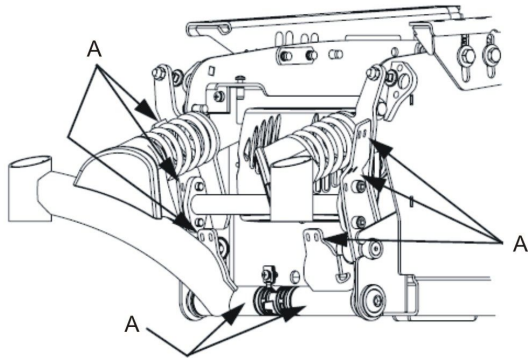

Fix cable with cable ties at locations marked Ⓐ.

4. Make sure cable has enough play so that all movable parts can move freely without stretching, clamping or chafing cable.
5. Route cable in the same manner underneath seat and control shroud.

6.11 Batteries



CAUTION!

Injury hazard and possible material damages if batteries are handled improperly

The installation of new batteries may only be carried out by authorised specialists.

- Observe the warning information on the batteries.
- Only use battery versions stated in the specifications.



CAUTION!

Fire and burns hazard if battery terminal is bypassed

- Take great care to ensure that the battery terminals are never short-circuited with tools or mechanical mobility device parts.
- Ensure that the battery terminal caps have been replaced if you are not working on the battery terminals.



CAUTION!

Risk of crushing

- Batteries can be extremely heavy. This results in injury hazards to your hands.
- Handle the batteries with care.
 - Ensure that batteries do not fall to the ground when removed from chassis.
 - Pay attention to hands.
 - Use proper lifting techniques.



WARNING!

Burn hazard

Injury hazard due to discharged acid.

- Always wear acid-proof protective gloves when handling batteries.
- Always wear protective goggles when handling batteries.

What to do if acid is discharged

- Always take clothing which has been soiled by or dipped in acid off immediately!
- Rinse any areas of your skin which has come into contact with battery acid off immediately with plenty of water!

If contact with eyes is made

- You should also consult an eye specialist immediately afterwards!



When removing, take care of small parts such as screws and washers. Put all small parts down so that they can be installed in correct sequence.

6.11.1 General Instructions on Handling Batteries

- Never mix and match different battery manufactures or technologies, or use batteries that do not have similar date codes.
- Never mix gel with AGM batteries.
- The batteries reach their end of life when the drive range is significantly smaller than usual. Contact your provider or service technician for details.
- Always have your batteries installed by a properly trained mobility device technician or a person with adequate knowledge. They have the necessary training and tools to do the job safely and correctly.

6.11.2 Handling Damaged Batteries Correctly



CAUTION!

Corrosion and burns from acid leakage if batteries are damaged

- Remove clothes that have been soiled by acid immediately.

After contact with skin:

- Immediately wash affected area with lots of water.

After contact with eyes:

- Immediately rinse eyes under running water for several minutes; consult a physician.

- Always wear safety goggles and appropriate safety clothing when handling damaged batteries.
- Place damaged batteries in an acid-resistant receptacle immediately after removing them.
- Only ever transport damaged batteries in an appropriate acid-resistant receptacle.
- Wash all objects that have come into contact with acid with lots of water.

Disposing of Dead or Damaged Batteries Correctly

Dead or damaged batteries can be given back to your provider or directly to Invacare.

6.11.3 Making Batteries Accessible

-  • Phillips screwdriver, size 2
- 5/32 in Allen key
- 13 mm wrench
- Two wooden blocks (approx. 30 x 40 x 29 cm)

1.

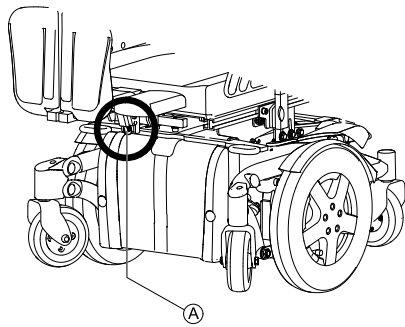

Fig. 6-37

Remove side-mounted legrests if fitted. A centre-mounted, manually adjustable legrest should be either put in its top position by turning the spindle **A** or removed. Elevate powered legrests to top position.

2.

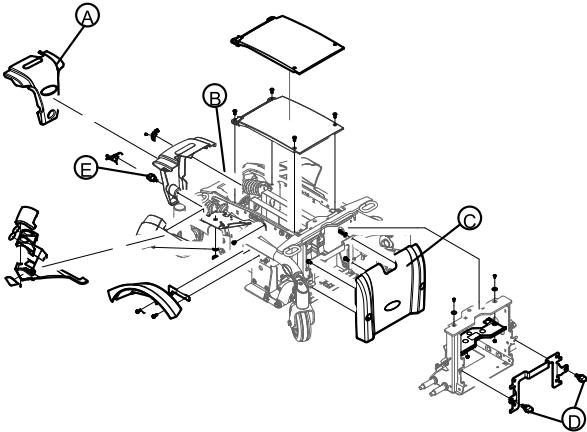

Fig. 6-38

Remove hand screw **E** on rear shroud **A**.

3. Remove rear shroud.
4. Unplug battery plugs **B**.
5. Remove hand screws **D** on front shroud **C**.
6. Pull front shroud upwards and remove it.
7. Remove tilt actuator if fitted. See 6.10.2 *Replacing Tilt Actuator ("Fixed Pivot" Tilt)*, page 44.

8.

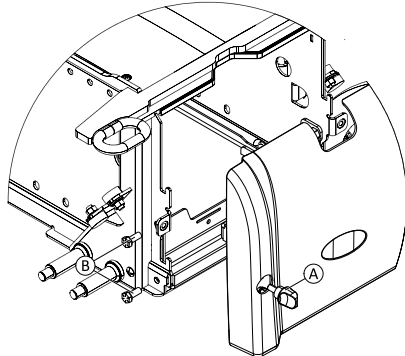



Fig. 6-39

Loosen screws **B** on both sides. Do not remove them.

6.11.4 Replacing Batteries (60 Ah / 73 Ah)

-  • Phillips screwdriver, size 2
- 5/32 in Allen key
- 11 mm wrench
- Wooden block (approx. 30 x 40 x 29 cm)



TDX SP2 Low-Rider does not have terminal caps. Take special care NOT to shorten battery terminals.

Removing Batteries

1. Make batteries accessible. See 6.11.3 *Making Batteries Accessible*, page 48.
- 2.

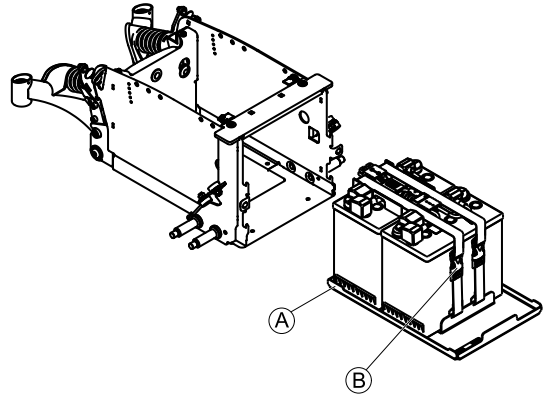

Fig. 6-40

Pull out battery tray **A**.

3.

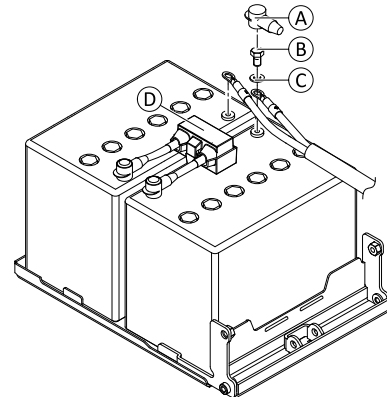

Fig. 6-41



TDX SP2 Low-Rider does not have terminal caps.

Remove terminal caps **A**.

4. Loosen and remove terminal screws **B** including washers **C**. First remove negative terminal screw. After this, remove positive terminal screw.
5. Remove connection cable with main fuse **D**.

6.

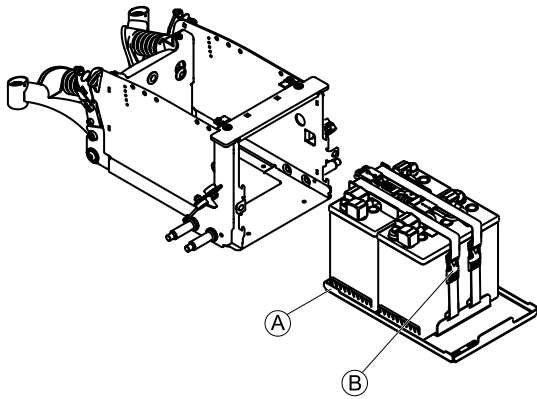

Fig. 6-42

Open battery straps **B**.

7. Remove batteries.

Installing Batteries

1. Install batteries in reverse order.
2. Make sure that battery box sockets/plugs have been correctly refitted. A polarity diagram is located in battery box shroud.

6.11.5 Replacing Batteries (50 Ah)

- | | |
|---|---|
|  | <ul style="list-style-type: none"> • 3/8 in wrench • 19 mm wrench • Torque wrench 5 - 25 Nm (or similar) • Oblique pliers • Wooden block (approx. 30 x 40 x 29 cm) |
|---|---|

Removing Batteries

1. Make batteries accessible. See 6.11.3 Making Batteries Accessible, page 48.
2. Pull out battery tray.
- 3.

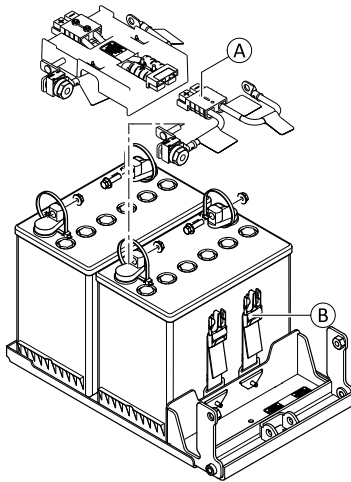

Fig. 6-43

Disconnect plug **A**.

4. Open battery straps **B**.
5. Remove batteries from mobility device.

6.

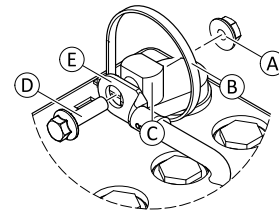



Fig. 6-44 Detail view of negative terminal

Remove cable ties **B** on all terminals.

7. Remove terminal caps.
8. Remove terminal screw of negative terminal.
 - a. Loosen and remove nut **A**.
 - b. Remove terminal screw **D** together with cable lug **E** from battery terminal **C**.
9. Repeat previous step to remove terminal screw of positive terminal.
10. Remove cable harness.

Installing Batteries

 Connect negative terminal first, then positive terminal.

1. Install parts in reverse order. Tighten screws to 7 Nm.
2. Make sure that battery box sockets and plugs are correctly installed. A polarity diagram is located in battery box shroud.
- 3.

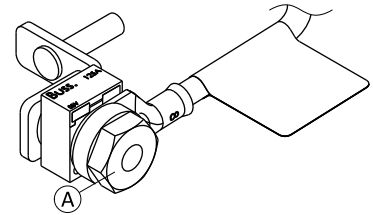

Fig. 6-45

Check nut **A** on positive terminal for tight fit. If required, tighten to 7 Nm.

4. Carefully reposition battery terminal caps and secure them with a cable tie to prevent them from possibly slipping out of place.

6.11.6 Replacing Batteries / Battery Cables

To replace fuse, battery cable with fuse attached to it must be replaced.

Removing batteries/battery cables

1. Remove batteries. See 6.11.3 Making Batteries Accessible, page 48.

Positive Terminal (+)

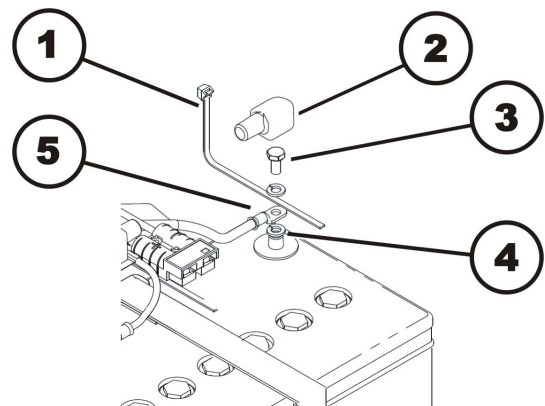

Fig. 6-46

1. Remove cable ties (1) with side cutting pliers.
2. Lift battery terminal cap (2) off and move it up cable and out of way.
3. Loosen battery terminal screw (3).
4. Remove battery terminal screw together with both washers and cable lug (5) from battery terminal (4).

Negative Terminal (-)

1. Repeat steps of procedure on negative terminal of battery.
2. Replace batteries and/or battery cables.

Installing Batteries / Battery Cables

1. Install parts in reverse order. Connect negative terminal first, then positive terminal.
2. Make sure battery box sockets and plugs are correctly installed. A polarity diagram is located in the battery box shroud.
3. Carefully reposition battery terminal caps and secure them a with cable tie to prevent them from possibly slipping out of place.

6.11.7 Checking and replacing main fuse



**CAUTION!
Risk of fire**

An electric short can cause extremely high currents which can result in spark formation and fire

- Always use an original strip fuse with the approved amperage.
- If main fuse has blown, first rectify the cause before fitting a new one.

Risk of fire

Fitting the incorrect strip fuse causes a risk of fire

- Only fix strip fuses in the sequence shown in the image on the right.
- Tighten nuts with 3.3 or 3.5 Nm.

Fitting original strip fuse in correct sequence

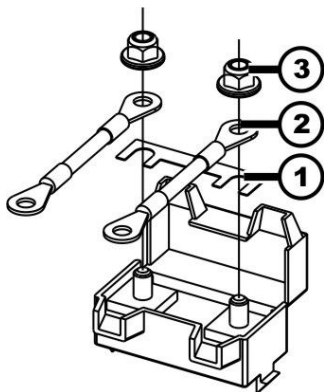

1. Strip fuse (1)
2. Cable lug (2)
3. DIN 6923 nut (3)

- 5/8" (16 mm) Allen key
- 4 mm flat screwdriver
- 8 mm wrench
- Torque wrench 0-20 Nm (or similar)

If fuseholder is damaged, you can replace it completely with battery cables.

Removing main fuse

1. Remove battery compartment shroud, disconnect battery plugs and pull batteries out of battery compartment as described in 6.11.3 Making Batteries Accessible, page 48.
- 2.

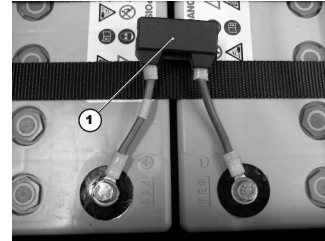

The fuseholder (1) is located on top of batteries.

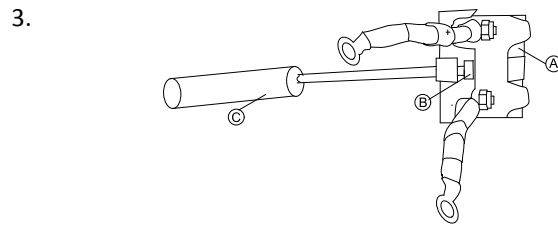

Pry open snap hook (B) with flat screwdriver (C). Fuseholder shroud (A) is open.

Older fuseholder versions may be locked with a cable tie. If so, cut open cable tie to access fuse strip.

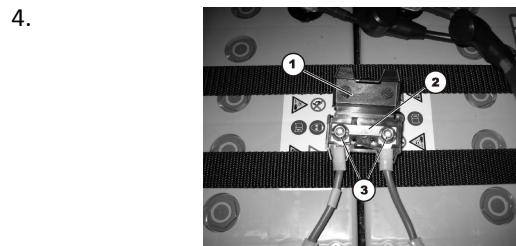

You can see strip fuses (2) once fuse holder (1) is open.

5. If strip fuse has blown, you must first ascertain and rectify the cause of fault.
6. The main fuse may only be replaced once fault has been rectified.
7. Remove nuts (3).
8. Replace strip fuse.

Installing main fuse

1. Install parts in reverse order.
2. Test all functions.

Make sure to press two parts of fuse holder shroud together until it snaps.

If older fuseholder version is used, lock fuseholder with UL94V0 cable tie.

6.12 Lighting unit

6.12.1 Replacing front bulb (conventional lighting system)

- Size 2 Phillips screwdriver

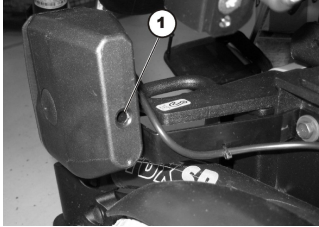

1. Loosen and remove screw (1) on rear of headlight/indicator combination.
2. Remove glass.
3. Replace defective bulb.
4. Close glass and tighten Phillips screw finger-tight.

6.12.2 Replacing headlight complete (conventional lighting system)



- Phillips screwdriver size 2
- Oblique pliers
- Cable ties

Removing headlight

1. Remove rear shroud as described in 6.9.2 *Replacing Rear Shroud (Without Operating Hour Counter)*, page 42.
2. Carefully note location of cable and connection locations of the various plugs. Either mark each plug and socket, or take a photograph with a digital camera.
- 3.

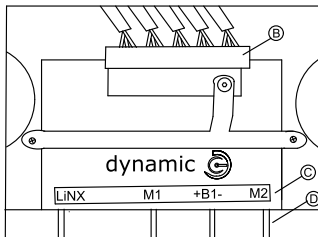

On the illustration you can see lighting PCB **B** for power module **C**, optional cross connector **D**.

4. Loosen cable leading to lighting PCB from front headlight affected.
5. Remove all cable ties and pull cable out of mobility device.
- 6.

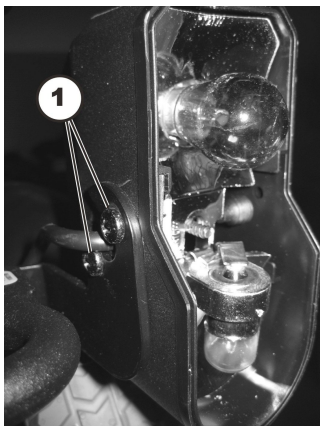

Loosen and remove two screws which hold front headlight.

7. Replace headlight unit.

Installing front headlight

1. Install parts in reverse order. Route cables carefully and fix them with cable ties.
2. Test all functions.

6.12.3 Replacing headlight complete (LED lighting system)



- Allen key 4 mm
- Oblique pliers
- Cable ties

Removing headlight

1. Remove rear shroud as described in 6.9.2 *Replacing Rear Shroud (Without Operating Hour Counter)*, page 42.
2. Carefully note location of cable and the connection locations of the various plugs. Either mark each plug and socket, or take a photograph with a digital camera.
- 3.

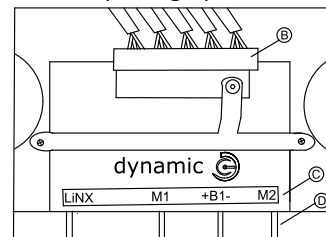

In the illustration you can see lighting PCB **B**, power module **C** and optional cross connector **D**.

- 4.

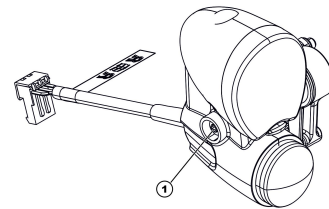

Loosen cable leading to lighting PCB from headlight affected.

5. Remove all cable ties and pull cable out of wheelchair.
6. Loosen screw (1) and remove front bulb from mounting.
7. Replace headlight.

Installing headlight

1. Install parts in reverse order.
2. Route cables carefully and fix them with cable ties. Pay attention to 6.10.8 *Cable routing*, page 46.
3. Test all functions.
4. Tighten all screws finger-tight.
5. Test all functions.
6. Adjust headlight roughly using grid. User can carry out final adjustment according to user manual.

6.12.4 Replacing front lamp holder (conventional lighting system)



- Size 2 Phillips screwdriver
- 13 mm socket wrench

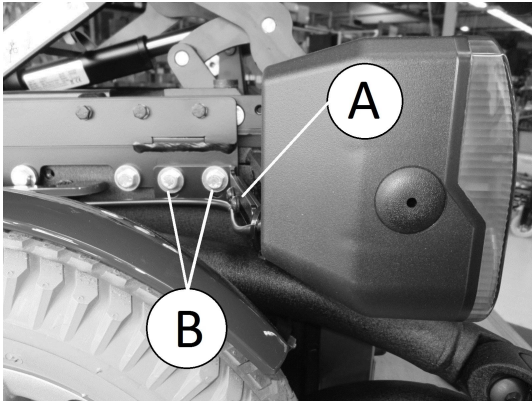

Removing front lamp holder

1. Remove complete headlight as described in 6.12.2 *Replacing headlight complete (conventional lighting system)*, page 51.
2. Loosen and remove screw (B) and washer.
3. Remove front lamp holder (A).

Installing front lamp holder

1. Install parts in reverse order.
2. Test all functions.

6.12.5 Replacing front lamp holder - (conventional lighting system)

-  • Phillips screwdriver
 • 4 mm Allen key
 • 6 mm Allen key
 • 13 mm socket wrench
 • 10 mm socket wrench

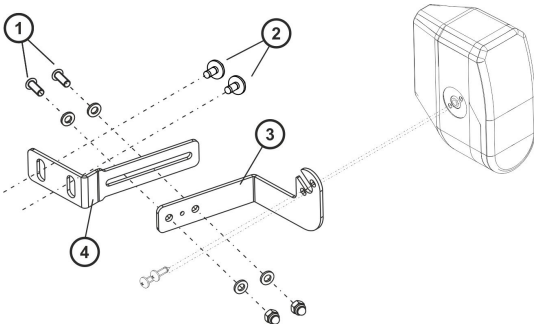

Removing bulbholder

1. Remove headlight completely as described in 6.12.2 *Replacing headlight complete (conventional lighting system)*, page 51.
2. Loosen and remove screws (2) with washers.
3. Remove lamp holder (4).
4. Moving bulbholder (3):
 - Loosen two screws (1).
 - Move lamp holder (3) to correct position.
 - Install two screws (1) including washers and nuts.

Refitting bulbholder

1. Install parts in reverse order.
2. Check all functions.

6.12.6 Replacing front lamp holder - (LED lighting system)

-  • Phillips screwdriver
 • 4 mm Allen key
 • 6 mm Allen key
 • 13 mm socket wrench
 • 10 mm socket wrench

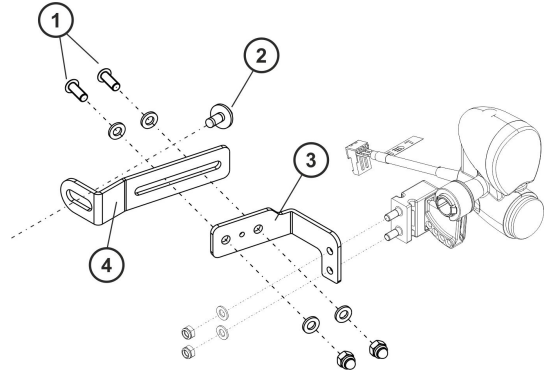

Removing lamp holder

1. Remove complete headlight as described in 6.12.3 *Replacing headlight complete (LED lighting system)*, page 51.
2. Loosen and remove two retaining screws (2) with washers.
3. Remove lamp holder (4).
4. Moving lamp holder (3):
 - Loosen two screws (1).
 - Move lamp holder (3) into position.
 - Install two screws (1) including washers and nuts.

Installing lamp holder

1. Install parts in reverse order.
2. Test all functions.

6.12.7 Replacing rear bulb (conventional lighting system)

-  • Phillips screwdriver size 2

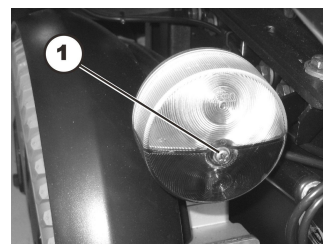

1. Loosen and remove screw in glass over rear light/indicator combination.
2. Remove glass.
3. Replace defective bulb.
4. Install glass and tighten screw finger-tight.

6.12.8 Replacing rear light complete - (conventional lighting system)

-  • Size 2 Phillips screwdriver
 • 8 mm Socket wrench

Removing rear light

1. Remove rear shroud as described in 6.9.2 *Replacing Rear Shroud (Without Operating Hour Counter)*, page 42.
- 2.

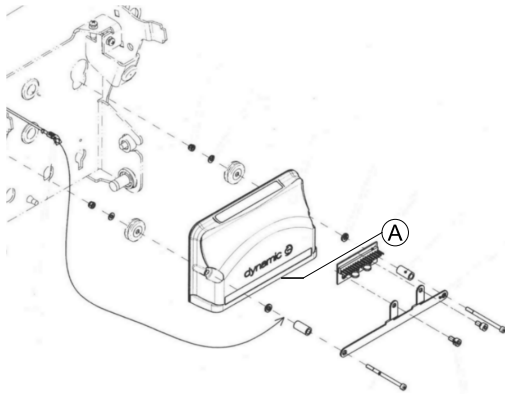

Carefully note location of cable and connection locations of various plugs on power module (A). Either mark each plug and socket, or take a photograph with a digital camera.

3. Loosen cable leading to lighting PCB from rear light.
4. Remove all cable ties and pull cable out of mobility device.
- 5.

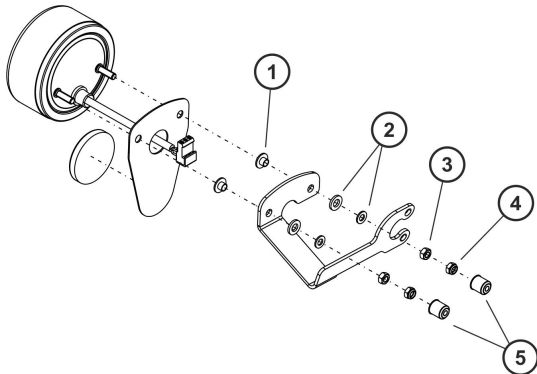

Remove two protection caps (5).

6. Loosen and remove two nuts (4) / (3) including washers (2) and protection caps (1).
7. Replace rear light.

Installing rear light

1. Install parts in reverse order.
2. Test all functions.

6.12.9 Replacing complete rear light - (LED lighting system)

- 4 mm Allen key
- 13 mm socket wrench

Removing rear light

1. Remove rear shroud as described in 6.9.2 *Replacing Rear Shroud (Without Operating Hour Counter)*, page 42.
2. Carefully note location of cable and connection locations of various plugs. Either mark each plug and socket, or take a photograph with a digital camera.

3.

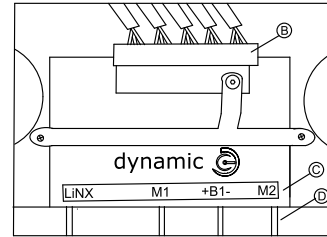
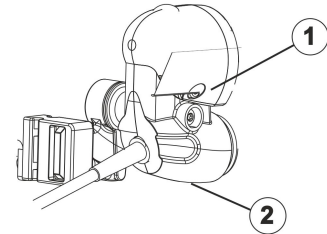

Illustration shows lighting PCB (B) for power module (C), the optional cross connector (D).

4. Loosen cable leading to lighting PCB from rear light affected.
5. Remove all cable ties and pull cable out of wheelchair.
- 6.



Loosen wing nut (2).

7. Remove glass (1).
- 8.

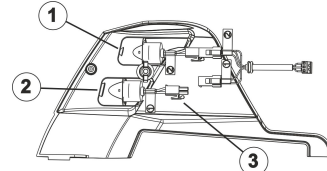

Open connector plug (3) for the rear light which needs to be replaced.

9. The rear lights are only clamped in by the plastic housing. If required, replace the red rear light (2) or the indicator (1). The cables are labelled appropriately.

Install rear light

1. Install parts in reverse order.
2. Tighten all screws finger-tight again.
3. Test all functions.

6.12.10 Replacing rear lamp holder - (conventional lighting system)

- Size 2 Phillips screwdriver
- 8 mm socket wrench
- 3/16" Allen key

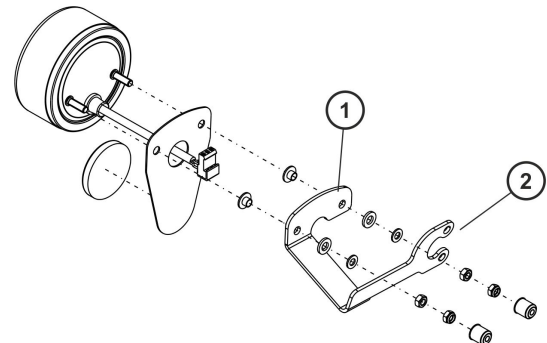

Removing rear lamp holder

1. Remove complete rear light as described in 6.12.8 *Replacing rear light complete - (conventional lighting system)*, page 52.
2. Loosen and remove two screws (2) on chassis including washers.
3. Replace lamp holder (1).

Installing rear lamp holder

1. Install parts in reverse order.
2. Test all functions.

6.13 Seating

- For seat systems —Modulite and ULM, refer to the corresponding manual.
- Older specifications have been described in revision 11 of this service manual.

6.14 Mounting Dahl Docking System

 For more information about spare parts, accessory part installation in vehicles and maintenance of the Dahl Docking system, contact Dahl Engineering www.dahlengineering.dk.

 To retrofit a mobility device with a Dahl Docking system, it is imperative, that the mobility device is equipped with the correct adapter plate. This adapter plate must be threaded to fix the lock plate of the Dahl Docking system underneath the mobility device. The maximum kerb weight of the mobility device must not exceed 200 kg.

-
-  • TX27 Torx key
• Low-strength thread locking adhesive (Loctite 222 or similar)
-

1. Remove batteries. See *Removing Batteries*.
- 2.

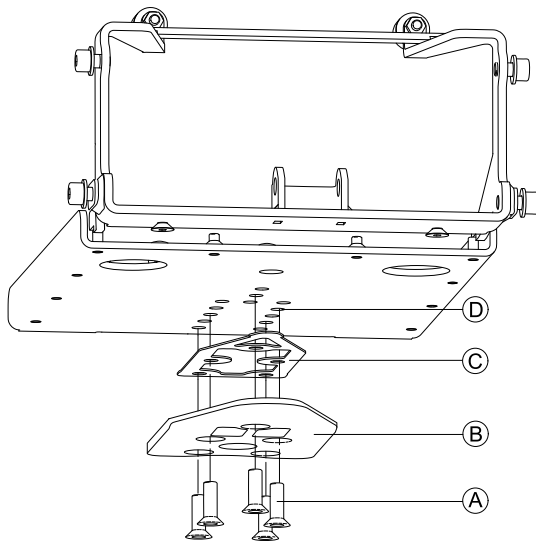



Fig. 6-47

Place screws **A**, lock plate **B** and 8 mm spacer **C** on adapter plate **D**.

 8 mm spacer is mandatory. Additional spacers can be mounted to lock plate.

3.

! Do not use any other screws than those supplied from Dahl Engineering (Part No. 502800). Standard countersunk M8 screws are not strong enough in the event of a collision.

Tighten screws (16 - 18 Nm).

4. Mark where to cut screws.
5. Remove screws, lock plate and spacer.

6. Cut screw.

 It is very important to check correct length of screws. If screws are too short to reach through threads, screws do not have strength to carry required load. If screws are too long, batteries or other components can be damaged. If screws are cut too short, replace them with original Dahl screws only.

7. Apply thread locking adhesive on screws.
8. Tighten lock plate and spacer with screws (16 - 18 Nm).
9. Connect mobility device with Dahl Docking station. Make sure lock plate is securely locked and all release methods work as intended. For more information about using the Dahl Docking system, see user manual.

Installation of Dahl Docking System in Vehicles

Only professional companies in the business of converting or building mobility device accessible vehicles can order the Dahl Docking system from Dahl Engineering.

A qualified and experienced technician must carry out the installation. Dahl Engineering can provide vehicle specific installation instructions for a large range of vehicles.

Invacare Distributors

Australia:

Invacare Australia Pty. Ltd.
1 Lenton Place, North Rocks NSW
2151
Australia
Phone: 1800 460 460
Fax: 1800 814 367
orders@invacare.com.au
www.invacare.com.au

United Kingdom:

Invacare Limited
Pencoed Technology Park, Pencoed
Bridgend CF35 5AQ
Tel: (44) (0) 1656 776 222
Fax: (44) (0) 1656 776 220
uk@invacare.com
www.invacare.co.uk

Canada:

Invacare Canada L.P.
570 Matheson Blvd East, Unit 8
CDN Mississauga, On. L4Z 4G4
Phone: (905) 890 8300
Toll Free: 800.668.5324
www.invacare.ca

Eastern Europe, Middle East & CIS:

Invacare EU Export
Am Achener Hof 8
D-88316 Isny
Tel: (49) (0)7562 700 397
eu-export@invacare.com
www.invacare-eu-export.com

Ireland:

Invacare Ireland Ltd,
Unit 5 Seatown Business Campus
Seatown Road, Swords, County Dublin
Tel : (353) 1 810 7084
Fax: (353) 1 810 7085
ireland@invacare.com
www.invacare.ie

New Zealand:

Invacare New Zealand Ltd
4 Westfield Place, Mt Wellington 1060
New Zealand
Phone: 0800 468 222
Fax: 0800 807 788
sales@invacare.co.nz
www.invacare.co.nz

