

Rea Clematis Pro

en **Manual Wheelchair
User Manual**

This manual **MUST** be given to the user of the product. **BEFORE** using this product, this manual **MUST** be read and saved for future reference.



Contents

1 General	4		
1.1 Introduction	4		
1.2 Delivery check	4		
1.3 Symbols in this Manual	4		
1.4 Warranty Information	4		
1.5 Limitation of Liability	4		
1.6 Compliance	4		
1.6.1 Product-specific standards	4		
1.7 Service Life	5		
2 Safety	5		
2.1 Safety Information	5		
2.2 Safety information on electromagnetic interference (EMI)	6		
2.3 Labels and symbols on the product	7		
2.3.1 Identification label	7		
2.3.2 Posture belt information label	7		
2.3.3 Snap hook system labels	7		
2.3.4 Symbols on Electrical Version	7		
3 Product Overview	7		
3.1 Product description	7		
3.2 Intended use	7		
3.2.1 Intended users	7		
3.2.2 Indications	7		
3.2.3 Contra-indications	8		
3.3 Main parts of the wheelchair	8		
3.4 Parking brakes	8		
3.5 Backrest	8		
3.5.1 Adjusting the "Laguna" tension adjustable backrest	8		
3.5.2 Adjusting the backrest angle	9		
3.6 Tilting seat and backrest	9		
3.7 Push handles/push bars	12		
3.7.1 Adjusting the height of connected push handles	12		
3.7.2 Adjusting the height of the push bar	12		
3.7.3 Adjusting the angle of the push bar	13		
3.8 Seat adjustments	13		
3.8.1 Adjusting the seat width (optional, 2 positions)	13		
3.8.2 Adjusting the seat depth	13		
3.8.3 Adjusting the legrest width	13		
3.8.4 Adjusting the seat cushion	13		
3.9 Leg rests	14		
3.9.1 Swing away leg rests	14		
3.9.2 Swing away, angle adjustable leg rests	14		
3.10 Anti-tip device	16		
3.10.1 Activating the anti-tip device	16		
3.10.2 Deactivating the anti-tip device	16		
3.10.3 Setting the height	16		
3.10.4 Using the anti-tip device as a tipping aid	16		
4 Options	16		
4.1 Headrest and neckrest	16		
4.1.1 Adjusting the headrest height	17		
4.1.2 Adjusting the headrest depth and angle	17		
4.1.3 Adjusting the headrest width	17		
4.2 Hemiplegic armrest	17		
4.3 Abduction cushion	17		
4.4 Trunk support with fixed arm or swing-away arm	18		
4.4.1 Adjusting the fixed arm	18		
4.4.2 Trunk swing-away support	18		
4.5 Adjusting the drip stand	18		
4.5.1 Drip stand height	19		
4.5.2 Drip stand angle	19		
4.6 Table trays	19		
4.6.1 Adjusting the depth of the table tray	19		
4.6.2 Locking the table tray	19		
4.6.3 Swing away table	20		
4.6.4 Adding table tray cushions	20		
4.6.5 Adding elbow cushions	20		
4.7 Half tray	20		
4.7.1 Mounting the half tray	21		
4.7.2 Adjusting the half tray	21		
4.7.3 Adding a half tray cushion	21		
4.8 Posture belt	21		
4.8.1 Closing and opening the posture belt	21		
4.8.2 Adjusting the length of the posture belt	22		
4.8.3 Posture belt mounting	22		
4.9 Attachment when using positioning belt	22		
5 Setup	23		
5.1 Safety information	23		
5.2 Delivery check	23		
5.3 Assembly	23		
5.4 Installing the backrest	23		
5.4.1 Installing the backrest — gas piston	23		
5.4.2 Installing the safety shackle — electrical piston	23		
5.5 Inserting and removing the armrests	23		
5.6 Adjusting the armrest height	24		
5.7 Adjusting the armrest/side rest depth	24		
5.8 Installing and removing rear wheels	24		
5.9 Angle adjustable leg rests	25		
5.10 Fixed leg rests	25		
5.11 Mounting the table tray	25		
6 Using the wheelchair	25		
6.1 General warnings — usage	25		
6.2 Brakes	25		
6.2.1 Using the user operated brake	25		
6.2.2 Using the foot operated brake	25		
6.2.3 Using the one arm brake	26		
6.2.4 Using the carer-operated brake	26		
6.3 Using the tilt and recline function	26		
6.3.1 Tilting / reclining from an upright position	26		
6.3.2 Rising from a tilted and reclined position	26		
6.4 Move to and from the wheelchair	27		
6.5 Driving and steering the wheelchair	27		
6.6 Negotiating steps and kerbs	27		
6.6.1 Going down a step with an assistant	27		
6.6.2 Going up a step with an assistant	27		
6.7 Going up and down stairs	28		
6.8 Negotiating ramps and slopes	28		
6.9 Stability and balance when seated	28		
6.9.1 Leaning forwards	28		
6.9.2 Reaching backwards	29		
7 Transport	29		
7.1 Lifting the wheelchair	29		

7.2	Disassembly for transport	29
7.2.1	Folding the backrest	29
7.2.2	Push handles/ push bar	30
7.2.3	Angle adjustable leg rests	30
7.2.4	Fixed leg rests	30
7.2.5	Front castors	30
7.2.6	Rear wheels	30
7.2.7	Removing and installing the anti-tip device	30
7.3	Transporting the mobility device without occupant	30
7.4	Transporting the occupied wheelchair in a vehicle	30
7.4.1	Securing the wheelchair and its occupant	31
7.4.2	Securing the wheelchair with a 4-point restraint system	32
7.4.3	Fastening the 3-point belt restraint	32
8	Maintenance	33
8.1	Safety information	33
8.2	Daily performance check	33
8.3	Maintenance schedule	33
8.4	Maintenance electrical version	34
8.5	Cleaning and disinfection	35
8.5.1	General safety information	35
8.5.2	Cleaning intervals	35
8.5.3	Cleaning	35
8.5.4	Washing	35
8.5.5	Multi-stretch polyurethane (PU) coated fabric	35
8.5.6	Disinfection	36
9	After use	36
9.1	Storage	36
9.1.1	Storage electrical version	36
9.2	Disposal	36
9.2.1	Disposal electrical version	37
9.3	Reconditioning	37
10	Troubleshooting	37
10.1	Safety information	37
10.2	Identifying and repairing faults	38
10.3	Identifying and repairing faults, electrical version	38
11	Technical data	39
11.1	Dimensions and weights	39
11.2	Maximum weight of removable parts	40
11.3	Tyres	40
11.4	Materials	40
11.5	Environmental conditions	40
11.6	Environmental conditions electrical version	40
11.7	Electrical system — models equipped with electric tilt and backrest	40
11.8	Electromagnetic compliance (EMC)	41

1 General

1.1 Introduction

This user manual contains important information about the handling of the product. To ensure safety when using the product, read the user manual carefully and follow the safety instructions.

Only use this product if you have read and understood this manual. Seek additional advice from a healthcare professional who is familiar with your medical condition and clarify any questions regarding the correct use and necessary adjustment with the healthcare professional.

Note that there may be sections in this document, which are not relevant to your product, since this document applies to all available models (on the date of printing). If not otherwise stated, each section in this document refers to all models of the product.

The models and configurations available in your country can be found in the country-specific sales documents. Invacare reserves the right to alter product specifications without further notice.

Before reading this document, make sure you have the latest version. You find the latest version as a PDF on the Invacare website.

If you find that the font size in the printed document is difficult to read, you can download the PDF version from the website. The PDF can then be scaled on screen to a font size that is more comfortable for you.

For more information about the product, for example product safety notices and product recalls, contact your Invacare distributor. See addresses at the end of this document.

In case of a serious incident with the product, you should inform the manufacturer and the competent authority in your country.

1.2 Delivery check

Any transport damage must be reported immediately to the transport company. Remember to keep the packaging until the transport company has checked the goods and a settlement has been reached.

1.3 Symbols in this Manual

Symbols and signal words are used in this document and apply to hazards or unsafe practices which could result in personal injury or property damage.

This document is printed in greyscale. For your information, the safety messages have the following colour coding according to ANSI Z535.6: Danger (Red), Warning (Orange), Caution (Yellow) and Notice (Blue).

See the information below for definitions of the signal words.



CAUTION!

Indicates a hazardous situation that could result in minor or slight injury if it is not avoided.



NOTICE!

Indicates a hazardous situation that could result in damage to property if it is not avoided.



Tips and Recommendations

Gives useful tips, recommendations, and information for efficient, trouble-free use.



Tools

Gives useful tips, recommendations, and information for efficient, trouble-free use.



Triman

Indicates recycling and sorting rules (only relevant for France).



UK responsible person

Indicates if a product is not manufactured in the UK.

1.4 Warranty Information

We provide a manufacturer's warranty for the product in accordance with our General Terms and Conditions of Business in the respective countries.

Warranty claims can only be made through the provider from whom the product was obtained.

1.5 Limitation of Liability

Invacare accepts no liability for damage arising from:

- Non-compliance with the user manual
- Incorrect use
- Natural wear and tear
- Incorrect assembly or set-up by the purchaser or a third party
- Technical modifications
- Unauthorised modifications, combinations and/or use of unsuitable spare parts

1.6 Compliance

Quality is fundamental to the company's operation, working within the disciplines of ISO 13485.

This product features the CE mark, in compliance with the Medical Device Regulation 2017/745 Class I.

This product features the UKCA mark, in compliance with Part II UK MDR 2002 (as amended) Class I.

We are continuously working towards ensuring that the company's impact on the environment, locally and globally, is reduced to a minimum.

We only use REACH compliant materials and components.

We comply with the current environmental legislations WEEE and RoHS.

1.6.1 Product-specific standards

The wheelchair has been tested in accordance with EN 12183. It includes testing for flammability.



WARNING!

Indicates a hazardous situation that could result in serious injury or death if it is not avoided.

For further information about local standards and regulations, contact your local Invacare representative. See addresses at the end of this document.

1.7 Service Life

The expected service life of this product is five years when used daily and in accordance with the safety instructions, maintenance intervals and correct use, stated in this manual. The effective service life can vary according to frequency and intensity of use.

2 Safety

2.1 Safety Information

This section contains important safety information for the protection of the wheelchair user and assistant and for safe, trouble-free use of the wheelchair.



WARNING!

Risk of death or serious injury

In case of fire or smoke, wheelchair occupants are at particular risk of death or serious injury, when they are not able to move away from the source of fire or smoke. Lighted matches, lighter and cigarettes can cause an open flame in the wheelchair surroundings or on clothes.

- Avoid using or storing the wheelchair near open flames or combustible products.
- Do not smoke while using the wheelchair.



WARNING!

Risk of injury

- The wheelchair must be prescribed by a qualified person with knowledge about seating and positioning related to using a wheelchair.



WARNING!

Risk of accidents and serious injury

Accidents with resulting serious injury can occur if the wheelchair is improperly adjusted

- Contact your wheelchair provider in order to a qualified technician does the adjustments needed.



Invacare expects that the qualified technician is familiar with the product, with good technical knowledge to understand and follow the steps of the described instructions in this manual and equipped with proper tools.



WARNING!

Risk of overturning

The longitudinal position of the rear wheels axis of the wheelchair compared to the backrest position can affect its stability.

- A forwards position makes the wheelchair less stable and increase the risk of tipping backwards, but improves its maneuverability by a better grip position of the handrim and a short turning radius.
- Conversely, by moving the rear wheels axis backwards, the wheelchair is more stable and tilts less easily, but its maneuverability is reduced.
- Depending on the user's abilities and its particular safety limits, the decrease in stability can be compensated for by installing an anti-ti device.



WARNING!

Risk of falling

- Check that all parts are attached securely to the frame.
- Check that all wheels, knobs, screws and nuts are properly tightened.
- Check that all brakes and anti-tip devices are working correctly.
- Check that the castors and rear wheels are securely attached.
- Check that the wheelchair is equipped with anti-tip devices.
- Check the brakes are engaged before getting into or out of the chair.
- Never stand on the foot plates when getting into or out of the chair, because of the risk of tipping.
- Changing the thickness of seat and/or backrest cushions impacts the center of gravity of the chair, it increases the instability risk to the user if the set up is modified.
- Adjusting the seat angle can increase the risk of tipping over.
- The effectiveness of the brakes is reduced in wet and slippery conditions, as well as when on a slope.



WARNING!

Risk of foot injury

There is a risk that you could injured your feet when opening doors with foot plate.

- Do not open doors with parts of the wheelchair.



WARNING!

Risk of tipping/ falling when using tension adjustable backrest

- There is a risk of tipping and injury if the hook and loop straps on the backrest become too slack. Always check the tension. Also check that the rear wheels are adjusted to ensure that there is no risk of tipping.

**WARNING!****Risk of injury**

Never lift the wheelchair by the detachable armrests, footrests, back brace or by the adjustable push handles. See section "usage" for more information.

- The handrims may become hot due to friction, which may cause injury to your hands.
- When mounting options, etc. be careful not to trap your fingers.
- There is always an increased risk of trapping parts of your body when tilting the wheelchair's back and seat.
- The width of the seat must not be reduced too much, as this would increase the pressure from the armrests to the side of the pelvis.

**CAUTION!****Risk of burning**

The wheelchair components can heat up when exposed to external sources of heat.

- Do not expose the wheelchair to strong sunlight before use.
- Before usage, check all components that come into contact with your skin for their temperature.

**WARNING!****Risk of pressure sores and contracted posture**

- Do not seat in a tilted position for a long time. The seating position needs to be varied to avoid pressure sores.

**CAUTION!****Risk of injury**

- In case of pressure sore or injured skin, protect your injure to avoid a direct contact with the fabrics of the device. Refer to a healthcare professional for medical advices.

**NOTICE!**

When combining this product with another product, the restrictions of both products apply for the combination. E.g. the maximum load of the wheelchair of one product in the combination may be lower.

- Only use combinations allowed by Invacare. Contact your Invacare distributor for information.
- Before use, read the user manual of each product and check the restrictions. The full compliance with the information, instructions and recommendations contained in both user manuals is necessary for a safe use.

**NOTICE!****Risk when using an add-on to support or substitute propelling the wheelchair**

- For safety reasons, it must only be operated by persons who have the physical and mental ability to safely operate the wheelchair with the add-on attached to it in all possible situations (e.g. road traffic) and, in the event of the add-on failing to work or shutting down, are able to brake the wheelchair and stop safely. Any use contrary to the intended use involves a risk of injury.

At high speed you could lose control of your wheelchair and overturn.

- Drive carefully.
- Always adapt your speed and your driving style to the conditions (weather, surface, individual ability, etc.).
- Avoid collisions.

An add-on to support or to substitute propelling the wheelchair increases the strain on the wheelchair structure.

- After each use of an add-on, check the wheelchair for frame cracks or loose screwing.
- If any sign of fatigue on the wheelchair structure, stop using the wheelchair immediately and contact a qualified technician.

2.2 Safety information on electromagnetic interference (EMI)

This mobility device was successfully tested in accordance with International standards as to its compliance with Electromagnetic Interference (EMI) regulations. However, electromagnetic fields, such as those generated by radio and television transmitters, and cellular phones can influence the functions of powered mobility devices. Also, the electronics used in our mobility devices can generate a low level of electromagnetic interference, which however will remain within the tolerance permitted by law. For these reasons we ask you to please observe the following precautions:

**WARNING!****Risk of malfunction due to electromagnetic interference**

- Do not switch on or operate portable transceivers or communication devices (such as radio transceivers or cellular phones) when the mobility device is switched on.
- Avoid getting near strong radio and television transmitters.
- In case the mobility device moves unintentionally, switch it off immediately and report it to the manufacturer.
- Adding electrical options and other components or modifying the mobility device in any way can make it susceptible to electromagnetic interference. Keep in mind that there is no sure way to determine the effect such modifications will have on the overall immunity of the electronic system.

2.3 Labels and symbols on the product

2.3.1 Identification label

The identification label is attached to the frame of your wheelchair and gives the following information:



- A Manufacturer's address
- B EAN/HMI barcode
- C European conformity
- D United Kingdom conformity
- E Read user manual
- F Medical device
- G Maximum load of the wheelchair
- H UDI barcode
- I UDI (Unique Device Identifier)
- J Serial number
- K Reference number
- L Seat width
- M Product description
- N Date of manufacture

	Read user manual
	Indicates a hazardous situation that could result in serious injury or death if it is not avoided.

2.3.2 Posture belt information label

	The posture belt has the good length, when there's just sufficient space for a flat hand between body and belt.
--	---

2.3.3 Snap hook system labels

	Tie-down positions where the restraint system straps must be placed in case of transporting the occupied wheelchair in a motor vehicle. This symbol is only attached to the wheelchair when it is ordered with the transportation kit option.
--	---

	WARNING Symbol This wheelchair is not configured for passenger transport in a motor vehicle. This symbol is attached to the frame close to the identification label.
--	--

2.3.4 Symbols on Electrical Version

	Waste disposal and recycling information. See section "9 After use, page 36"
	CLASS II equipment
	Product with a thermal fuse
	Applied Part complying with the specified requirements for protection against electrical shock according to IEC60601-1
	Safety Isolation transformer, general

3 Product Overview

3.1 Product description

This is a passive wheelchair with seat and backrest tilting mechanism and swing-away, angle adjustable leg rests.



NOTICE!

The wheelchair is manufactured and configured individually to the specifications in the order. The specification must be performed by a healthcare professional according to the user's requirements and health condition.

- Consult a healthcare professional if you intend to adapt the wheelchair configuration.
- Any adaptation should be performed by a qualified technician.

3.2 Intended use

The wheelchair is intended to provide mobility to persons limited to a sitting position with a high level of dependency, who are sitting in the wheelchair for long periods of time and propelling the wheelchair occasionally.

The wheelchair may be used indoors and outdoors on level ground and accessible terrain (depending on the chosen size of front castors).

3.2.1 Intended users

The wheelchair is intended for persons, ages 12 and up (adolescents and adults). The weight of the wheelchair occupant should not exceed the maximum load of the wheelchair as stated in the Technical Data section and on the identification label.

The intended user is the wheelchair occupant and/or an assistant. The user should physically and mentally be able to use the wheelchair safely (e.g. to propel, steer, brake).

3.2.2 Indications

- Considerable to complete impairment of mobility due to structural and/or functional damage to the lower extremities.
- A steady upright sitting position is not possible due to disability.

3.2.3 Contra-indications

- A seat tilt is not suitable for users who are sensitive for increased blood pressure in the upper part of the body.

3.3 Main parts of the wheelchair

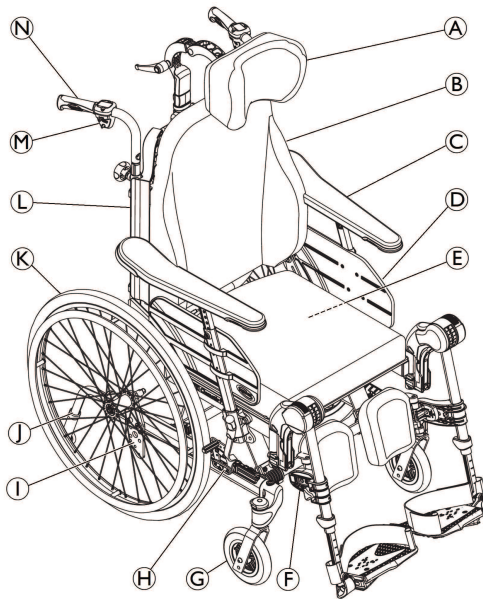

- Ⓐ Neckrest
- Ⓑ Backrest
- Ⓒ Armrest
- Ⓓ Seat
- Ⓔ Identification label and Electrical information label (if so equipped)
- Ⓕ Leg rests, swiveling
- Ⓖ Front castor
- Ⓗ Brake
- Ⓘ Rear wheel plate
- Ⓝ Anti-tip device
- Ⓚ Rear wheel with handrim
- Ⓛ Allen key for adjustment (on the back of the backrest cushion)
- Ⓜ Lever for backrest angle and seat tilt adjustment
- Ⓝ Push handle

 The equipment of your wheelchair may differ from the diagram as each wheelchair is manufactured individually to the specifications in the order.

 The wheelchair must always be equipped with seat cushion and armrest.

3.4 Parking brakes

The parking brakes are used to immobilize the wheelchair when it is stationary to prevent it from rolling away.



WARNING!

Risk of overturning if you brake sharply

If you engage the parking brakes while you are moving, the direction of movement can become uncontrollable and the wheelchair may stop suddenly, which can lead to a collision or to you falling out.

- Never engage the parking brakes while you are moving.



WARNING!

Risk due to wheelchair being out of control

- The parking brakes must be operated simultaneously.
- Do not engage the parking brakes to slow down the wheelchair.



WARNING!

Risk of overturning

The parking brakes will not operate correctly unless there is sufficient air in the tyres.

- Ensure the correct tyre pressure, for more information see 11.3 Tyres, page 40.



CAUTION!

Risk of pinching or crushing

There may be a very small gap between the rear wheel and the parking brake with the risk that you could trap your fingers.

- Keep your fingers away from movable parts when using the brake, always keep your hand on the brake lever.



The distance between the brake shoe and the tyre can be adjusted. The adjustment must be carried out by a qualified technician.

To operate the brake, refer to 6.2.1 Using the user operated brake, page 25.

3.5 Backrest

3.5.1 Adjusting the "Laguna" tension adjustable backrest



WARNING!

Risk of injury

The position of the head could cause neck and/or breathing problems for the user if the hook and loop straps come loose at the top of the backrest.

- Make sure that the hook and loop straps only has a minimum of 6 cm overlap distance. Press the hook and loop straps firmly together and make sure that they stay fixated.



WARNING!

Risk of pressure sores

When the backrest is in the most reclined position, there is a risk of pressure sores.

- Make sure that there are no pressure areas and monitor the user and make adjustments in order to avoid pressure sores.

**WARNING!****Risk of injury**

Too much slack on the hook and loop straps when using cover Lateral and neckrest bow/pole can cause pressure sores.

- Make sure that there is a space between the backrest and the neckrest bow/pole in order to avoid pressure sores.

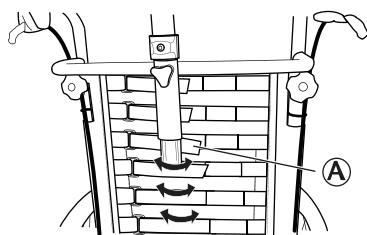

1. Adjust the shape of the “Laguna” tension adjustable backrest with the hook and loop straps A.

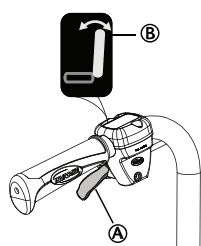
3.5.2 Adjusting the backrest angle

1. Use the yellow lever A marked with the yellow symbol B on the left hand side to angle the backrest.
2. Press upwards while you angle the backrest to the desired position.
3. Release the lever.

3.6 Tilting seat and backrest

The whole seat unit including the backrest can be tilted.

**WARNING!****Risk of fatal injury**

Increased blood pressure against the upper part of the body.

- All combinations of settings (like opened knee angle + full tilt and recline) where the lower extremities are positioned higher than the heart, have to be evaluated from a medical point of view. The position can be contraindicated for users who are sensitive for increased blood pressure in the upper part of the body.

**WARNING!****Risk of choking or breathing problems**

- The user might choke from eating or drinking when seated in a tilted or reclined position.
- The user must be seated in a raised position while eating or drinking.

**WARNING!****Risk of tipping**

The risk of tipping backwards increases when the wheelchair is tilted or reclined

- The user may slide out of the wheelchair even in a tilted or reclined position
- Always use an anti-tip device.
- Never leave the user at a flat or negative tilt angle without supervision.
- Use the posture belt.

**CAUTION!****Risk of injury**

The user must keep their head in an up-right position when the backrest is reclined, and/or the seat is tilted.

- The backrest must be equipped with a head support or a neck support.

**CAUTION!****Risk of trapping fingers**

- Be careful when adjusting the backrest angle so that the assistant or user do not trap fingers between the backrest and the armrest.

**CAUTION!****Pressure sores difficulties**

Tilting and reclining position combination are uncomfortable for certain users.

- Be careful when adjusting the tilt or recline angle, always start tilting the seat and reclining the backrest second.

To operate the tilt and recline adjustment, refer to paragraph Using the wheelchair, 6.3 Using the tilt and recline function, page 26.

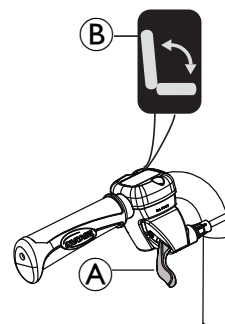
Carer-operated tilt adjustment

1. Use the green lever A with the green symbol B on the right hand side to tilt the seat unit (seat and backrest).
2. Press upwards while you tilt the seat unit to the desired position.
3. Release the lever.

Locking the tilt and/or backrest angle adjustment

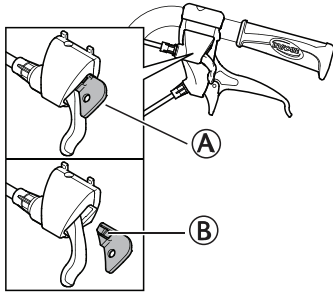

The locking device (A) allows you to set the tilting of the seat unit and/or the angling of the backrest to a fixed position.

1. Tilt and/or angle the seat and backrest to the desired position.
2. Insert the locking device (A).



The position is now set and cannot be changed.

To remove the locking device, press on the plastic peg (B) with a small object and pull outwards.

Electric tilt and backrest angle adjustment



WARNING! Risk of injury

If the wheelchair is used by users that are confused, restless, or with spasms:

- either lock the hand control functions;
- or ensure the hand control is out of reach.



WARNING! Risk of injury

When tilting the wheelchair, parts of the body can be squeezed between the armrest base and the rear wheel.

- Make sure that the distance between the armrest base and the rear wheel is always 25 mm or more.



CAUTION! Risk of damage to the product

- Make sure that the hand control is not unintentionally activated.
- Do not let children play with the hand control.
- If anything unusual is observed, such as unusual sounds or uneven running during operation, shut down the system.



NOTICE! Risk of malfunction

- Work on the hand control or other electric parts (motors etc.) should only be carried out by a qualified technician.

When activating the **On/Off** button, a short “beep” confirms that the hand control is activated. The hand control is active in 30 secs after last action, before it is automatically deactivated.



The hand control can also be manually deactivated by pressing the **On/Off** button.



The force needed to press the buttons on the hand control is 5 Nm (finger power).

Symbols on the hand control

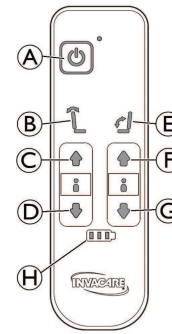

(A)	On/Off button
(B)	Backrest recline (yellow color on arrow and backrest)
(C)	Up button for backrest recline
(D)	Down button for backrest recline
(E)	Seat tilt (green color on arrow, backrest and seat)
(F)	Up button for seat tilt
(G)	Down button for seat tilt
(H)	Battery indicator

Backrest angle adjustment

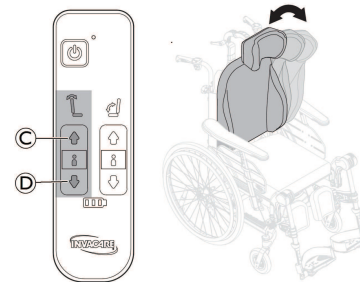

Adjust the angle of the backrest by using the yellow buttons on the left side of the hand control.

1. For forwards (up), press button (C).
2. For backwards (down), press button (D).

Seat tilt adjustment

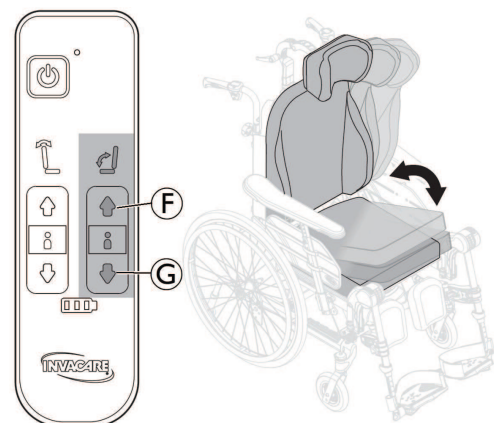

Tilt the seat unit (seat and backrest) by using the green buttons on the right side of the hand control.

1. For forwards (up), press button (F).
2. For backwards (down), press button (G).

**CAUTION!****Risk of trapping fingers**

Could result in minor injuries.

- The risk of trapping fingers, etc., is greater in electric adjustments than in user-operated adjustments.
- Bear in mind, for example, that a child may get hold of the control box, press the controls and get trapped, or trap the user.
- The hand control should only be used by authorised personnel.

Charging the battery**WARNING!****Risk of electrical shock**

- The user must not sit in the wheelchair while the battery is charging.

**NOTICE!****Risk of damage the battery**

- The battery must be charged 24 hours before using the system the first time.
- Unplug the mains cable after charging and before using the wheelchair.



The battery charger has different charging cables in order to adapt to different local electrical standards.



When the battery level is low (20%), the system beeps when it is in use.

Connect charger cable**CAUTION!****Damage to the cables**

- Do not sit in the wheelchair while charging the battery.

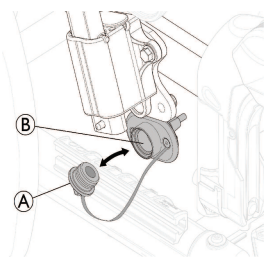

1. Previously remove the charger socket cap (A) out of its location.
2. Insert the charger magnetic plug into the charger socket (B) which is located under the armrest holder.
3. Connect the charger power cable into a wall socket.
4. Unplug the power cable first when the battery is fully charged.
5. Reinstall the charger socket cap (A) into its location.

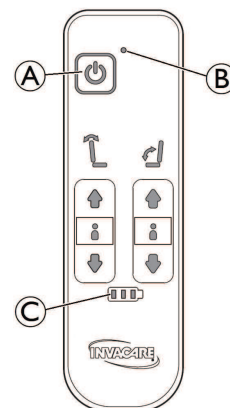
Hand control — battery indications

(A)		On/Off button
(B)	Green light	Hand control is activated
(C)	Green light 	Battery level is high (above 60%)
	Green light flashing 	Battery is charging (5 beeps indicate the battery is fully charged)
	Green light 	Battery level is 40% to 60%
	Green light 	Battery level is low, 20% to 40%
	Red light 	Battery level is very low (below 20%). The battery needs to be charged



In some case, after recharging the battery at a very low level, you may need to press (more than one second) on the **ON** button located on right side of the battery box, fixed under the seat plate, see 9.1.1 *Storage electrical version*, page 36.

Hand control — locking iRecline and tilt functions

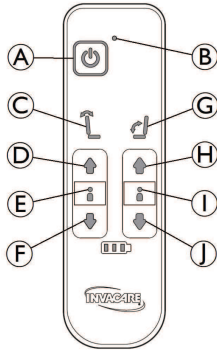

(A)	On/Off button	
(B)	Green light	Hand control is activated
(C)	Backrest recline	Yellow buttons
(D)	Up Button	
(E)	No light (recline not locked)	Red light (recline locked)
(F)	Down button	
(G)	Seat tilt	Green buttons
(H)	Up button	
(I)	No light (tilt not locked)	Red light (tilt locked)
(J)	Down button	

Lock / unlock recline function

- To lock the function, press simultaneously **Up** (D) and **Down** (F) buttons during three seconds.
- The backrest recline function is locked.
- Light (E) is red.
- To unlock the function, press simultaneously **Up** (D) and **Down** (F) buttons during three seconds.
- The backrest recline function is unlocked. Light (E) turn off.

Lock / unlock tilt function

- To lock the function, press simultaneously **Up** (H) and **Down** (J) buttons during three seconds.
- The seat tilt function is locked.
- Light (I) is red.
- To unlock the function, press simultaneously **Up** (H) and **Down** (J) buttons for three seconds.
- The backrest recline function is unlocked. Light (I) turned off.

 If the **Recline** (C) and/or **Tilt** (G) functions are locked before power button is **Off**, the lights (E) and/or (I) stays red after power button is **On** again.

3.7 Push handles/push bars

The following instructions and warnings are valid for all push handles and the push bar:

 Concerning the push handles/push bar for the bent backrest tubes follow the instructions for height adjustment of the push bar.

3.7.1 Adjusting the height of connected push handles

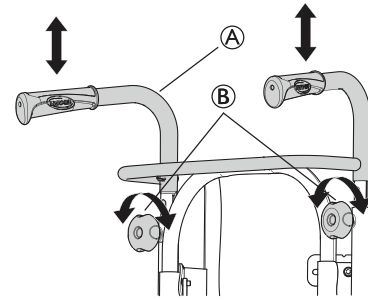

- Loosen the hand wheels (B).
- Adjust height of the push handles braced / push bar (A) by pulling the handles upwards or pushing them downwards.
- Adjust to the height that you require.
- Re-tighten the hand wheels.

 Make sure that the hand wheel for the push handle (A) fits the hole in the tubes. If the threaded tap of the hand wheel (B) is more than app. 2,5 mm visible, the position is wrong. Lower or raise the push handle to get the hand wheel in the correct position.

 The push bar/push handles brace (A) must not be pulled up so that it protrudes more than 19 cm over the top edge of the attachment.



CAUTION!

Risk of trapping fingers

- Do not trap your fingers between the push handles braced and the neckrest attachment. (If you have a tension adjustable backrest).

3.7.2 Adjusting the height of the push bar

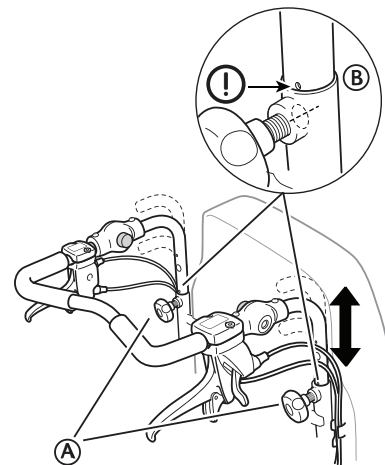

- Loosen the hand wheels (A).
- Adjust the handles to the required height position. There are two fixed positions available.
- Adjust to the height you require.
- Re-tighten the hand wheels.

**CAUTION!****Risk of injury**

The push bar can loosen from the attachments.

- Make sure that the marking **B** on the push bar tube is aligned with the backrest tube extremity.
- Check that the handwheels can be tightened properly, the screw of the handwheel should barely be visible. If the push bar is in the wrong position, you will not be able to properly tighten the handwheel.

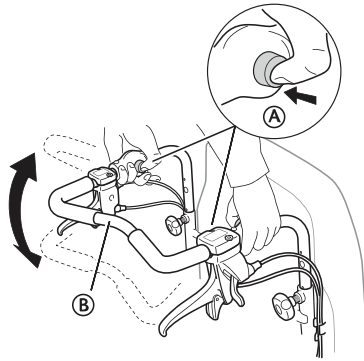
3.7.3 Adjusting the angle of the push bar

1. Press the buttons **A**.
2. Adjust the push bar **B** to the preferred angle.
3. Release the buttons **A**.



Move the push bar slightly in order for the buttons to lock into position.

**WARNING!****Risk of imbalance**

- Do not hang anything on the push bar, this could cause imbalance.

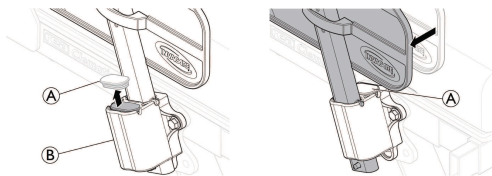
3.8 Seat adjustments**3.8.1 Adjusting the seat width (optional, 2 positions)**

1. Remove the armrest holder cap **A**.
2. Move the armrests sideways to the desired width into the armrest holder **B**.
3. Insert the armrest holder cap **A** in its new position.

**WARNING!****Risk of pinching**

- Be careful not to trap your fingers between the armrest side support and the armrest holder. See 5.5 *Inserting and removing the armrests*, page 23.

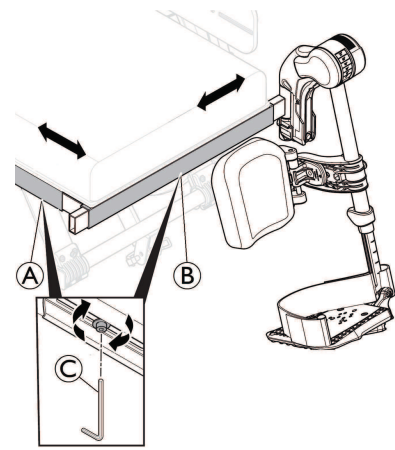
3.8.2 Adjusting the seat depth

1. Remove the seat cushion.
2. Loosen the screws **A** with an 5 mm Allen key.
3. Move the front edge of the seat forwards or backwards.
4. Re-tighten the screws **A** (5–6 Nm).
5. Put the seat cushion back.

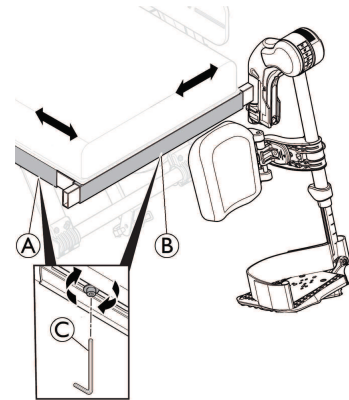
3.8.3 Adjusting the legrest width

1. Loosen the screws **B** with an 5 mm Allen key **C**
2. Move the lateral edge of the legrest sideways to the desired position.
3. Re-tighten the screws **B** (5–6 Nm).

3.8.4 Adjusting the seat cushion**WARNING!****Risk of falling**

Do not put the seat cushion too far from the front of the seat plate edge.

- The maximum safe distance between the front of the seat cushion and the seat plate edge is 2 cms (20 mm).

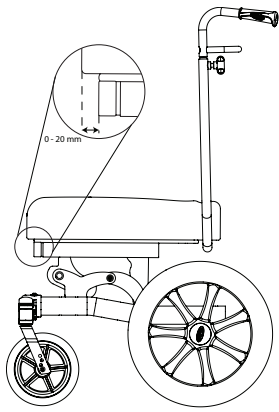

Place / remove the seat cushion

1. Position the front of the seat cushion aligned to the seat plate front edge.
2. Press the cushion, starting from the front to the back, to secure it properly along the full length (**NB**: Rear wheel size reduced in these illustrations for clarity purposes).

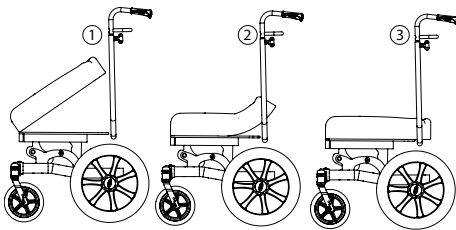

1. To remove the cushion, grab the cushion from the front and pull it upwards.

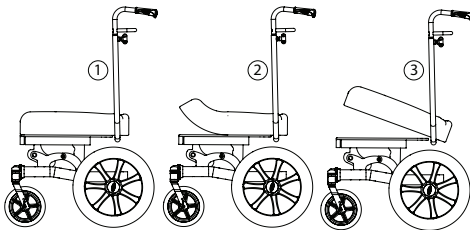

NOTICE!
 Risk of damage
 — Avoid removing the cushion from the back.
 — Grab it from the front and pull it upwards.

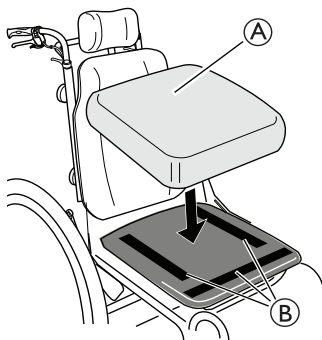

Depending on the cushion model, some seat cushions (A) can be secured with hook and loop straps (B) on the seat plate.

WARNING!
 Risk of seat cushion sliding
 — Make sure that the hook and loop straps are pressed firmly together and make sure that they stay fixated.

3.9 Leg rests

WARNING!
 Risk of injury
 — Never lift the wheelchair by the footrest supports or leg rests.

WARNING!
 Risk of pinching or crushing fingers
 There are swing mechanisms where you could trap your fingers.
 — Be careful when using, swinging, disassembling or adjusting these mechanisms.

NOTICE!
 Risk of damage to the leg rest mechanism
 — Do not place anything heavy, or let children sit on the leg rest.

3.9.1 Swing away leg rests

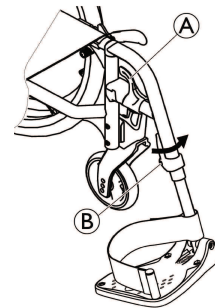

Swinging outwards

- Activate the release lever (A) and swing leg rests outside.

Swinging forwards

- Swing the leg rest forwards until it engages.

Unhinging

- Activate the release lever (A).
- Pull the leg rest upwards.

Hinging

- Hinge the leg rest on the front of the frame and swing it forwards until it engages.

3.9.2 Swing away, angle adjustable leg rests

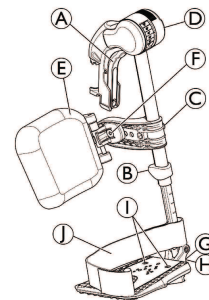

Swinging outwards

- Activate the release lever (A) and swing the leg rests outwards.

Swinging forwards

- Swing the leg rest forwards until it engages.

Unhinging

1. Activate the release lever **A**, swing the leg rest outwards.
2. Pull the leg rest upwards.

Hinging

- Push the leg rest down into its receiver and swing it forwards until it engages.

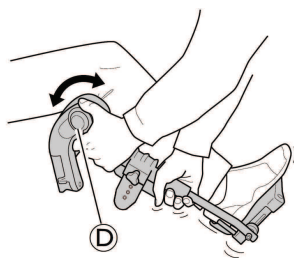
Adjusting angle

There are six preset positions available for angle adjustment.

- Rotate the knob **D** with one hand while supporting the leg rest with your other hand.
- When a suitable angle is obtained, let go off the knob and the leg rest will lock into the desired position.

Swinging calf pad and adjustments

- Swinging calf pad forwards (1) or backwards (2):

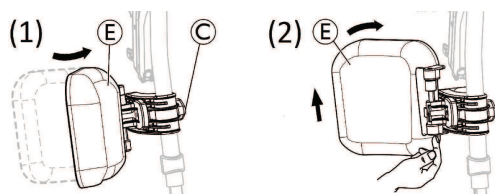

- Swing calf pad **E** forwards (1).
- Pull up the calf pad **E** and swing it backwards (2).

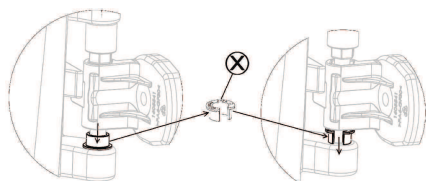
Locking the calf pad swing backwards:

1. Extract the grey spacer open ring **X** out of its location.
2. Reverse the grey spacer open ring.
3. Insert the grey spacer open ring **X** as shown on the right side of the diagram.

 Reverse this procedure to unlocking the calf pad swing backwards.

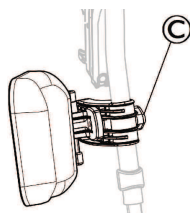
Adjusting height of calf pad:

1. Loosen knob **C**.
2. Adjust to the desired height and firmly tighten the knob.

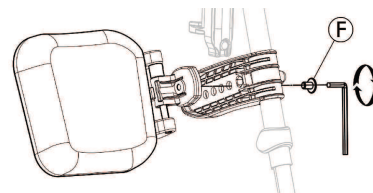
Adjusting depth of calf pad

The calf pad has four depth adjustment options:

1. Remove the fixing screw **F** with 5 mm Allen key.
2. Adjust to one of the four positions and firmly tighten the fixing screw **F** (3–5 Nm).

Adjusting foot plate

There are three different fold-up foot plates available.

- Standard height-adjustable foot plates:

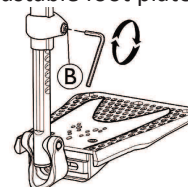

1. Loose the fixing screw **B** with 5 mm Allen key.
2. Adjust the height and let the screw catch one of the recesses on the foot plate tube.
3. Tighten the fixing screw **B** (3–5 Nm) in the desired position.

 The distance between the lowest part of the footrest and the ground must be at least 50 mm.

- Depth-, Angle- (1) and Width- (2) adjustable foot plates:

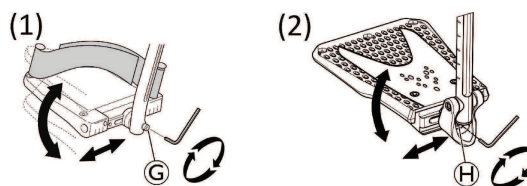

1. Loosen the fixing screw **G** or **H** with 5 mm Allen key.
2. Adjust the depth and angle positions and firmly tighten the fixing screw **G** (12 Nm) or **H** (8–9 Nm) in the desired position.

Width-adjustable foot plates (2):

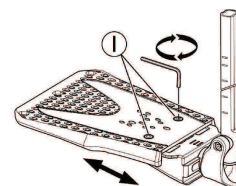

1. Loosen the two fixing screws **I** with 5 mm Allen key.
2. Adjust the width position and firmly tighten the two fixing screws **I** (3–5 Nm) in the desired position.

We recommend that foot plate adjustments are carried out by a qualified technician.

 To ensure a good position of the feet, two types of straps can be provided; the heel strap (serial) and the calf strap (optional) attached to the leg rest support. Both are adjustable by hook and loop fasteners or sliding buckle.

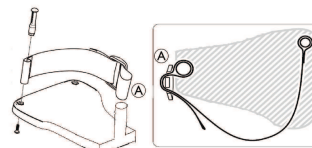

The plastic buckle must be fitted facing outwards and as close as possible to the tube of the footplate (A).

3.10 Anti-tip device

An anti-tip device prevents the wheelchair from tipping backwards.



WARNING!

Risk of overturning

Anti-tip devices that are incorrectly set or no longer working can lead to overturning.

- Always check that the anti-tip device is working before using the wheelchair and have it set or readjusted by a qualified technician when required.



WARNING!

Risk of overturning

On uneven or soft ground, the anti-tip device can sink into potholes or directly into the ground, thereby curtailing or eliminating its safety function.

- Only use the anti-tip device when travelling on even and firm ground.

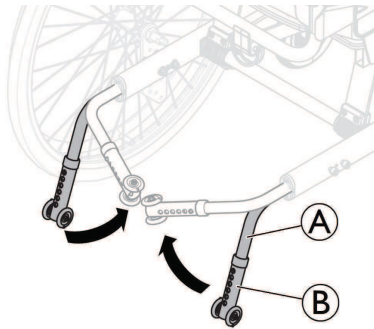

3.10.1 Activating the anti-tip device

1. Pull slightly the anti-tip device (A) backwards and swivel it downwards (90°), until it engages.
2. Repeat the procedure on the opposite side.



WARNING!

Risk of tipping

An activated anti-tip device can catch when negotiating a step or an edge.

- Always deactivate the anti-tip device before driving over a step or kerb.

3.10.2 Deactivating the anti-tip device

1. For transport position, pull slightly the anti-tip device (A) backwards and swivel it inwards (90°), until it engages.
2. Repeat the procedure on the opposite side.



WARNING!

Risk of overturning

- Always advise the user if you deactivate the anti-tip device.



WARNING!

Risk of tipping

The wheelchair can tip backwards if the anti-tip device are not activated.

- Do not forget to activate the anti-tip device after transport.

3.10.3 Setting the height

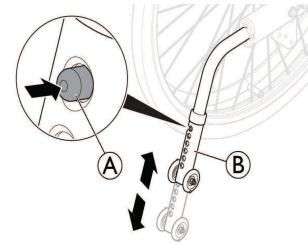

1. For height adjustment, press the spring button (A).
2. Adjust the anti-tip device tube (B) to the desired height.
3. Ensure that the spring button (A) protrudes fully through anti-tip device tube (B), after adjustment.

Invacare recommends that anti-tip device height adjustment is carried out by a qualified technician.



The anti-tip device has six possible height positions. Adjust the height from floor at the bottom of anti-tip device between 15 mm (Minimum) to 40 mm (Maximum).



This adjustment is required with reference to the position and diameter of the rear wheel as well as the user conditions and his particular safety limits.



Make sure that the anti-tip device is fitted correctly on each side. The spring button (A) must protrude fully through their respective hole.

3.10.4 Using the anti-tip device as a tipping aid

With the anti-tip device, an assistant can tip the wheelchair more easily, in order to navigate steps for example.



1. If required, activate the anti-tip device (see 3.10.1 *Activating the anti-tip device, page 16*).
2. If necessary, adjust the height of the anti-tip device to cross the obstacle.
3. Hold the wheelchair by the push handles.
4. Press the anti-tip device with your foot and hold the wheelchair in the tipped position until you have overcome the obstacle.





After crossing the obstacle, if necessary readjust the anti-tip device height to its initial position, this is carried out by the assistant.

4 Options

4.1 Headrest and neckrest

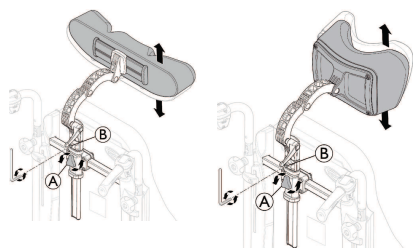
4.1.1 Adjusting the headrest height



 The height and the removal are operated by the handwheel. The bar is equipped with an adjustable stop block.

1. Loosen the screw in the stop block (B) with 5 mm Allen key.
2. Loosen the hand wheel (A).
3. Adjust the headrest to the desired position.
4. Re-tighten the hand wheel (A).
5. Slide the stop block (B) down to the top of the headrest attachment.
6. Re-tighten the screw (5–6 Nm).

 It is now possible to remove the headrest and reinsert it in the desired position without further adjustments.

4.1.2 Adjusting the headrest depth and angle

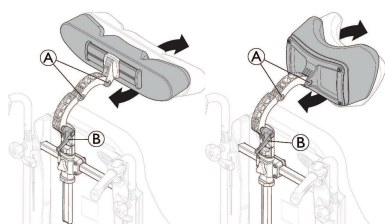

1. Loosen the handle (B).
2. Loosen the screws (A) with 5 mm Allen key.
3. Adjust the depth and angle of the headrest/neckrest.
4. Re-tighten the handle and the two screws (5–6 Nm).

4.1.3 Adjusting the headrest width

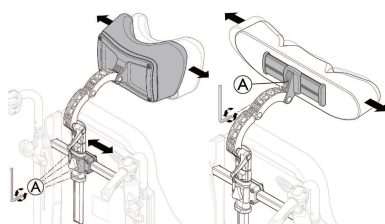

1. Loosen the four screws (A) with 5 mm Allen key.
2. Slide the bracket to adjust the width of the neckrest/headrest.
3. Re-tighten the four screws (5–6 Nm).
4. The headrest can be additionally adjusted in width, loosen the screw (A) with 5 mm Allen key. The headrest can be additionally adjusted in width, loosen the screw (A) with 5 mm Allen key.
5. The headrest can be additionally adjusted in width, loosen the screw (A) with 5 mm Allen key.
6. Re-tighten the screw (A) (5–6 Nm).

4.2 Hemiplegic armrest

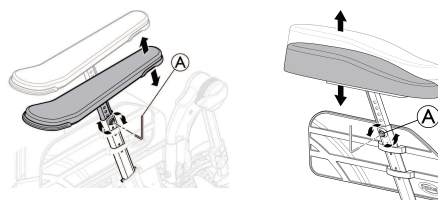

1. Loosen the screw (A) with 5 mm Allen key..
2. Remove the original armrest.
3. Mount the hemiplegic armrest (C) in the armrest pole.
4. Re-tighten the screw (A).

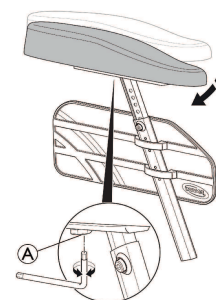

5. The hemiplegic armrest can be adjusted in angle. The resistance can be increased/ decreased by adjusting the screw (A).

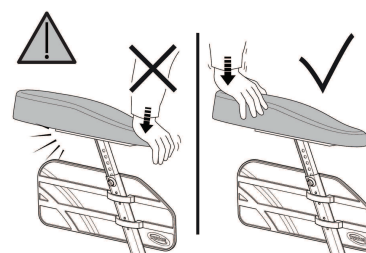

WARNING!

Risk of damage

Damage on the armrest

- Do not put pressure on the front of the armrest, as this could cause damage on the armrest attachment.

4.3 Abduction cushion

1. The height adjustment and removal is operated by the handwheel (A).

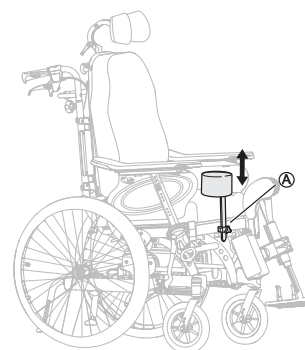

2. The depth is adjusted in a forward or backward position. Loosen handwheel (A) and turn.

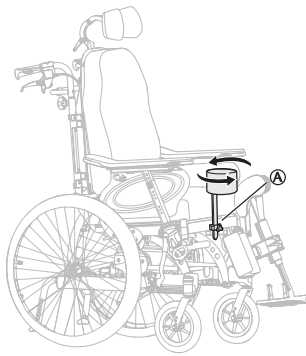

4.4 Trunk support with fixed arm or swing-away arm

Trunk supports can be adjusted (height, depth and sideways).



WARNING!

Risk of trapping

- Be careful not to trap your arm between trunk support and armrest when changing the backrest angle.

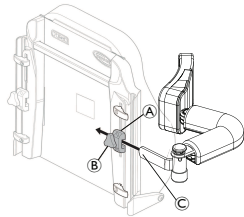

5 mm Allen key



The holder © is dedicated for the "swing-away" trunk support only.

4.4.1 Adjusting the fixed arm

Height adjustment

1. Adjust the height by first loosening the screw / screws (A).
2. Move the attachment (B) upwards or downwards.
3. Re-tighten the screw / screws.

Sideways adjustment

1. Loosen the knob (C) to adjust the trunk supports sideways.
2. Move the support sideways to the required position.
3. Re-tighten the knob (C).

Depth adjustment — fixed cushion

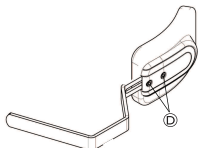

5 mm Allen key

1. Adjust the depth of the trunk supports by loosening the screws (D) with an Allen key.
2. Move the trunk support forwards or backwards.
3. Re-tighten the screws.
4. Remove the trunk support by loosening knob (C) and pull the trunk support sideways and outwards.

4.4.2 Trunk swing-away support



The holder © for the "swing-away" lateral trunk support is placed in the attachment (A) on the backrest.

1. Loosen the knob (B).
2. Place the lateral trunk support (C).
3. Re-tighten the knob.

Adjusting the angle of lateral trunk support

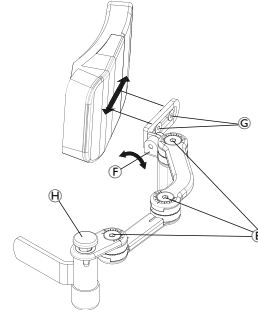

(E) 5mm Allen key

(G) 4mm Allen key

1. Lateral trunk arms can be adjusted by loosening screws (E).
2. The pad orientation can be adjusted by loosening the screw (F).
3. The depth position of the pad can be adjusted by loosening or changing the screw position (G).
4. When the required position is achieved, re-tighten the screws.



The swing-away lateral trunk support can be turned sideways by push green button (H).



CAUTION!

Risk of pinching

- The cover on the trunk support arm must always be on when the chair is in use.

4.5 Adjusting the drip stand



WARNING!

Risk of tipping / injury

- Max. load on the drip stand: 4 kg (2 x 2 kg)



The rod of the drip stand must always be placed in a vertical position, i.e. in a 90 degree angle to the ground, no matter the position of the backrest or the wheelchair.

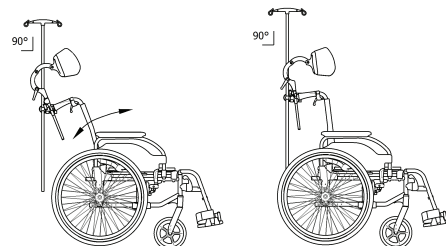

4.5.1 Drip stand height

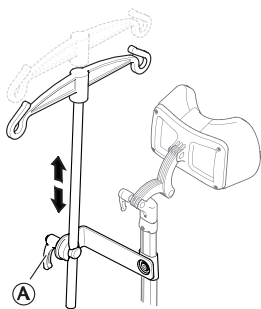

1. Loosen the lever (A).
2. Firmly tighten the lever (A).
3. Adjust the drip stand to the desired height.

4.5.2 Drip stand angle

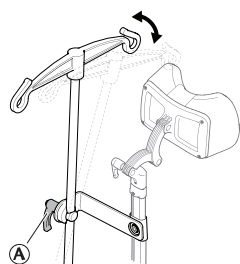

1. Loosen the lever (A).
2. Adjust to the desired angle.
3. Firmly tighten the lever (A).

4.6 Table trays



WARNING!

Risk of falling / injury

- The table must never be used as a replacement for the posture belt.



WARNING!

Risk of tipping / injury

- Max load on the table: 8 kg



CAUTION!

Risk of discomfort / minor bruises

- Make sure that the elbows of the user are placed on the table when pushing the wheelchair. If the elbows protrude from the table while pushing the wheelchair, there is a risk of discomfort or minor bruises.

The table tray can be adjusted both in depth and width, the following sections will show the different possibilities.

4.6.1 Adjusting the depth of the table tray

1. Open the safety lock for the depth adjustment (A).

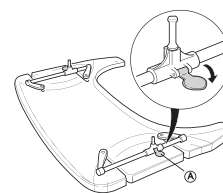

2. Adjust the table holders (B) forwards or backwards to adjust to the required depth.

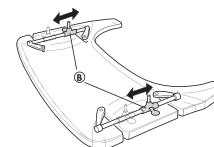

3. Close the table lock (A) again in order to lock the depth position.

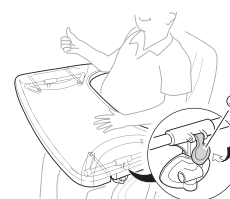

CAUTION!

Risk of discomfort / insecurity

The table is not in a fixed position.

- Make sure to engage the table lock again after adjusting the depth of the table.



CAUTION!

Risk of discomfort

- When adjusting the depth of the table, make sure not to squeeze the stomach of the user.

4.6.2 Locking the table tray





WARNING!

Risk of injury

The user is locked in a fixed position and can not be removed from the wheelchair without unlocking the table.

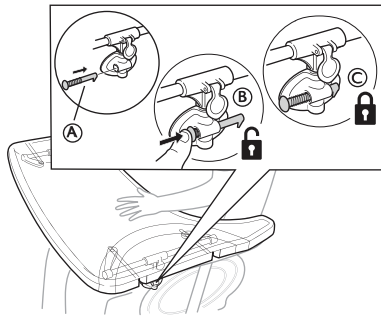
- The use of locking device for table tray must be prescribed by authorized personnel.



1. Place the locking pin (A) in the table attachment.
2. Press the locking (A) inwards to unlock the table (B).
 Keep pressing the locking pin inwards in order to keep the table in an unlocked position.
3. Release the locking pin (A) to lock the position of the table (C).

4.6.3 Swing away table

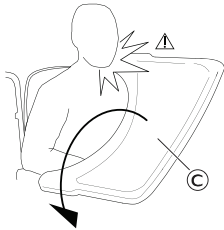

WARNING!

Risk of injury / bruises

- Take care not to hit the user while swinging the table.



WARNING!

Risk of table tipping forward

- Do not adjust the depth of the table too far forward, due to the risk of tipping the table when adding weight on it.

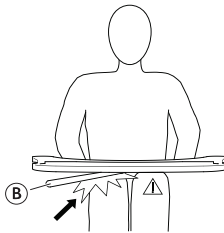

CAUTION!

Risk of discomfort / minor bruises

- Make sure that the user has enough space for the legs. The table tube must not rest on the legs of the user.

Depth adjustment

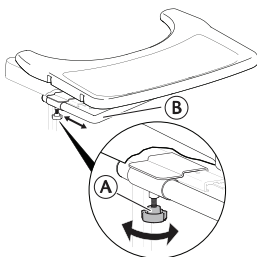

1. Loosen the handwheel (A).
2. Adjust the table in depth with the table tube (B).
3. Re-tighten the handwheel (A).

Swing away function

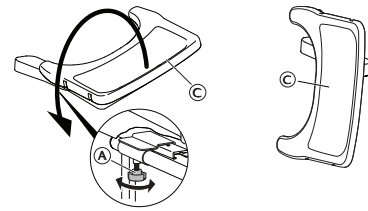

1. Loosen the handwheel (A).
2. Swing the table tray (C) sideways.
3. Re-tighten the handwheel (A).

4.6.4 Adding table tray cushions

A cushion for the table tray can be placed on the table tray in order to have a softer surface for the arms and elbows.

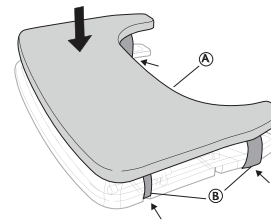

Place the cushion for the table tray (A) on the table and place the attachment straps (B) around the table.

4.6.5 Adding elbow cushions

The table tray can be equipped with cushions for the elbows, in order to have a softer surface for the elbows.

1. Remove the protection paper (A) from the elbow pads.

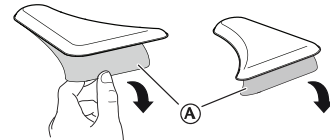

2. Place the elbow pads (B) on the table.

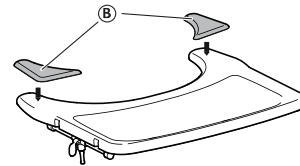

4.7 Half tray



WARNING!

Risk of falling / injury

- The half tray must never be used as a replacement for the posture belt.



WARNING!

Risk of tipping / injury

- Max load on the tip of the widest part of the half tray: 1.5 kg

**CAUTION!****Risk of discomfort / minor bruises**

- Make sure that the elbow of the user is placed on the half tray when propelling the wheelchair. If the elbow protrudes from the wheelchair while propelling the wheelchair, there is a risk of discomfort or minor bruises.

**CAUTION!****Risk of pinching fingers**

- There is a mechanism below the half tray where you could trap your fingers.
- Be careful when adjusting the tray or when using the swing-away function.

**CAUTION!****Risk of pinching or minor cuts**

- Do not transfer from the wheelchair when the half tray is in horizontal position.

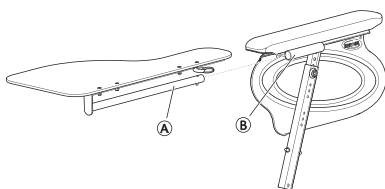

The half tray can be adjusted in width and swung away.

4.7.1 Mounting the half tray

1. Insert the tube of the half tray (A) into the attachment (B) under the arm pad.

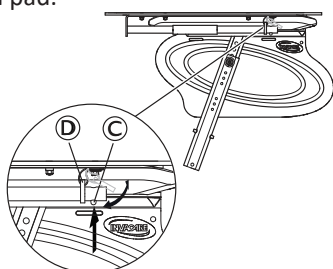

2. Push on the push pin (C) and insert the ring (D) on the tube (A).
3. Release the push pin (C).

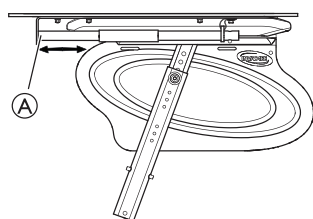
4.7.2 Adjusting the half tray

1. Slide the half tray (A) forwards or backwards to adjust to the required depth.

**CAUTION!****Risk of discomfort**

- When adjusting the depth of the half tray, do not squeeze the user's stomach.

4.7.3 Adding a half tray cushion

A cushion for the half tray can be placed on the half tray in order to have a softer surface for the arms and elbows.

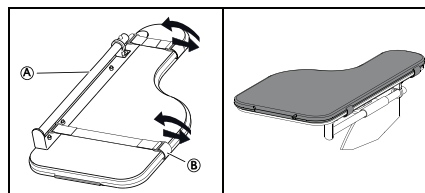

1. Place the cushion for the half tray (A) on the tray.
2. Place the attachment straps (B) into the plastic buckle and around the half tray (A).

4.8 Posture belt

The wheelchair can be equipped with a posture belt. It prevents the user from sliding downward in the wheelchair or from falling out of the wheelchair. The posture belt is not a positioning device.

**WARNING!****Risk of serious injury / strangulation**

A loose belt can cause the user to slip down and create a risk of strangulation.

- The posture belt should be mounted by a qualified technician and fitted by a healthcare professional.
- Always make sure that the posture belt is tightly fitted across the lower pelvis.
- Each time the posture belt is used, check if it fits properly. Changing the seat and/or backrest angle, the cushion and even your clothes influence the fit of the belt.

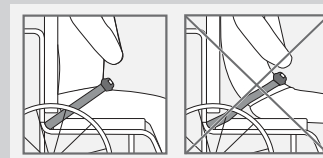
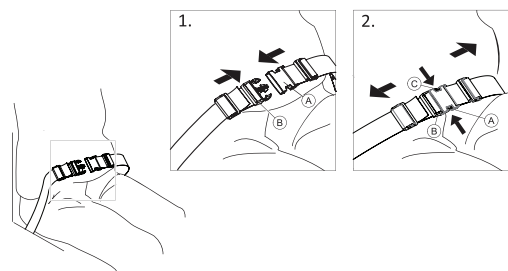
**4.8.1 Closing and opening the posture belt**

Ensure that you are sitting fully back in the seat and that the pelvis is as upright and symmetrical as possible.

1. To close, push the catch (A) into the buckle clasp (B).
2. To open, push the PRESS button (C) and pull the catch (A) out of the buckle clasp (B).

4.8.2 Adjusting the length of the posture belt

 The posture belt has the good length, when there's just sufficient space for a flat hand between body and belt.

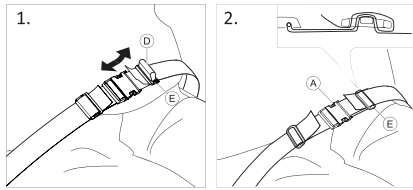

1. Shorten or extend the loop **D** as required.
2. Thread loop **D** through catch **A** and plastic buckle **E** until the loop is flat.
3. Ensure loop **D** is perfectly fitted in plastic buckle **E**.
4. Secure adjustment with the strap extremity fitted in the buckle **E**.



WARNING!

Risk of sliding and strangulation / Risk of falling

Do the adjustments on both sides equally, so that the buckle clasp remains in a central position.

- Ensure that both strap extremities are threaded two times into the buckle **E** to avoid the belt from loosening.
- Make sure that the belts do not get caught in the spokes of a rear wheel.

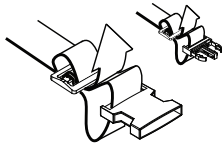

4.8.3 Posture belt mounting

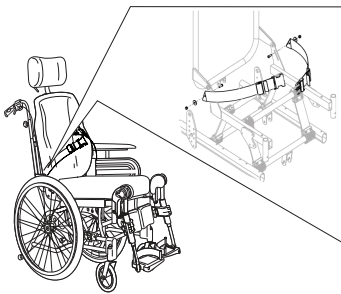

The posture belt **B** is mounted on the backrest brackets **A**.

4.9 Attachment when using positioning belt



CAUTION!

Risk of sliding

- The belt must be placed tight to the body.
- Our wheelchairs must always be used with a seat cushion. If the length of the belt has been adjusted to fit one type of seat cushion height, it is important that this cushion is used. If the seat cushion is replaced, the length of the belt needs to be adjusted.
- The seat must be positioned flat or tilted backwards if the user is left alone unattended.



Positioning belts which are CE-marked for the purpose of using on wheelchairs, can be mounted on the chair with preserved CE-marking. The positioning belt should be fitted by a healthcare professional and be mounted by a qualified technician.

For more information, see 7.4 *Transporting the occupied wheelchair in a vehicle*, page 30.



The purpose of using a belt for positional, is to position the user and to give them a better posture.



CAUTION!

Risk of sliding

- If you have a very low seat height and / or use your feet to maneuver the wheelchair, the legrests can be removed. If so, be aware of the sliding risk!

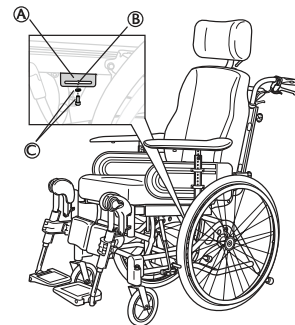

1. Loosen and remove the screw and the washer **C** for the legrest attachment.
2. Place the attachment **A** on the frame as shown on the picture.
3. Adjust the attachment to the required position.
4. Use the screw and the washer **C** to fixate the attachment **A** and tighten the screw.



The positioning belt should be placed in the slot **B** on the attachment **A**.

5 Setup

5.1 Safety information



CAUTION!
Risk of injury

- Before using the wheelchair, check its general condition and its main functions. See 2.1 *Safety Information, page 5*

Your authorized provider will supply your wheelchair ready for use. Your provider will explain the main functions and ensure that the wheelchair meets your needs and requirements.

Adjustments of the axle position and the castor supporters must be carried out by a qualified technician.

5.2 Delivery check

Any transport damage must be reported immediately to the transport company. Remember to keep the packaging until the transport company has checked the goods and a settlement has been reached.

5.3 Assembly

When you receive your wheelchair, you either install the backrest, neckrest, front and rear wheels or, on some models, fold up the backrest. You also have to install the armrests and leg rests on the wheelchair.

The assembly is simple and does not require any tools. Follow the instructions in 3 *Product Overview, page 7* or in the following paragraphs.

5.4 Installing the backrest



Be careful not to pinch the cables when raising the backrest.



WARNING!
Safety Risk

The wheelchair may collapse.

- Always reinsert and fasten the safety pin with the safety shackle ① when it has been removed.
- Check that the lock shackle / loop is securely locked.

5.4.1 Installing the backrest — gas piston

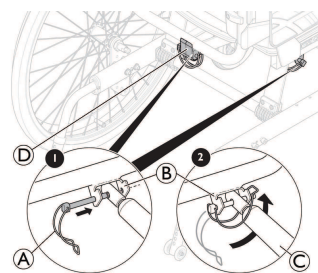

1. Raise the backrest to an upward position.
2. Attach the gas piston ③ to the attachment ② and plastic guide-block ④.
3. Insert the safety pin with the safety shackle A in the hole in the attachment ②.
4. Lock the safety shackle ① by folding in under the attachment ② and secure the loop on the other side.

5.4.2 Installing the safety shackle — electrical piston

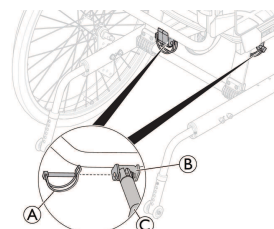

1. Raise the backrest to an upward position.
2. Attach the piston rod ③ to the attachment ②.
3. Insert the safety pin ① in the hole of the attachment ②.
4. Lock the safety pin.



WARNING!
Electrical version

The backrest may come loose if the piston rod is accidentally detached from its housing.

- Before attaching the piston to the backrest, turn the piston rod ③ clockwise to its maximum position.
- When aligning the holes, only turn the piston rod ③ to a maximum a half counterclockwise turn.

5.5 Inserting and removing the armrests



WARNING!
Risk of pinching

- Be aware of the pinching risk due to the small distance between the armrest holder and the rear wheel when tilting or propelling the wheelchair.

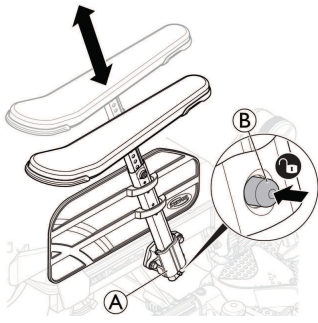

1. Previously press and maintain the locking mechanism ⑥ before inserting the armrest.
2. Place the armrest in the armrest holder ⑤.
3. Press the armrests downwards until that the armrests are securely in place.

 The armrests have a locking mechanism to prevent involuntary movement or detachment.

4. Press the locking mechanism ⑥ to release before removing or adjusting the armrest.

5.6 Adjusting the armrest height

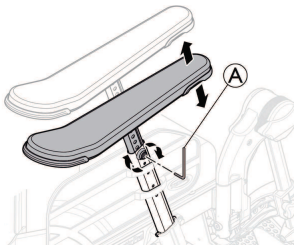

1. Adjust the height of the armrests by turning the screw or the hand wheel ⑤ depending on which type of armrest you have chosen.
2. Set the required height.
3. Re-tighten the screw / hand wheel.



CAUTION!
Risk of trapping fingers

— Be careful not to trap your fingers between the armrest / side support pad and the armrest holder when adjusting the armrest height.



Using low armrests, or adjusting the armrests in low heights, may cause conflicts with the rear wheels when tilting the chair.

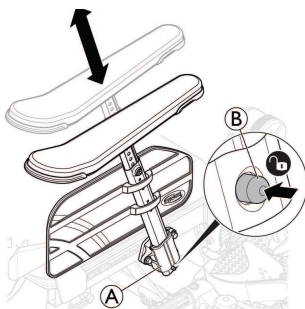

The armrests have a locking mechanism to prevent involuntary movement or detachment. Press the locking mechanism ⑥ on the armrest to release before inserting, removing or adjusting the armrest.

5.7 Adjusting the armrest/side rest depth

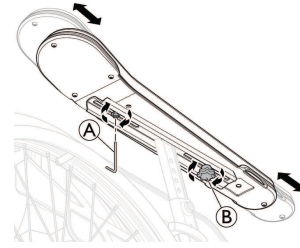

1. Loosen the handwheel ⑥.
2. Set the pad and or the side rest in the required position.
3. Re-tighten the screw / handwheel.
4. You can tighten the screw ⑤ to fix the depth.



CAUTION!
Risk of poor adjustment

— There must not be any pressure on the armrest while adjusting the handwheel or the screw.

5.8 Installing and removing rear wheels



WARNING!
Risk of overturning

If the removable axle of a rear wheel is not fully engaged, the wheel can become loose during use. This can lead to overturning.
— Always ensure that the removable axles are fully engaged whenever you install a wheel.



WARNING!
Risk of injury

— Check that the rear wheel is securely locked in position. It should not be possible to remove the wheels when the quick-release button ⑤ is inactivated.

Self Propulsion

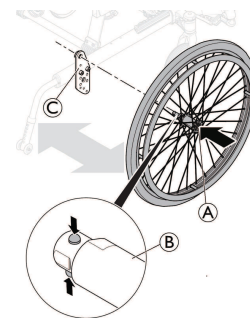

Transit Version

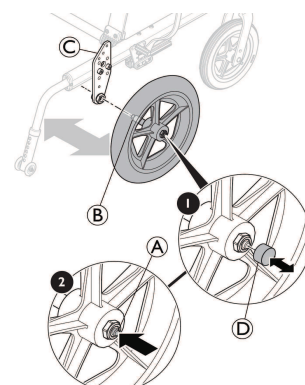

Installing the rear wheels

1. Release the brakes.
2. With one hand, hold the wheelchair upright.
3. With the other, hold the wheel through the external spoke rim around the wheel hub.
4. Using your thumb, press the quick-release button (A) and hold it down.
5. Push the rear wheel axle (B) into the adapter sleeve (C) up to the stop.
6. Release the quick-release button and make sure that the wheel is secure.
7. For Transit version, insert the quick-release cap (D) on the quick-release button.

Removing the rear wheels

1. Release the brakes.
2. With one hand, hold the wheelchair upright.
3. For Transit version, remove the quick-release cap (D) of the quick-release button (B).
4. With the other, hold the wheel through the external spoke rim around the wheel hub.
5. Using your thumb, press the quick-release button (A). Keep it pressed and pull the wheel out of the adapter sleeve (C).

5.9 Angle adjustable leg rests

To install or remove the swing away, angle adjustable leg rest, see 3.9.2 *Swing away, angle adjustable leg rests, page 14*.

5.10 Fixed leg rests

To install or remove the swing away, fixed leg rest, see 3.9.2 *Swing away, angle adjustable leg rests, page 14*.

5.11 Mounting the table tray

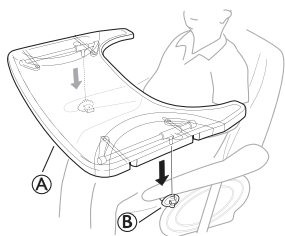

1. Mount the table tray (A) in the table tray attachments (B).

6 Using the wheelchair

6.1 General warnings — usage



WARNING!

Risk of tipping

The user can fall off the wheelchair when using their feet to maneuver the wheelchair.

- When you use your feet to maneuver the wheelchair, be aware that the centre of gravity is shifted forward. This changes the stability of the wheelchair.



CAUTION!

Risk of sliding

- The seat must be positioned flat or tilted backwards if the user is left alone unattended.



CAUTION!

Risk of sliding

- If you have a very low seat height and / or use your feet to maneuver the wheelchair, the legrests can be removed. If so, be aware of the sliding risk!

6.2 Brakes

6.2.1 Using the user operated brake

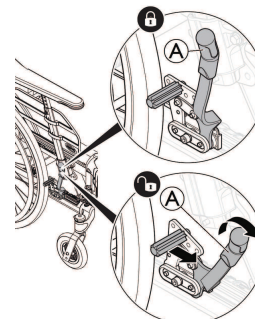

Start by checking that the tyres have the correct air pressure (printed on the side of each tyre).



The user brake is to be used when the chair is not moving, and is not intended for reducing speed when the chair is moving.

1. To engage the brake, move the lever (A) towards the rear (towards you).
2. To disengage the brakes, move the lever (A) forwards.



CAUTION!

Risk of trapping fingers

- Be careful not to trap your fingers between the brake shoe and rear wheel.

6.2.2 Using the foot operated brake

The Transit version is designed to be driven only by the attendant. To facilitate sideways transfers and save space, the wheelchair is equipped with rear wheels of 305 mm (12").



The distance between the brake shoe and the tyre can be adjusted. The adjustment must be carried out by a qualified technician.

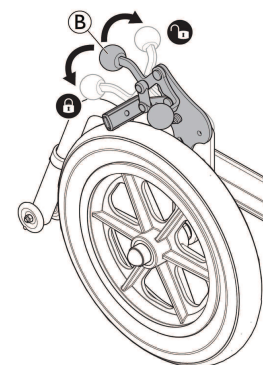

1. To engage the brake, push the brake lever (B) downwards as far as possible.
2. To disengage the brake, pull or push the brake lever (B) upwards.

6.2.3 Using the one arm brake

The wheelchair can be equipped with a one arm brake instead of the standard user operated brake. The one arm brake is operated in the same way as the standard user operated brake, the difference is that the brake handle brakes both wheels at the same time. The one arm brake is available both for the right and the left side of the wheelchair .

6.2.4 Using the carer-operated brake



WARNING!

Risk of reduced brake effect

- Incorrect setting or use of the brake reduces the braking effect.

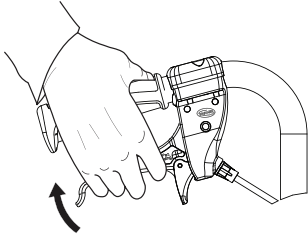

1. Braking when moving: squeeze both brake handles upwards, and the brake will be applied.

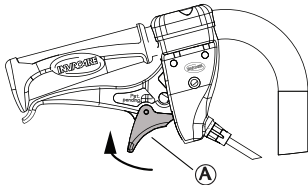

2. Locking the brakes: squeeze the handle and move the lock catch (A) upwards.
3. Release the handle.

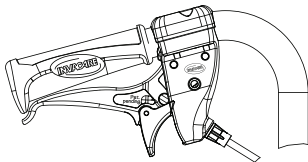

4. Releasing the brakes: squeeze the handle and the lock catch will release automatically.



If the brake effect is poor or reduced, contact your authorized provider.

6.3 Using the tilt and recline function

To ensure a good positioning, follow these steps when using both the tilt and the recline function. See 3.6 *Tilting seat and backrest*, page 9 for instruction about how to operate the tilt and/or the recline function.

6.3.1 Tilting / reclining from an upright position

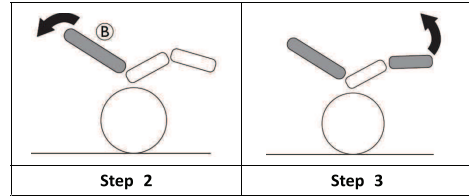
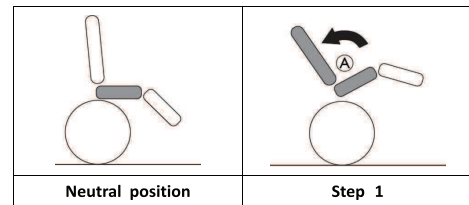

1. Tilt the chair.
 - This enables the user to slide to the rear and supports a neutral pelvis position (A).
2. Recline the backrest
 - The weight will now shift to the back and enable a good posture, as the bottom has slid into a rear position (B).
3. Angle the leg rests.



CAUTION!

Discomfort for the user

The pelvis will be strained and the user can slide downwards in the chair.

- Ensure that the backside of the thighs (hamstrings) are in a relaxed neutral position when angling the leg rests.

6.3.2 Rising from a tilted and reclined position

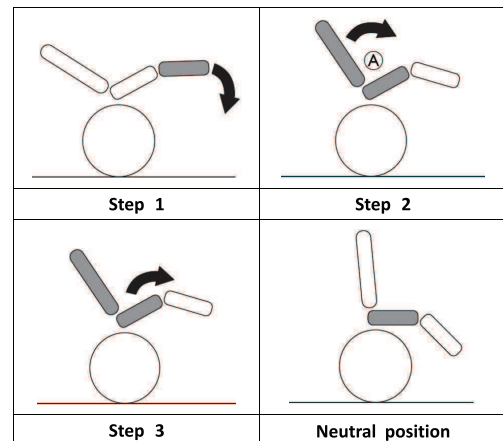

1. Fold down the leg rests.
2. Raise the backrest from the reclined position.
 - Raising the backrest before the tilt, preserves the neutral pelvis position (A).
3. Raise the tilted position.

6.4 Move to and from the wheelchair



WARNING!

Risk of overturning

There is a high risk of overturning during the transfer.

- Only get in and out without assistance if you are physically able to do so.
- When transferring, position yourself as far back as possible in the seat. This will prevent damaged upholstery and the possibility of the wheelchair tipping forward.
- Make sure that both castors are facing straight to the front.



WARNING!

Risk of overturning

The wheelchair could tip forwards if you stand on the footrest.

- Never stand on the footrest when getting in and out.



CAUTION!

If you disengage or damage the brakes the wheelchair could roll away out of control.

- Do not support yourself on the brakes when getting in and out.



NOTICE!

The mudguards and armrests could become damaged.

- Never sit on the mudguards or armrests when getting in and out.

1. Propel the wheelchair as near as possible to the seat that you want to move to.
2. Engage the parking brakes.
3. Remove the armrests or move them upwards out of the way.
4. Detach the leg rests or swing them outwards.
5. Place your feet on the ground.
6. Hold the wheelchair and, if necessary, also hold a fixed object in the vicinity.
7. Move slowly to chair.

6.5 Driving and steering the wheelchair

You drive and steer the wheelchair using the handrims.



CAUTION!

A heavy load hanging on the backrest can affect the wheelchair's centre of gravity.

- Change your driving style accordingly.

6.6 Negotiating steps and kerbs



WARNING!

Risk of overturning

When negotiating steps you could lose your balance and tip the wheelchair over.

- Always approach steps and kerbs slowly and carefully.
- Do not go up or down steps that are higher than 15 cm.



CAUTION!

An activated anti-tip device prevents the wheelchair from tipping backwards.

- Deactivate the anti-tip device before going up or down steps or kerbs.



WARNING!

Risk of injury to the assistant and damage to the wheelchair

Tilting the chair with a heavy user can hurt the assistant's back and damage the chair.

- Make sure to be able to safely control the wheelchair with a heavy user before performing a tilting maneuver.

6.6.1 Going down a step with an assistant



1. The assistant should then hold the wheelchair in this position, push it carefully down the step and then tilt it forwards until the front wheels are back on the ground.
2. The assistant should grasp both push handles, push downwards firmly and tilt the wheelchair backwards so that the front wheels lift off the ground.
3. Move the wheelchair right up to the kerb and hold the handrims.

6.6.2 Going up a step with an assistant



WARNING!

Risk of serious injuries

Going up steps and kerbs often than the normal use can cause a fatigue break of the wheelchair backrest and the user might fall out of the wheelchair.

- Make sure that the wheelchair can be controlled by the user or the assistant before performing a tilting maneuver.

1. Move the wheelchair backwards until the rear wheels touch the kerb.

- The assistant should grasp both push handles, push downwards firmly and tilt the wheelchair backwards so that the front wheels lift off the ground, then pull the rear wheels over the kerb until the front wheels can be placed back on the ground.

6.7 Going up and down stairs



WARNING

Risk of overturning

When negotiating stairs you could lose your balance and overturn your wheelchair.

- Always use two assistants when negotiating stairs with more than one step.



- You can go up and down stairs by taking them one step at a time, as described above. The first assistant should stand behind the wheelchair holding the push handles. The second assistant should hold a solid part of the front frame to steady the wheelchair from the front.

6.8 Negotiating ramps and slopes



WARNING!

Risk due to wheelchair being out of control

When negotiating slopes or gradients your wheelchair could tip backwards, forwards or sideways.

- Always have an assistant behind the wheelchair when approaching long slopes.
- Avoid lateral slopes.
- Avoid slopes of more than 7°.
- Avoid jerking when changing direction on a slope.



CAUTION!

Your wheelchair could run away even on slightly sloping ground if you do not control it using the handrims.

- Use the parking brakes if your wheelchair is stationary on sloping ground.

Going up slopes

To go up a slope, you must create some momentum, keep up the momentum and control the direction at the same time.



- Bend your upper body forwards and propel the wheelchair with quick, powerful strokes on both handrims.

Going down slopes

When going down slopes, it is important to control your direction and particularly your speed.

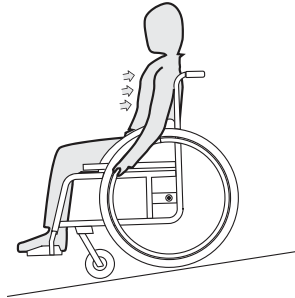

- Lean back and carefully allow the handrims to run through your hands. You should be able to stop the wheelchair at any time by gripping the handrims.



CAUTION!

Risk of burning your hands

If you brake for a long time, a lot of frictional heat is produced at the handrims (especially anti slip handrims).

- Wear suitable gloves.

6.9 Stability and balance when seated

Some everyday activities and actions require you to lean forwards, sideways or backwards out of the wheelchair. This has a major effect on the wheelchair's stability. To keep your balance at all times, proceed as follows:

6.9.1 Leaning forwards



WARNING!

Risk of falling

If you lean forwards out of the wheelchair you could fall out of it.

- Never bend too far forwards and do not shift forwards in your seat to reach an object.
- Do not bend forwards between your knees to pick up something off the floor.

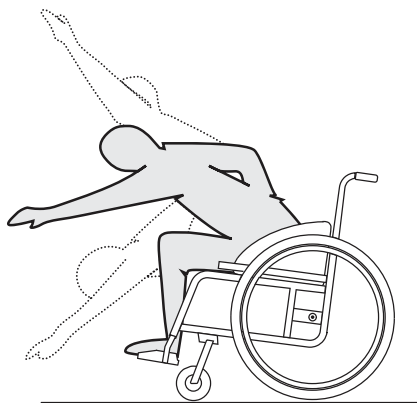

1. Point the front wheels forwards. (To do this, move your wheelchair forwards slightly then back again.)
2. Apply both parking brakes.
3. When leaning forwards your upper body must remain over the front wheels.

6.9.2 Reaching backwards



CAUTION!

Risk of falling

If you lean too far backwards you could tip your wheelchair over.

- Do not lean out over the backrest.
- Use an anti-tip device.

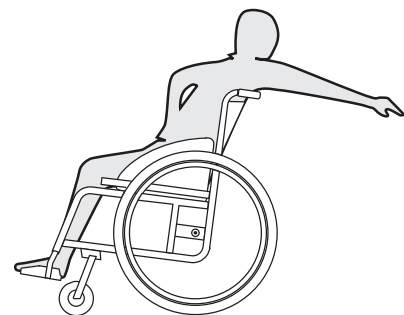

1. Point the front wheels forwards. (To do this, move your wheelchair forwards slightly then back again.)
2. Do not apply the parking brakes.
3. When reaching backwards do not reach so far that you have to change your sitting position.

7 Transport



WARNING!

Risk of injury if the wheelchair is not properly secured

In the event of an accident, braking manoeuvre, etc. you may suffer serious injuries from flying wheelchair parts.

- Firmly secure all wheelchair components in the means of transport to prevent them from coming loose during the journey.

7.1 Lifting the wheelchair

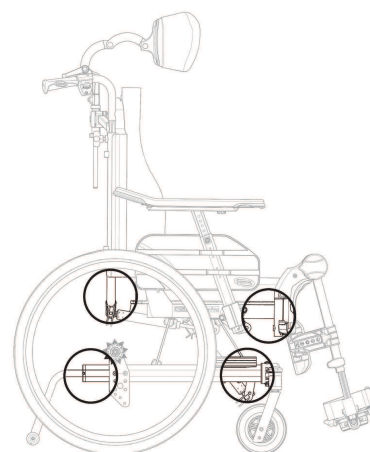

1. Always lift the wheelchair by grabbing the frame at the points shown in the picture.
2. Never lift the wheelchair by the removable armrests or the footrests.
3. Ensure that the backrest and push handles are securely in place.
4. See 2.1 *Safety Information*, page 5 **Safety instructions/Propelling techniques**.

7.2 Disassembly for transport

The wheelchair is easy to prepare for transport.

7.2.1 Folding the backrest

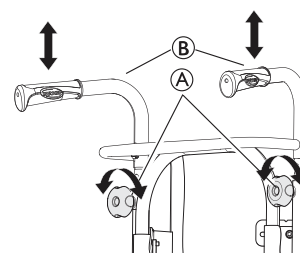

1. Remove the backrest cushion.
2. Loosen the handwheels (A) and lower the push handles/ push bar (B) to the lowest position.

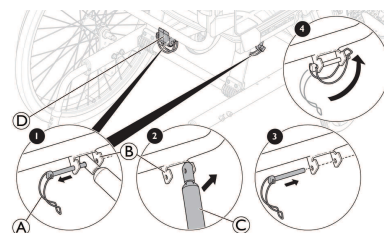

3. Carefully remove the safety shackle (A) from the attachment (B).
4. Gently press the backrest forwards.
5. Lift the piston (C) upwards.
6. Fold the backrest and let it rest on the seat.
7. Put the safety shackle (A) back into the attachment (B), the plastic guide-block (D) (gas-spring version only) and lock it in place for transport.



Ensure the cables are not pinched or damaged while folding the backrest.

7.2.2 Push handles/ push bar

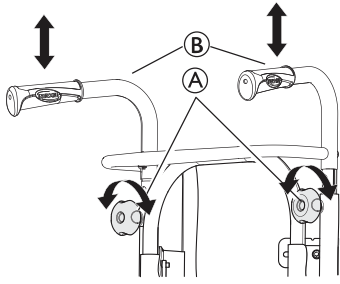

1. Loosen the two handwheels (A).
2. The height of the push handles (B) can be adjusted simply by pulling the handles upwards or pushing them downwards.

7.2.3 Angle adjustable leg rests

To install or remove the Swing away, Angle adjustable leg rest, see 3.9.2 *Swing away, angle adjustable leg rests, page 14.*

7.2.4 Fixed leg rests

To install or remove the Swing away, Fixed leg rest, see 3.9.1 *Swing away leg rests, page 14.*

7.2.5 Front castors

To verify front castors, see 8.3 *Maintenance schedule, page 33.*

7.2.6 Rear wheels

To install or remove the front castors, refer to 5.8 *Installing and removing rear wheels, page 24.*

7.2.7 Removing and installing the anti-tip device



WARNING! Risk of tipping

If the locking mechanism of the anti-tip device is not fully engaged, the anti-tip device can become loose during use. The wheelchair can tip backwards.

- Always ensure that the anti-tip devices are fully engaged whenever you install an anti-tip device.

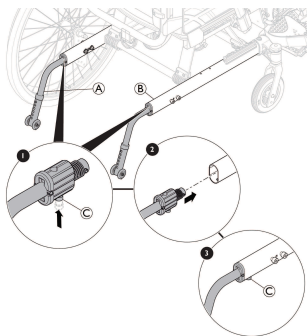

Removing the anti-tip devices

1. With one hand, hold the wheelchair upright.
2. With the other, using your thumb, press the locking mechanism (C) under the chassis frame (B).
3. Keep it pressed and pull the anti-tip device (A) out of the chassis frame (B).

Installing the anti-tip device

1. With one hand, hold the wheelchair upright.
2. With the other, using your thumb, press the locking mechanism (C) under the anti-tip device bracket (A).
3. Keep it pressed and push the anti-tip device (A) in the chassis frame (B).
4. Make sure there is an audible click and ensure that the anti-tip device (A) is secure.

7.3 Transporting the mobility device without occupant



WARNING!

Risk of injury if the wheelchair is not properly secured

In the event of an accident, braking manoeuvre, etc. you may suffer serious injuries from flying wheelchair parts.

- Firmly secure all wheelchair components in the means of transport to prevent them from coming loose during the journey.



You can remove the rear wheels when transporting the wheelchair.



NOTICE!

Excessive wear and abrasion could affect the strength of load-bearing parts.

- Do not pull your wheelchair across abrasive surfaces without the wheels fitted (e.g. pulling the frame over tarmac).



CAUTION!

Risk of injury

- If you are unable to fasten your mobility device securely in a transport vehicle, Invacare recommends that you do not transport it.

Your mobility device may be transported without restrictions, whether by road, rail or by air. Individual transport companies have, however, guidelines which can possibly restrict or forbid certain transport procedures. Please ask the transport company regarding each individual case.

- We strongly recommend securing the mobility device to the floor of the transporting vehicle.

7.4 Transporting the occupied wheelchair in a vehicle

Even when the wheelchair is properly secured and the following rules are met, injuries to passengers may occur in a collision or sudden stop. Therefore we strongly recommends transferring the wheelchair user to the vehicle seat. Do not make alterations or substitutions to points of the wheelchair (structure, frame or parts) without the written consent of Invacare GmbH. The wheelchair has been successfully tested according to the requirements of ISO 7176–19 (Frontal impact).



WARNING!

Risk of serious injury or death

- To use the wheelchair as a seat in a vehicle the backrest height must be at least 500 mm.

To transport the wheelchair with user in a vehicle, a restraint system must be installed in the vehicle. Wheelchair tie down (four point tie down) and occupant restraint systems must be approved according to ISO 10542-1. Contact your local Invacare authorised provider for more information on getting and installing an approved and compatible restraint system.

! NOTICE!

- Before your journey, contact the transporter and request information about the capability for the required equipment.



WARNING!

Risk of serious injury or death

If, for some reason, it is impossible to transfer the wheelchair user to a vehicle seat, the wheelchair can be used as a seat in a vehicle if the following procedures and regulations are followed.

- The configuration of the wheelchair is compatible with use as a seat in a motor vehicle (tie-down positions marked with labels).
- The wheelchair must be secured in the vehicle with a 4-point wheelchair restraint system.
- The user must wear a 3-point belt restraint secured to the vehicle.



NOTICE!

- Refer to the user manuals supplied with the restraint systems.
- The following illustrations may differ depending on the restraint system supplier.



WARNING!

Risk of serious injury or death

Wheelchairs have been crash tested according ISO7176-19, to simulate their behavior when used as forward-facing seats in motor vehicles by children and adults with a body mass equal to or greater than 22 kg.

- Do not use the wheelchair as a seat in a vehicle when the user weight is lower than 22 kg.

1. If the vehicle is equipped with a head restraint and the wheelchair with the head/neck support, then assess with a clinician which one should be used.



Our head and neck supports are not restraint devices. Nevertheless, they have been crash tested to verify their attachment points.

7.4.1 Securing the wheelchair and its occupant



The choice of wheelchair configuration (seat width and depth, wheelbase) influences maneuverability and access to motor vehicles.



WARNING!

Risk of serious injury or death

Injury or damage may occur from wheelchair components or options loosened during a collision or sudden stop.

- Ensure all removable or detachable components and options are removed from the wheelchair and securely stored in the vehicle.
- Disconnect the hand control (electrical version only) from its connection to the control box and securely stored in the vehicle.



NOTICE!

Injury or damage may occur to wheelchair during a collision or sudden stop.

- It is essential to have your wheelchair checked by a qualified technician after an accident or collision.

• Backrest and seat angles:



When transporting an occupied wheelchair in a vehicle, the recommended angles for backrest and seat are the following:

- 4° for the backrest and 4° for the seat.

• Ramps and slopes:



WARNING!

Risk of injury

Risk due to wheelchair being out of control.

- Never leave the user unattended when transporting the wheelchair up or down ramps or slopes.



Therefore we strongly recommend transferring the wheelchair user to the vehicle with the posture belt on.

• Adjusting the posture belt



WARNING!

Risk of serious injury or death

- The posture belt can be used in addition but never as a substitute for an approved passenger restraint system.

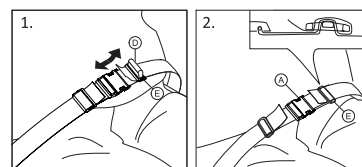

1. Adjust posture belt to fit the wheelchair occupant, see 4.8 Posture belt, page 21 .

7.4.2 Securing the wheelchair with a 4-point restraint system



WARNING!

Risk of serious injury or death

Make sure there is sufficient free space around the wheelchair and user to avoid the user making contact with other vehicle occupants, unpadding parts of the vehicle, wheelchair options or anchor points of the restraint system.

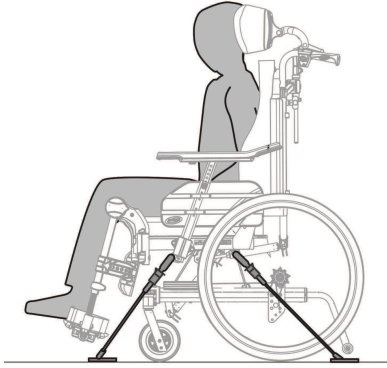

WARNING!

Risk of injury

- Place the wheelchair with the user forward-facing in direction of vehicle travel.
- Engage the wheelchair parking brakes.
- Activate the anti-tip device.

The wheelchair tie down points where the restraint system snaps are marked with snap hook symbols (see following figures and 2.3 Labels and symbols on the product, page 7).



Front side tie-down positions for snap hooks:

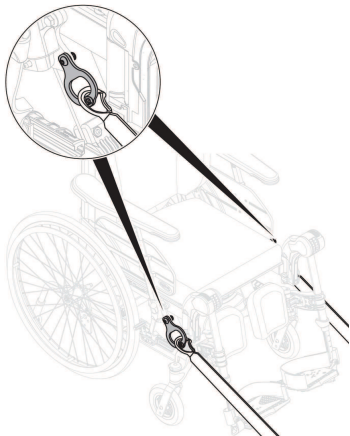

1. Attach the front straps above the castor supporters as shown in the figure above (see location of the snap hook symbol).
2. Attach front straps to the rail system referring to best practice recommended instructions from the 4-point wheelchair restraint system manufacturer.
3. Disengage parking brakes and apply tension front straps by

- pulling the wheelchair backwards from the rear.
4. Re-engage parking brakes.

Rear side tie-down positions for snap hooks:

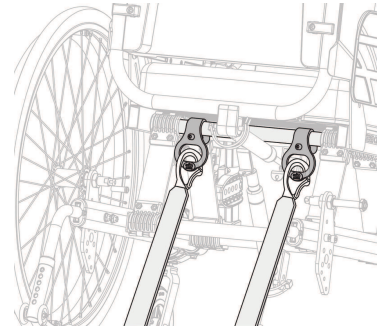

1. Attach the snap hooks of the rear straps to the vertical rear **B** on the rear wheel attachment area.
2. Attach rear straps to the rail system referring to best practice recommended instructions from the manufacturer.
3. Tighten the straps.



NOTICE!

Make sure that the snap hooks are covered with slip resistant material to avoid laterally slipping on the axle.

7.4.3 Fastening the 3-point belt restraint



WARNING!

Risk of injury

- Ensure that the 3-point belt restraint fits as tightly across the user's body as possible without discomfort and no belt webbing is twisted.
- Ensure the 3-point belt restraint is not held away from the user's body by parts of the wheelchair such as armrests or wheels etc.
- Ensure the 3-point belt restraint has a clear path from the user to the anchor point without interference by any part of the vehicle, wheelchair, seating or option.
- Ensure the pelvic-belt restraint fits snugly over the occupant's pelvis and is not allowed to ride up into the abdominal area.
- Ensure the user is able to reach the release mechanism unaided.

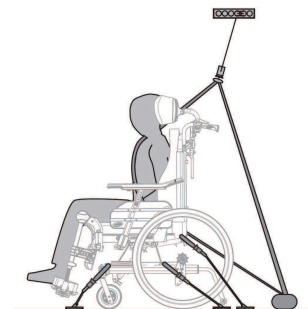

NOTICE!

The illustration above may differ depending on the restraint system supplier.

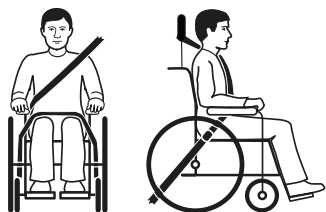

1. The 3-point belt restraint should fit as tightly across the user's body as possible without discomfort.

NOTICE!

- Ensure that the belt webbing is not twisted when in use.

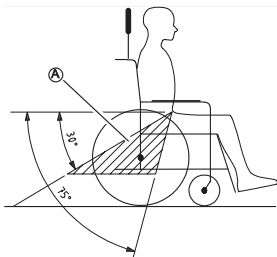

NOTICE!

- Apply the pelvic belt restraint of the 3-point-belt restraint low across the pelvis so that the angle of the pelvic belt is within the preferred zone **A** of 30° to 75° to the horizontal. A steeper angle is preferred, but never exceeding 75°.



i The image shows an incorrect placement of three-point belt restraint.

2. The belt restraint must not be held away from the user's body by parts of the wheelchair such as armrests or wheels etc.
3. If the vehicle is equipped with a head restraint and the wheelchair with the head/neck support, then assess with a clinician which one should be used.

i Our head and neck supports are not restraint devices. Nevertheless, they have been crash tested to verify their attachment point.

8 Maintenance

8.1 Safety information



WARNING!

Some materials deteriorate naturally over time. This could result in damage to wheelchair components.

- Your wheelchair should be checked by a qualified technician at least once a year or if it has not been used for a long period.



Packaging for return:

The wheelchair shall be sent to the authorized provider in an appropriate packaging to avoid damage during the shipment.

8.2 Daily performance check

Check that the following parts are correctly mounted on the wheelchair:

- Wheels
- Backrest
- Anti-tip device
- Push handles
- Footrests

8.3 Maintenance schedule

To ensure safe and reliable operation, carry out the following visual checks and maintenance regularly or have it carried out by another person.

	Weekly	Monthly	Annually
Check the tyre pressure	x		
Check that castors and/or rear wheels are seated correctly	x		
Check posture belt	x		
Check the reclining and tilting mechanisms		x	
Check the castors and its fixation		x	
Check bolts		x	
Check spokes		x	
Check parking brakes		x	
Check wheel-chair by a qualified technician			x

General visual check

1. Examine wheelchair for loose parts, cracks or other defects.
2. If you find anything, stop using your wheelchair immediately and contact an authorized provider.

Check the tyre pressure

1. Check the tyre pressure, see *11.3 Tyres, page 40*.
2. Inflate the tyres to the required pressure.
3. Check the tyre tread at the same time.
4. If necessary, change the tyres.

Check that castors and/or rear wheels are seated correctly

1. Pull on the castor and/or rear wheel to check that the removable axle is seated correctly. The castor or wheel should not come off.
2. If the castors and /or rear wheels are not engaged properly, remove any dirt or deposits. If problem persists, have the removable axles re-fitted by a qualified technician.

Check posture belt

1. Check that the posture belt is adjusted correctly.

! **NOTICE!**
Risk of sliding/ strangulation / falling

- Loose posture belts must be adjusted by a healthcare professional.
- Damaged posture belts must be replaced by a qualified technician.

Check the reclining and tilting mechanisms

1. Check that the reclining and tilting mechanisms are easy operating

Check the castors and its fixation

1. Check that the castors turn freely.
2. Push and pull in the 3 directions (front and rear; left and right; up and down) to observe that is no free play and movement, also check that there is no visual damage.

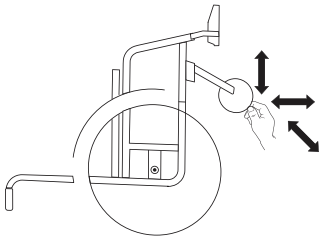

3. Remove any dirt or hair from the castor bearings.
4. Faulty or worn out castors fixation must be replaced by a qualified technician.

Check the bolts

Bolts can work loose through constant use.

1. Check that the bolts are tight (on the footrest, seat cover, sides, backrest, frame, seat module).
2. Tighten any loose bolts with the suitable torque.

! **NOTICE!**
 Self-locking screws/nuts or thread-locking adhesive are used for several connections. If these are loosened, they must be replaced by new self-locking screws/nuts or they must be secured using new thread-locking adhesive.

- Self-locking screws/nuts must be replaced by a qualified technician.

Check the spoke tension

The spokes should not be loose or distorted.

1. Loose spokes must be tightened by a qualified technician.
2. Broken spokes must be replaced by a qualified technician.

Check the parking brakes

1. Check that the parking brakes are positioned correctly. The brake is set correctly if the brake shoe depresses the tyre by a few millimeters when the brake is engaged.
2. If you find that the setting is not correct, have the brakes correctly adjusted by a qualified technician.

! **NOTICE!**
 — The parking brakes must be reset after replacing the rear wheels or changing their position.

Check after a heavy collision or blow

! **NOTICE!**
 The wheelchair can sustain visibly undetectable damage as a result of a heavy collision or hard blow.

- It is essential to have your wheelchair checked by a qualified technician after a heavy collision or hard blow.

Repairing or changing an inner tube

1. Remove the rear wheel and release any air from the inner tube.
2. Lift one tyre wall away from the rim using a bicycle tyre lever. Do not use sharp objects such as a screwdriver which could damage the inner tube.
3. Pull the inner tube out of the tyre.
4. Repair the inner tube using a bicycle repair kit or, if necessary, replace the tube.
5. Inflate the tube slightly until it becomes round.
6. Insert the valve into the valve hole on the rim and place the tube inside the tyre (the tube should lie right round the tyre with no creases).
7. Lift the tyre wall over the edge of the rim. Start close to the valve and use a bicycle tyre lever. When doing this, check all the way round to ensure that the inner tube is not trapped between the tyre and the rim.
8. Inflate the tyre to the maximum operating pressure. Check that no air is escaping from the tyre.

Spare parts

 All spare parts may be obtained from an Invacare authorized provider.

8.4 Maintenance electrical version

! **CAUTION!**
Risk of damage to the product

- Do not use chemicals.
- Handle batteries carefully.
- Do not use strong solvents, basic or alkaline liquids.
- Check that the actuators and system function properly.
- For an optimum lifetime, the product must be connected to the mains voltage as often as possible. It is recommended to load the battery at least every 3rd month.
- Test the battery function at least once a year.

8.5 Cleaning and disinfection

8.5.1 General safety information



CAUTION

Risk of contamination

- Take precautions for yourself and use appropriate protective equipment.



NOTICE!

Wrong fluids or methods can harm or damage the product.

- All cleaning agents and disinfectants used must be effective, compatible with one another and must protect the materials they are used to clean.
- Never use corrosive fluids (alkalines, acid etc.) or abrasive cleaning agents. We recommend an ordinary household cleaning agent such as dishwashing liquid, if not specified otherwise in the cleaning instructions.
- Never use a solvent (cellulose thinner, acetone etc.) that changes the structure of the plastic or dissolves the attached labels.
- Always make sure that the product is completely dried before taking it into use again.



For cleaning and disinfection in clinical or long-term care environments, follow your in-house procedures.

8.5.2 Cleaning intervals



NOTICE!

Regular cleaning and disinfection enhance smooth operation, increases the service life and prevents contamination.

Clean and disinfect the product:

- regularly while in use,
- before and after any service procedure,
- when it has been in contact with any body fluids,
- before using it for a new user.

8.5.3 Cleaning



NOTICE!

Dirt, sand and seawater can damage the bearings and steel parts can rust if the surface is damaged.

- Only expose the wheelchair to sand and seawater for short periods and clean it after every trip to the beach.
- If the wheelchair is dirty, wipe off the dirt as soon as possible with a damp cloth and dry it carefully.

- Remove any options fitted (only options which do not require tools).
- Wipe down the individual parts using a cloth or soft brush, ordinary household cleaning agents (pH = 6 - 8) and warm water.
- Rinse the parts with warm water
- Thoroughly dry the parts with a dry cloth.



Car polish and soft wax can be used on painted metal surfaces to remove abrasions and restore gloss.

Cleaning upholstery

For cleaning upholstery refer to the instructions on the labels of the seat, cushion and backrest cover.



If possible, always overlap hook and loop strips (the self-gripping parts) when washing, to minimize lint and thread build-up on hook strips and prevent damage to upholstery fabric by these.

8.5.4 Washing

- Remove all loose and removable covers and wash them in a washing machine according to the washing instructions for each cover.
- Remove all padded parts such as seat cushions, armrests, headrest or neckrest with fixed padded parts, calf pads and so on and clean them separately.



The padded parts can not be cleaned with a high-pressure cleaner or water jet.

- Spray the wheelchair chassis with detergent, for example a car-cleaning agent with wax, and leave on to work.
- Rinse the wheelchair chassis with a high-pressure cleaning or ordinary jet of water depending on how dirty the wheelchair is. Do not aim the jet towards bearings and draining holes. If the wheelchair chassis is washed in a machine the water must not be hotter than 60°C.



Only use water and soft soap to clean the table.

- Leave the wheelchair to dry in a drying cabinet. Remove parts where water has collected for example in end tubes, ferrules etc. If the wheelchair has been washed in a machine, blow-drying with compressed air is recommended.

8.5.5 Multi-stretch polyurethane (PU) coated fabric

Lighter stains on the fabric may be neutralized with a soft damp cloth and some neutral detergent. To neutralize larger, more persistent stains, wipe the fabric with alcohol or turpentine substitutes, and wash with hot water and a neutral detergent.

The fabric can be washed at temperatures up to 60°C. Normal detergents can be used.



All parts of the wheelchair with multi-stretch polyurethane (PU) coated fabric upholstery, such as armrest pads, calf pads, headrest or neckrest, should be cleaned according to the instruction above.

Electrical version

! NOTICE!

- The wheelchair with electrical backrest or tilt is protected according to IPX4. This means the product can be washed with a brush and water. The water can be under pressure (eg garden hose), but high pressure water must not be sprayed directly towards the electrical system.
- Max washing temperature 20°C.
- Do not use a steam cleaner.
- Before cleaning, make sure that the power plug is not connected.
- Interconnected cables must remain plugged in when cleaning the product.
- Retract the actuator to the innermost position when cleaning to avoid degreasing piston rod.

8.5.6 Disinfection

The wheelchair may be disinfected by spraying or wiping with tested, approved disinfectants.

 Spray a soft cleaning and disinfecting product (bactericidal and fungicide meeting the EN1040 / EN1276 / EN1650 standards) and follow the instructions given by the manufacturer.

1. Wipe down all generally accessible surfaces with a soft cloth and ordinary household disinfectant.
2. Allow the product to air-dry.

9 After use

9.1 Storage

! NOTICE!

Risk of damage to the product

- Do not store the product near heat sources.
- Never store other items on top of the wheelchair.
- Store wheelchair indoors in a dry environment.
- Refer to temperature limitation in *11.5 Environmental conditions, page 40.*

After long-term storage (more than four months) the wheelchair must be inspected in accordance with the *8.3 Maintenance schedule, page 33.*

9.1.1 Storage electrical version

Short-term storage

Do not remove the battery pack **A** located under the seat plate, disconnect the cable from the battery **A** or from the control box **B**.

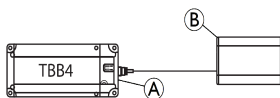

Long-term storage

Storing Mobility Device and Battery

- Even not being use, batteries discharge themselves. The best practice is to disconnect the battery supply from the control box if storing the mobility device longer than two weeks. Disconnect the battery pack from the control box or battery, see Short-term Storage above. In case of doubt of which cable should be disconnected, contact your authorized provider.
- Battery should always be fully charged before storing.
- When you store the mobility device more than four weeks, check the battery every six months and recharge as needed (before gauge reads half full) to avoid damage

Preparing mobility device for use

- The battery pack must be charged before use.
- Re-connect the battery supply to the control box.
- Alternatively, press (above one second) on the **ON** button **C** located on the front right side of the battery box **A**.

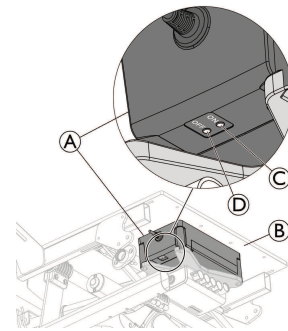

In some case, after recharging the battery at a very low level or disconnect / reconnect the battery supply, you may need to press (more than one second) on the "ON" **C** located on the front right side of the battery box **A**, fixed under the seat plate **B**.

9.2 Disposal

Be environmentally responsible and recycle this product through your recycling facility at its end of life.

Disassemble the product and its components, so the different materials can be separated and recycled individually.

The disposal and recycling of used products and packaging must comply with the laws and regulations for waste handling in each country. Contact your local waste management company for information.

9.2.1 Disposal electrical version



WARNING!

Environmental Hazard

Device contains batteries. This product may contain substances that could be harmful to the environment if disposed of in places (landfills) that are not appropriate according to legislation.

- DO NOT dispose of batteries in normal household waste.
- Batteries MUST be taken to a proper disposal site. The return is required by law and free of charge.
- Do only dispose discharged batteries.
- Cover terminals of lithium batteries prior to disposal.

9.3 Reconditioning

This product is suitable for reuse. To recondition the product for a new user, carry out the following actions:

- Inspection
- Cleaning and disinfection
- Adaptation to the new user

For detailed information, see *8.3 Maintenance schedule, page 33* and the service manual for this product.

Make sure that the user manual is handed over with the product.

If any damage or malfunction is detected, do not reuse the product.

10 Troubleshooting

10.1 Safety information

Faults may arise as a result of daily use, adjustments or changing demands on the wheelchair. The tables *10.2 Identifying and repairing faults, page 38* and *10.3 Identifying and repairing faults, electrical version, page 38* shows how to identify and repair faults.



CAUTION!

- Contact your specialist dealer immediately if you notice a fault with your wheelchair, e.g. a significant change in handling.



CAUTION!

- Some of the actions listed must be carried out by an authorised specialist dealer. These are indicated. We recommend that all adjustments are carried out by a specialist dealer.

10.2 Identifying and repairing faults

Fault	Possible cause	Action
The wheelchair does not travel in a straight line	Incorrect tyre pressure on one rear wheel	Correct tyre pressure.
	One or more spokes broken	Replace faulty spoke(s), → authorised dealer
	Spokes tightened unevenly	Tighten loose spokes, → authorised dealer
	Front wheel bearings are dirty or damaged	Clean or replace the bearings, → authorised dealer
The wheelchair tips backwards too easily	Rear wheels are mounted too far forwards	Mount the rear wheels further back, → authorised dealer
	Back angle too large	Reduce the backrest angle, → authorised dealer
	Seat angle too large	Mount the front wheel upper on the front fork, → authorised dealer
The brakes are gripping poorly or asymmetrically	Incorrect tyre pressure in one or both rear tyres	Correct tyre pressure
	Brake setting incorrect	Correct the brake setting, → authorised dealer
Rolling resistance is very high	Tyre pressure in rear tyres is too low	Correct tyre pressure
	Rear wheels not parallel	Ensure the rear wheels are parallel, → authorised dealer
The front wheels wobble when moving fast	Too little tension in front wheel bearing block	Tighten the nut on the bearing block axle slightly → authorised dealer
	Front wheel has worn smooth	Change front wheel → authorised dealer
The front wheel is stiff or stuck	Bearings are dirty or faulty	Clean or replace the bearings → authorised dealer
The wheelchair is very difficult to unfold	Backrest cover is too tight	Loosen the Velcro bands of the backrest cover a little

10.3 Identifying and repairing faults, electrical version

Fault	Possible cause	Action
Tilt or recline does not move	End of stroke reached	Operate opposite button
	Battery is not charged	Charge the battery
	Hand control not connected	Ensure hand control correctly connected to control unit.
	Hand control defective	Call qualified technician to replace hand control
	Control unit defective	Call qualified technician to replace control unit
	Cables entangled or pinched	Call qualified technician to replace cables
	Hand control function is locked	Call qualified technician to unlock the hand control function
The hand control beeps when it is used.	Battery level is low	Charge the battery
	The wheelchair has been used outdoors in cold temperatures (below -10°C)	Let the wheelchair get warmer. Restart the control box, see <i>Charging the battery, page 11</i> for more instructions.



In some case, after recharging the battery at a very low level, you may need to press (more than one second) on the **ON** button located on right side of the battery box, fixed under the seat plate, *9.1.1 Storage electrical version, page 36*.

11 Technical data

11.1 Dimensions and weights

All dimension and weight specifications refer to a wide range of the wheelchair in a standard configuration. Dimension and weight (based on ISO 7176-1/5/7) may alter according to different configurations.

- ! NOTICE!**
- In some configurations, the overall dimensions of the wheelchair when it is ready for use exceeds the authorised limits and the access to emergency escape routes is not possible.
 - In some configurations, the wheelchair exceeds the size recommended for travelling by train in the EU.

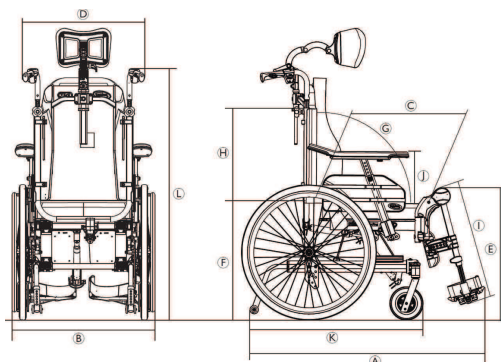

		Rea Clematis Pro
	Maximum load of the wheelchair*	135 kg
Ⓐ	Overall length with leg rests	995–1470 mm
Ⓑ	Overall width	605-770 mm
	Stowage width	535 – 760 mm
	Stowage height	515 – 590 mm
	Stowage length	from 705 – 840 mm
	Total mass**	from 37.5 – 41.4 kg
	Mass of the heaviest part**	20 – 24.9 kg
	Static stability downhill	11°– 27°
	Static stability uphill	11° – 31°
	Static stability sideways	12° – 22°
	Seat plane angle	-3° – +22° ***/ 0° – +25° ***
Ⓒ	Effective seat depth	Fixed: 420 – 480 mm Adjustable: 430 – 500 mm

		Rea Clematis Pro
Ⓓ	Effective seat width	Fixed: 390 – 490 mm, in increments of 50 mm Adjustable: 390 – 590 mm, in increments of 25 mm
Ⓔ	Seat surface height at front edge	400 – 450 mm, in increments of 25 mm
Ⓕ	Seat surface height at rear edge	400 – 450 mm, in increments of 25 mm
Ⓖ	Backrest angle	Gas-spring recliner: 0°/+30°, stepless Electrical recliner: 0°/+30°, stepless
Ⓗ	Backrest height	570 – 710 mm
Ⓘ	Footrest-to-seat distance	355 – 465 mm, in increments of 10 mm
	Leg-to-seat-surface angle	90° – 180°
Ⓢ	Armrest-to-seat height	Range: 230 – 350 mm Standard: 230 – 340 mm Comfort: 240 – 350 mm
	Front location of armrest structure	360 – 440mm
	Hand rim diameter	490 – 530 mm
	Horizontal location of axle	36 – 66 mm
	Minimum turning radius	800 – 880 mm
Ⓚ	Overall length without leg rests	780 – 1100 mm
Ⓛ	Overall height	1200–1550mm
	Pivot width	1450 mm
	Maximum slope angle brake	7°

* The maximum load of the wheelchair is the total of the maximum occupant mass and the maximum mass of any other items intended to be carried by the wheelchair. The maximum occupant mass is the maximum load of the wheelchair without additional load.

Example: for a wheelchair with a back pack of 10kg:
Maximum Occupant Mass = Maximum Load of the wheelchair = 10kg.

** Total mass in seat width 390 mm and with lightest configuration. If equipped with Electrical System, the mass increase is 5.5 kg.

*** If equipped with Electrical System, the total seat plane angle is increased by 5°.

11.2 Maximum weight of removable parts

Maximum weight of removable parts	
Part:	Maximum weight:
Legrest angle adjustable with calf pad and footrest	3.2kg
Armrest	2.0 kg
Rear wheel 600 mm (24") solid with handrim and spoke guard	2.5 kg
Headrest / Neckrest / Cheek support	1.4 kg
Trunk support	0.8 kg
Backrest cushion	2.0 kg
Seat cushion	1.9 kg
Table tray	3.9 kg

11.3 Tyres

The ideal pressure depends on the tyre type.

 Check on the side of the tyre, the maximum pressure is listed there.

Tyre	Max. pressure		
Pneumatic profiled tyre	4.5 bar	450 kPa	65 psi

 The size of the tyre is mentioned on the sidewall of the tyre. The change of appropriate tyres must be carried out by a qualified technician.

 In case of a tyre puncture consult a suitable workshop (e.g. bike repair shop, bicycle dealer ...) to have the tube replaced by a skilled person.





CAUTION!

— Tyre pressures must be equal in both wheels to avoid reduced ride comfort, to maintain brake efficiency and smooth wheelchair propelling.

11.4 Materials

Component	Material
Chassis, backrest tubes	Steel, powder coated
Plastic parts like push handles, brake handles, foot plates and parts of most options	Thermoplastic (e.g. PA, PE, PP, ABS and TPE) according to marking on the parts
Upholstery (seat and backrest)	Foam PUR and polyether, polyurethane-coated fabric and plush
Table	ABS
Seat plate	Coated Birch plywood
Other metal parts	Zinc alloys, aluminum alloys and steel
Screws, washers and nuts	Steel, corrosion free

 All materials used are protected against corrosion. We use only REACH compliant materials and components.

 Theft and metal detection systems: in rare cases the materials used in the wheelchair may activate theft and metal detection systems.

11.5 Environmental conditions

	Storage and transportation	Operation
Temperature	-20°C to 40°C	-5°C to 40°C
Relative humidity	20% to 90% at 30°C, not condensing	
Atmospheric pressure	800 hPa to 1060hPa	



Be aware that when a wheelchair has been stored under low temperatures, it must be adjusted to operating conditions before use.

11.6 Environmental conditions electrical version

	Storage and transportation	Operation
Temperature	-10°C to 50°C	-5°C to 40°C
Relative humidity	20 % to 80 %, not condensing	
Atmospheric pressure	700 hPa to 1060 hPa	



Be aware that when a wheelchair has been stored under low temperatures, it must be adjusted to operating conditions before use.

11.7 Electrical system — models equipped with electric tilt and backrest

Electrical System

Battery	24 V DC (DC = Direct current), 2 Ah / 2.2 Ah / Lead acid
Duty cycle	10 % (max 2 min. ON / 18 min. OFF)
	Applied Part complying with the specified requirements for protection against electrical shock according to IEC60601-1.
Degree of protection	IPx4 See label and label on each electric device for correct IP class. The lowest IP-classification decides the overall classification of the system. IPx4 The system is protected against water projected from any direction (not high pressure).

Charger

Input voltage	100 – 240 V AC (AC = Alternating current), 50 / 60 Hz, 1 A
Maximum output	29 V DC, 1.5 A
Protection class	 CLASS II equipment



For full details contact your Invacare authorized provider.

11.8 Electromagnetic compliance (EMC)

Products with electronic equipment needs to be installed and used according to the EMC information in this user manual.



WARNING!

Portable and mobile communications equipment can affect the operation of this product.

- In the case of the product moves itself unintentionally while being submitted to Electromagnetic interference, then stop immediately using the product and send it to check by a qualified technician.

This product has been tested and complies with the EMC limits specified by IEC 60601-1-2 for Class B equipment.



This product has a very low emissions and should not interfere with other equipment.



However, if other devices nearby should react inexplicably, run and stop this product and observe the devices.

- If nothing happens with the other devices, then this product is not causing the error.
- If other devices are behaving in an inexplicable manner, then this product is causing the error. Solve the problem by moving or increasing the distance between them.



United Kingdom & Ireland:

Invacare Ltd.
Pencoed Technology Park, Pencoed
Bridgend CF35 5AQ
Tel: (44) (0) 1656 776 200
uk@invacare.com
www.invacare.co.uk



UKRP Invacare UK Operations Limited
Unit 4, Pencoed Technology Park,
Pencoed
Bridgend CF35 5AQ
United Kingdom

 Invacare France Operations SAS
Route de St Roch
F-37230 Fondettes
France

1653395-G 2026-04-15

