



Küschall® K-Series

en **Manual Wheelchair
User Manual**

This manual **MUST** be given to the user of the product.

BEFORE using this product, this manual **MUST** be read and saved for future reference.



Contents

1 General	3
1.1 Introduction	3
1.2 Delivery Check	3
1.3 Symbols in this Document	3
1.3.1 Other Symbols	3
1.4 Warranty Information	3
1.5 Compliance	3
1.5.1 Product-specific standards	3
1.6 Service Life	3
1.7 Limitation of Liability	3
2 Safety	4
2.1 Safety Information	4
2.1.1 Specific Safety Requirements for Carbon Line Models	5
2.2 Safety Devices	6
2.3 Labels and symbols on the product	6
3 Product Overview	6
3.1 Product description	6
3.2 Intended use	7
3.3 Main parts of the wheelchair	7
3.4 Parking brakes	7
3.5 Backrest	8
3.5.1 Standard backrest cover	8
3.5.2 Adjusting the tension of the backrest cover	8
3.5.3 Backrest height / backrest angle	8
3.5.4 Push handles	9
3.5.5 Foldable push handles	9
3.5.6 Height-adjustable push handles	9
3.6 Armrests and side parts	9
3.6.1 Tubular armrest, non-locking, height-adjustable, removable, swivelling	9
3.6.2 Side Rest, stepless height-adjustable, non-locking	9
3.6.3 Mudguard	10
3.6.4 Clothes-guard	10
3.7 Calf strap	10
3.8 Rear wheel extension	11
3.9 Vario-Ax	11
3.10 Seat cushion	11
4 Options	11
4.1 Anti-tip device	11
4.2 Posture belt	12
4.3 Attachment when using positioning belt	12
4.4 Transit wheels	13
4.5 Cane holder	13
4.6 Tipper aid	13
4.7 Suspension	13
4.8 Passive Illumination	13
5 Setup	13
5.1 Safety Information	13
6 Using the wheelchair	14
6.1 Safety Information	14
6.2 Braking during use	14
6.3 Getting in and out of the wheelchair	14
6.4 Driving and steering the wheelchair	15
6.5 Negotiating steps and kerbs	15
6.6 Going up and down stairs	16
6.7 Negotiating ramps and slopes	16
6.8 Stability and balance when seated	16
6.9 Transporting the manual wheelchair without occupant	17
6.10 Transporting the occupied wheelchair in a vehicle	17
7 Transport	19
7.1 Safety information	19
7.2 Folding and unfolding the backrest	20
7.3 Removing and fitting the rear wheels	20
8 Maintenance	20
8.1 Safety Information	20
8.2 Maintenance schedule	20
8.3 Cleaning and disinfection	22
8.3.1 General safety information	22
8.3.2 Cleaning intervals	22
8.3.3 Cleaning	22
8.3.4 Disinfection	22
9 Troubleshooting	23
9.1 Safety information	23
9.2 Identifying and repairing faults	23
10 After use	24
10.1 Storage	24
10.2 Reconditioning	24
10.3 Disposal	24
11 Technical data	24
11.1 Dimensions and weights	24
11.2 Tyres	25
11.3 Materials	26
11.4 Environmental conditions	26

1 General

1.1 Introduction

This user manual contains important information about product handling. To ensure safety when using the product, read the user manual carefully and follow safety instructions.

Only use this product if you have read and understood this manual. Seek additional advice from a healthcare professional who is familiar with your medical condition and clarify any questions regarding the correct use and necessary adjustment with the healthcare professional.

There may be sections in this document, which are not relevant to your product. This document applies to all available models (on the date of printing). If not otherwise stated, each section in this document refers to all product models.

The models and configurations available in your country can be found in the country-specific sales documents. We reserve the right to alter product specifications without further notice.

Before reading this document, make sure you have the latest version. You find the latest version as a PDF on the Invacare website.

If you find that the font size in the printed document is difficult to read, you can download the PDF version from the website. The PDF can then be scaled on screen to a font size that is more comfortable for you.

Previous product versions may not be described in this manual's current revision. If you require assistance, please contact Invacare.

For more information about the product, for example product safety notices and product recalls, contact your Invacare distributor. See addresses at the end of this document.

In case of a serious incident with the product, you must inform the manufacturer and competent authority in your country.

1.2 Delivery Check

Any transport damage must be reported immediately to the transport company. Remember to keep the packaging until the transport company has checked the goods and a settlement has been reached.

1.3 Symbols in this Document

Symbols and signal words are used in this document and apply to hazards or unsafe practices which could result in personal injury or property damage. This document is printed in greyscale.

For your information, the safety messages have the following colour coding according to ANSI Z535.6: Danger (Red), Warning (Orange), Caution (Yellow) and Notice (Blue). See the information below for definitions of the signal words.



WARNING!

Indicates a hazardous situation that could result in serious injury or death if it is not avoided.



CAUTION!

Indicates a hazardous situation that could result in minor or slight injury if it is not avoided.



NOTICE!

Indicates a hazardous situation that could result in damage to property if it is not avoided.



Tips and Recommendations

Gives useful tips, recommendations, and information for efficient, trouble-free use.

1.3.1 Other Symbols

(Not applicable for all manuals)



UK Responsible Person

Indicates if a product is not manufactured in the UK.



Triman

Indicates recycling and sorting rules (only relevant for France).

1.4 Warranty Information

We provide a manufacturer's warranty for the product in accordance with our General Terms and Condition of Business in the respective countries.

Warranty claims can only be made through the provider from whom the product was obtained.

1.5 Compliance

Quality is fundamental to the company's operation, working within the disciplines of ISO 13485.

This product features the CE mark, in compliance with the Medical Device Regulation 2017/745 Class I.

This product features the UKCA mark, in compliance with Part II UK MDR 2002 (as amended) Class I.

We are continuously working towards ensuring that the company's impact on the environment, locally and globally, is reduced to a minimum.

We only use REACH compliant materials and components.

We comply with the current environmental legislations WEEE and RoHS.

1.5.1 Product-specific standards

The wheelchair has been tested in accordance with EN 12183. It includes testing for flammability.

For further information about local standards and regulations, contact your local Invacare representative. See addresses at the end of this document.

1.6 Service Life

The expected service life of this product is five years when used daily and in accordance with the safety instructions, maintenance intervals and correct use, stated in this manual. The effective service life can vary according to frequency and intensity of use.

1.7 Limitation of Liability

Invacare accepts no liability for damage arising from:

- Non-compliance with the user manual.
- Incorrect use.
- Natural wear and tear.

- Incorrect assembly or set-up by the purchaser or a third party.
- Unauthorised modifications, combinations and/or use of unsuitable spare parts.

2 Safety

2.1 Safety Information

This section contains important safety information for the protection of the wheelchair user and assistant and for safe, trouble-free use of the wheelchair.



WARNING!

Risk of serious injury or damage

Improper use of this product may cause injury or damage.

- If you are unable to understand the warnings, cautions or instructions, contact a health care professional or provider before attempting to use this equipment.
- Do not use this product or any available optional equipment without first completely reading and understanding these instructions and any additional instructional material such as user manual, service manual or instruction sheet supplied with this product or optional equipment.



WARNING!

Risk of death or serious injury

In case of fire or smoke, wheelchair occupants are at particular risk of death or serious injury, when they are not able to move away from the source of fire or smoke. Lighted matches, lighter and cigarettes can cause an open flame in the wheelchair surroundings or on clothes.

- Avoid using or storing the wheelchair near open flames or combustible products.
- Do not smoke while using the wheelchair.



WARNING!

Risk of accidents and serious injury

Accidents with resulting serious injury can occur if the wheelchair is improperly adjusted

- Contact your wheelchair provider in order to a qualified technician does the adjustments needed.



Invacare expects that the qualified technician is familiar with the product, with good technical knowledge to understand and follow the steps of the described instructions in this manual and equipped with proper tools.



WARNING!

Risk of overturning

The longitudinal position of the rear wheels axis of the wheelchair compared to the backrest position can affect its stability.

- Moving the rear wheels axis frontwards makes the wheelchair less stable, increasing the risk of tipping backwards. But it improves the manoeuvrability with a better grip position of the handrim and a short turning radius.
- Conversely, by moving the rear wheels axis backwards, the wheelchair is more stable and tilts less easily, but its maneuverability is reduced.
- Depending on the user's abilities and its particular safety limits, the decrease in stability can be compensated for by installing an anti-tip device.



WARNING!

Risk of tilting

The rear wheel axle position and the angle of your wheelchair's backrest are two of the key adjustments that can affect your stability.

- The changes of rear/front wheels position and/or angle fork adjustments must only be performed by a qualified technician after the assessment of your healthcare professional.



WARNING!

Risk due to driving style being unsuitable for environmental the conditions

There is a risk of skidding on wet ground, gravel or uneven terrain.

- Always adjust your speed and driving style to the conditions (weather, surface, individual ability, etc.).



WARNING!

Risk of injury

In a collision you could sustain injury to parts of your body that extend beyond the wheelchair (e.g. feet or hands).

- Avoid an unbraked collision.
- Never drive into an object head-on.
- Drive carefully through narrow passages.



WARNING!

Risk due to wheelchair being out of control

At high speed you could lose control of your wheelchair and overturn.

- Always adjust your driving speed to the given conditions.
- Avoid collisions in general.

**WARNING!****Risk of accidents**

Safety devices that are incorrectly set or no longer working (brakes, anti tip devices) can cause accidents.

- Always check that the safety devices are working before you use the wheelchair and have them regularly checked by a qualified technician or your provider.

**CAUTION!****Risk of injury**

Non-original or wrong parts may affect the function and safety of the product.

- Only use original parts for the product in use.
- Due to regional differences, refer to your local Invacare catalogue or website for available options or contact your Invacare distributor. See addresses at the end of this document.

**CAUTION!****Risk of injuries**

- In case of pressure sore or injured skin, protect your injure to avoid a direct contact with the fabrics of the device. Refer to a healthcare professional for medical advice.

**CAUTION!****Risk of injuries**

The use of a manual wheelchair can lead to shoulder pain. The following recommendations reduce this effect:

- Move the rear wheels further forwards so that the arms can move within the anatomical range.
- Make sure that the sits in an ergonomically seat position as the disability allows.

**CAUTION!****Risk of burning**

The wheelchair components can heat up when exposed to external sources of heat:

- Do not expose the wheelchair to strong sunlight before use.
- Before usage, check all components that come into contact with your skin for their temperature.

**CAUTION!****Risk of getting fingers caught**

There is always a risk of getting parts of the body e.g. fingers or arms, caught in the moving parts of the wheelchair.

- Take attention while activating and deactivating the mechanisms of moving parts, such as the removable axle of the rear wheel, folding backrest or anti-tip device.

**CAUTION!****Risk of tipping**

The hanging of additional load (back pack or similar items) onto your chair backposts can affect the rearward stability of your wheelchair.

- Invacare strongly recommend the use of anti-tipdevice (available as an option) when using your backposts with additional loa.

**NOTICE!**

When combining this product with another product, the restrictions of both products apply for the combination. E.g. the maximum user weight of one product in the combination may be lower.

- Only use combinations allowed by Invacare. Contact your Invacare distributor for information.
- Before use, read the user manual of each product and check the restrictions. The full compliance with the information, instructions and recommendations contained in both user manuals is necessary for a safe use.

**NOTICE!****Risk when using an add-on to support or substitute propelling the wheelchair**

For safety reasons, it must only be operated by persons who have the physical and mental ability to safely operate the wheelchair with the add-on attached to it in all possible situations (e.g. road traffic) and, in the event of the add-on failing to work or shutting down, are able to brake the wheelchair and stop safely. Any use contrary to the intended use involves a risk of injury.

At high speed you could lose control of your wheelchair and overturn.

- Drive carefully.
- Always adapt your speed and your driving style to the conditions (weather, surface, individual ability, etc.).
- Avoid collision.

An add-on to support or to substitute propelling the wheelchair increases the strain on the wheelchair structure.

- After each use of an add-on, check the wheelchair for frame cracks or loose screwing.
- If any sign of fatigue on the wheelchair structure, stop using the wheelchair immediately and contact a qualified technician.

2.1.1 Specific Safety Requirements for Carbon Line Models

**WARNING!****Risk of breakage****Risk of injury**

- You must not attach any add-on propulsion system to the carbon tubes comprising the wheelchair frame.
- Never drill holes in any of the carbon tubes.



CAUTION!

Risk of damage

There is a risk of deteriorating or damaging the carbon tubes of the wheelchair. We strongly recommend the following:

- Do not over tighten any attached objects (water bottle holder, telephone holder etc.) on a carbon tube.
- Avoid contact between the carbon and metallic parts. Consider using a soft material (rubber or silicone, for example) between these 2 materials.

2.2 Safety Devices



WARNING!

Risk of accidents

Safety devices that are incorrectly set or no longer working (brakes, anti-tip device) can cause accidents.

- Always check that the safety devices are working before you use the wheelchair and have them checked regularly by a qualified technician.

The functions of the safety devices are described in *3.1 Product description, page 6*

2.3 Labels and symbols on the product

Identification label

The identification label is attached to the frame of your wheelchair and gives the following information:

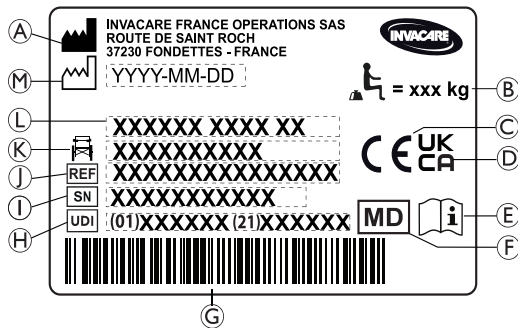

- Ⓐ Manufacturer's name and address
- Ⓑ Maximum load of the wheelchair
- Ⓒ European conformity mark
- Ⓓ United Kingdom conformity mark
- Ⓔ Consult user manual
- Ⓕ Medical device
- Ⓖ UDI barcode
- Ⓗ Unique Device Identifier, with bar code
- Ⓘ Serial Number
- Ⓝ Reference number
- Ⓚ Seat width
- Ⓛ Product name
- Ⓜ Date of manufacture

	Maximum load of the wheelchair or Maximum occupant mass without any additional load.
	Consult user manual.
	Indicates a hazardous situation that could result in serious injury or death if it is not avoided.

Non-locking side parts warning label

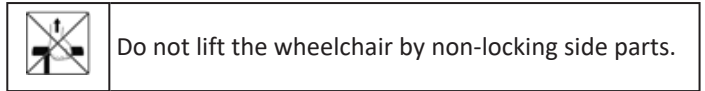

Posture belt information label



Reclining mechanical backrest information label

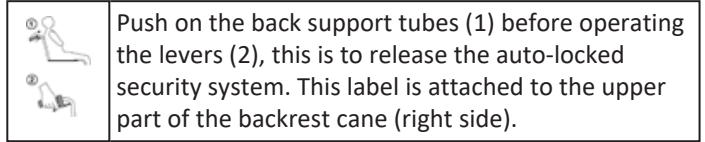

Snap hook symbols

Depending on the configuration, some wheelchairs may be used as a seat in a motor vehicle, some may not.

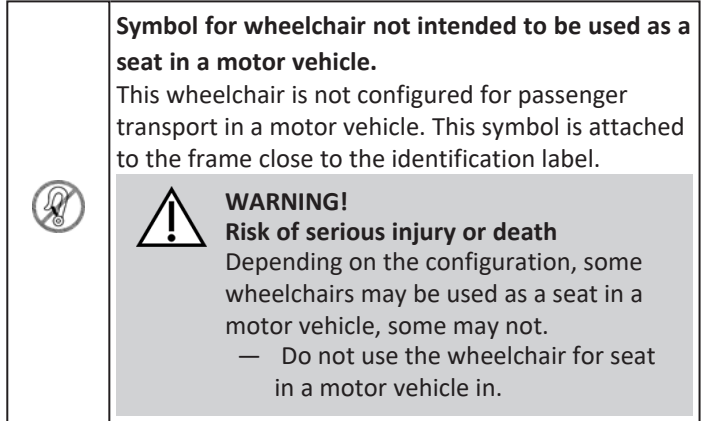
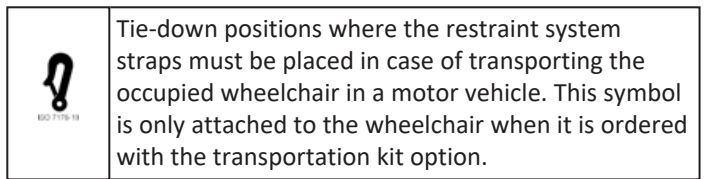

Anti-tip Device Warning Label

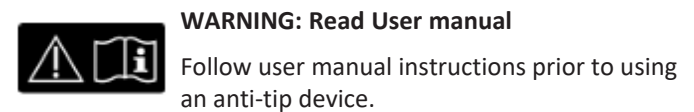

Suspension Warning Label

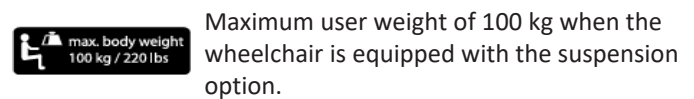

3 Product Overview

3.1 Product description

The Kuschall K-Series is a rigid frame active wheelchair with folding backrest.

! NOTICE!

The wheelchair is manufactured and configured individually to the specifications in the order. The specification must be performed by a healthcare professional/ clinician according to the occupant's requirements and health condition.

- Consult a healthcare professional if you intend to adapt the wheelchair configuration.
- Any adaptation should be performed by a qualified technician.

3.2 Intended use

The wheelchair may be used indoors and outdoors on level ground and accessible terrain.

The wheelchair is intended to provide mobility to persons limited to a sitting position, who are propelling the wheelchair themselves most of the time.

The wheelchair is not intended for abusive or excessive activities, such as sports, that are not part of the intended (daily) use.

Intended user

The wheelchair is intended for persons, ages 12 and up (adolescents and adults). The weight of the wheelchair occupant should not exceed the maximum user weight as stated in the Technical Data section and on the identification label.

The intended user is the wheelchair occupant and/or an assistant. The user should physically and mentally be able to use the wheelchair safely (e.g. to propel, steer, brake).

Indications

- Considerable to complete impairment of mobility due to structural and/or functional damage to the lower extremities.
- Sufficient strength and gripping function of arms and hands to propel the wheelchair.

Contraindications

There are no contra-indications known, when using the wheelchair as intended.

3.3 Main parts of the wheelchair

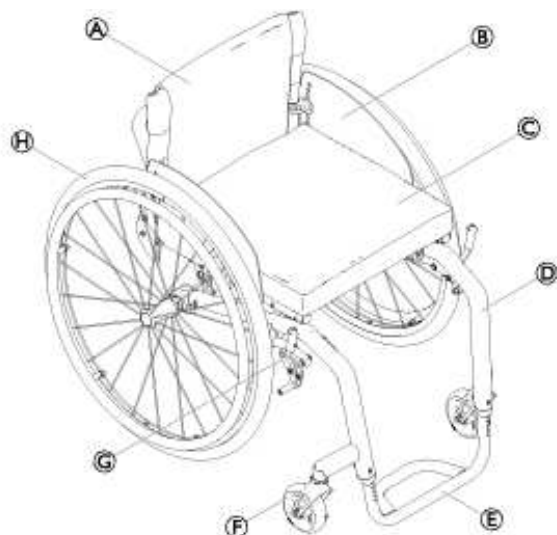

Ⓐ	Backrest
Ⓑ	Clothes-guard
Ⓒ	Seat with cushion
Ⓓ	Frame
Ⓔ	Footrest
Ⓕ	Castor fork with castor wheel
Ⓖ	Parking brake
Ⓗ	Rear wheel with handrim and quick-axle



The equipment of your wheelchair may differ from the diagram as each wheelchair is manufactured individually to the specifications in the order.

3.4 Parking brakes

The parking brakes are used to immobilize the wheelchair when it is stationary to prevent it from rolling away.

**WARNING!****Risk of overturning if you brake sharply**

If you engage the parking brakes while you are moving, the direction of movement can become uncontrollable and the wheelchair may stop suddenly, which can lead to a collision or to you falling out

- Never engage the parking brakes while you are moving.

**WARNING!****Risk due to wheelchair being out of control**

- The parking brakes must be operated simultaneously.
- Do not engage the parking brakes to slow down the wheelchair.
- Do not lean on the parking brakes for support or transfer.

**WARNING!****Risk of overturning**

- The parking brakes will not operate correctly unless there is sufficient air in the tyres. Ensure the correct tyre pressure, *11.2 Tyres, page 252*.

**CAUTION!****Risk of pinching or crushing**

There may be a very small gap between the rear wheel or the armrest front socket and the parking brake with the risk that you could trap your fingers.

- Keep your fingers away from movable parts when using the brake, always keep your hand on the brake lever.



The distance between the brake shoe and the tyre can be adjusted. The adjustment must be carried out by a qualified technician.

Standard brake

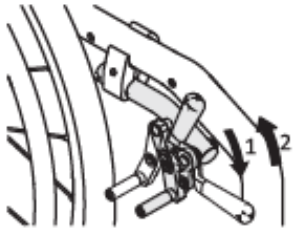

1. To engage the brake, push the brake lever forwards with the palm as far as possible.
2. To disengage the brake, pull the brake lever backwards with the low fingers.

 The lever of the push handle can be folded back to facilitate transfers. To do so, pull up the lever and fold it backwards.

Performance brake

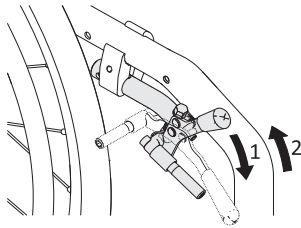

1. To engage the brake, push the brake lever forwards with the palm as far as possible.
2. To disengage the brake, pull the brake lever backwards with the low fingers.

Active brake

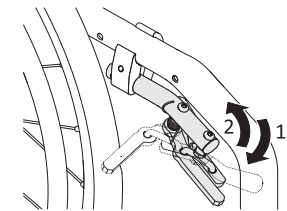

1. To engage the brake, pull the brake lever forwards beside or between your knees as far as possible.
2. To disengage the brake, push the brake lever backwards beside or between your knees.

Light active brake

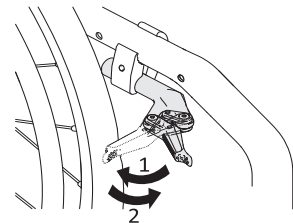

CAUTION!

Risk of pinching or crushing

Do not grasp the brake mechanism with the full hand when engage or disengage the brake.

1. To engage the brake, pull the brake lever backwards with the palm against the tyre as far as possible.
2. To disengage the brake, push the brake lever forwards with the hand edge.



The hardness of the locking/unlocking can be adapted to your needs. This adjustment must be carried out by a qualified technician

3.5 Backrest



WARNING!

Risk of injury to the assistant and damage to the wheelchair

Tilting the chair with a heavy occupant can hurt the assistant's back and damage the chair.

- Make sure to be able to safely control the wheelchair with a heavy occupant before performing a tilting maneuver.

3.5.1 Standard backrest cover



A standard backrest cover is available for all backrest types. These covers are not adjustable.



WARNING!

Risk of tipping

If the standard backrest cover become slack, the tipping point of your wheelchair is changed for the worse.

- Slack standard backrest cover must be replaced by a qualified technician.

In addition to the standard backrest cover, there are tension-adjustable backrest covers available.

3.5.2 Adjusting the tension of the backrest cover

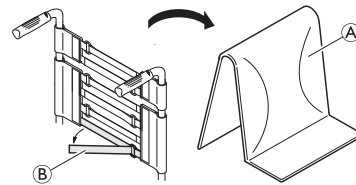

1. Remove the backrest cushion A.
2. Loosen the hook-and-loop straps B on the rear of the backrest cover by simply pulling on them.
3. Tighten or loosen the bands as required then reattach them.



WARNING!

Risk of tipping

If the bands are set very loose, the tipping point of your wheelchair is changed for the worse.

- Ensure with your healthcare professional that the bands are set correctly.

3.5.3 Backrest height / backrest angle

The height and the angle of the backrest can be adjusted. The adjustment must be carried out by a qualified technician.

**WARNING!****Risk of tipping**

The hanging of additional load (back pack or similar items) onto your wheelchair back posts can affect the rearward stability of your wheelchair. This can cause the chair to tip backwards causing injury.

- Try to avoid putting additional load in the back of the wheelchair.
- We strongly recommend the use of anti-tip devices when using your back posts with additional load.

3.5.4 Push handles**NOTICE!**

- Always check the push handles before using the wheelchair, as to whether the hand grips are secure, cannot be turned and cannot be pulled off.

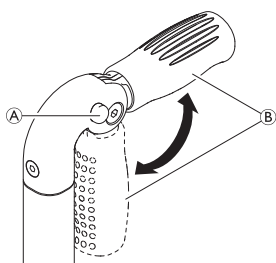
3.5.5 Foldable push handles

1. Fully depress button (A) and fold up respectively fold down the push handle (B) until it audibly engages.

**CAUTION!**

If not correctly engaged, the push handle could accidentally fold down while pushing the wheelchair.

- Make sure that the push handle is correctly engaged.

3.5.6 Height-adjustable push handles

The stepless height-adjustable push handles allow any assistant to adjust the handles to a comfortable level.

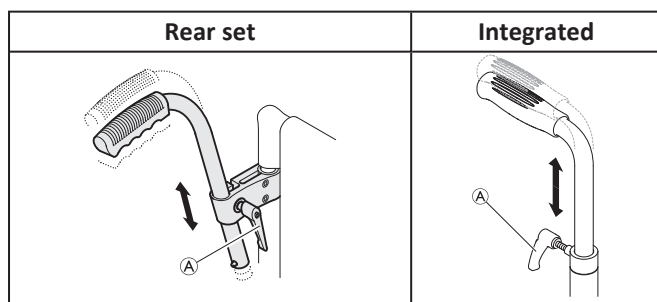
**WARNING!****Risk of injury**

- Do not use the height-adjustable push handles to pull the wheelchair.

3.6 Armrests and side parts**WARNING!****Risk of injury**

The side rests are not locked and can be easily pulled out upwards.

- Do not lift or transfer the wheelchair using the side rests.
- Do not use the side rests for transportation when carrying the wheelchair up- or downstairs.

**CAUTION!****Risk of pinching**

- Keep your fingers away from movable parts during removing, fitting or adjusting the armrest.

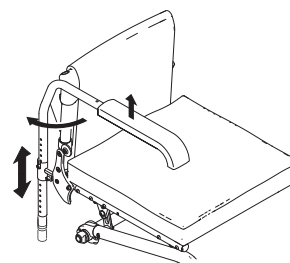
3.6.1 Tubular armrest, non-locking, height-adjustable, removable, swivelling**Removing**

1. Raise the armrest and pull it upwards out of the holder.

Installing

1. Push the armrest into the holder.

Adjusting the height

1. Pull the armrest out of the holder.
2. Loosen the screw on the tube of the armrest and screw it back in at the desired height.
3. Push the armrest back into the holder.
4. Perform the setting on both sides.

Swivelling

1. Slightly raise the armrest and swivel it outwards.

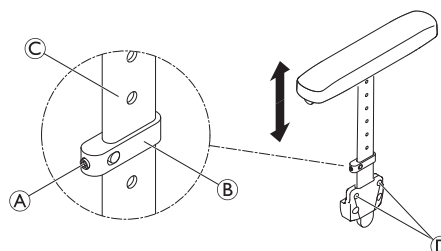
3.6.2 Side Rest, stepless height-adjustable, non-locking**Removing**

1. Pull the side rest by the arm cushion out of the holder.
2. To adjust how easy or difficult it is to pull the side rest out of the holder, change the degree to which the screws (D) are tightened.

Installing

1. Push the side rest into the holder.

Adjusting the height

1. Slightly loosen the grub screw (A) on the clamping part (B).
2. Move the clamping part upwards or downwards on the profile (C) to the desired height.
3. Re-tighten the grub screw.
4. Perform the setting on both sides.

3.6.3 Mudguard

In order to prevent dirt from the wheels spraying upwards, a removable mudguard can be fitted. The position of the mudguard can be adjusted. The adjustment must be carried out by a qualified technician.

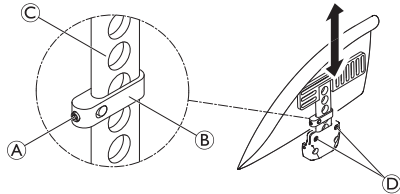

WARNING! Risk of injury

The mudguards are not locked and can be easily pulled out upwards.

- Do not lift or transfer the wheelchair using the mudguards.
- Do not use the mudguards for transportation when carrying the wheelchair up- or downstairs.

Removing

1. Pull the mudguard upwards out of the holder.
2. To adjust how easy or difficult it is to pull the mudguard out of the holder, change the degree to which the screws (D) are tightened.

Installing

1. Push the mudguard into the holder.

Adjusting the height

1. Slightly loosen the grub screw (A) on the clamping part (B).
2. Move the clamping part upwards or downwards on the profile (C) to the desired height.
3. Re-tighten the grub screw.
4. Perform the setting on both sides.

3.6.4 Clothes-guard

A clothes-guard can be installed to protect your clothes. Before folding the back of the wheelchair, the clothes-guard must first be folded inwards against the backrest.

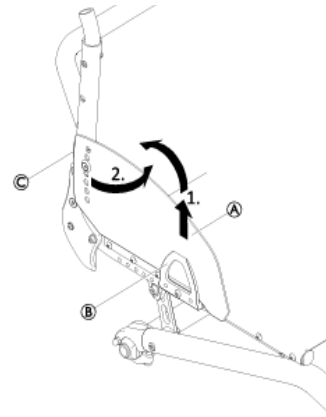

Folding in

1. Raise the clothes-guard (A) at the front out of the holder (B). Swivel it inwards around the joint (C) in front of backrest.

3.7 Calf strap

A calf strap is installed to the wheelchair to provide a better position of the users' legs.

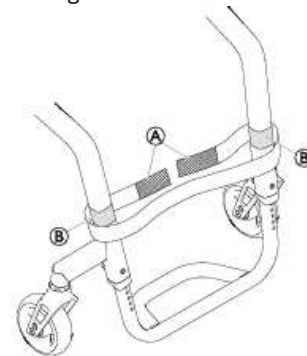

Installing / adjusting the calf strap

1. Install and adjust the calf strap (A) around the hook and loop fasteners (B) on both frame parts (1)



The calf strap can also be installed to the castor supporters by a qualified technician (2).

3.8 Rear wheel extension

Your wheelchair can be fitted with a rear wheel extension. The rear wheel extension makes it possible to alter the position of the rear wheel and thus the tipping stability of the wheelchair. The adjustment must be carried out by a qualified technician.



WARNING!
Risk of injury

If anti-tip devices are installed, check their settings each time the rear wheel position is changed and let them be adjusted by a qualified technician if necessary.

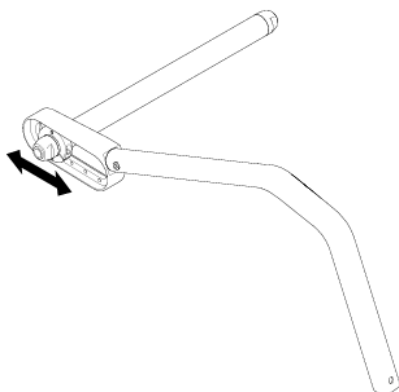

3.9 Vario-Ax

Your wheelchair can be fitted with a Vario-Ax. The Vario-Ax enables you to modify the wheel camber.

If anti-tip devices are installed, check their settings each time the rear wheel position is changed and let them be adjusted by a qualified technician if necessary.

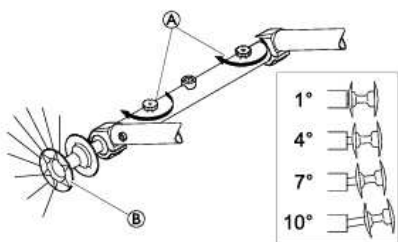

Adjusting wheel camber of the Vario-Ax



NOTICE!

- Do not over-tighten the knurled screw A as this can damage its mechanism.



NOTICE!

- Changing the wheel camber can impair or negate the function of the parking brakes.

1. Loosen the knurled screw (A) on the Vario-Ax.
2. Pull the wheel by the hub (B) until the desired angle is set.
3. A gentle engagement will indicate when it has reached one of the four possible positions.
4. Re-tighten the knurled screw (A).
5. Perform the same setting on both sides.

3.10 Seat cushion

A suitable cushion is recommended to provide an even pressure distribution on the seat.



CAUTION!

Risk of instability

Adding a cushion to the seat will raise your height above the ground and can affect your stability in all directions. If a cushion is changed it may also change the user's stability.

- If the thickness of the cushion is changed, a complete set up of the wheelchair need to be done by a qualified technician.
- We recommend using an Invacare or Matrix cushion with anti-slip base cover in order to prevent sliding.



Use a seat cushion with anti-slip underlay or hook fastening tapes to avoid slipping of the seat cushion. A loop fastening tape is pre-attached to the seat cover.

4 Options

4.1 Anti-tip device

An anti-tip device prevents the wheelchair from tipping backwards.



WARNING!

Risk of overturning

Incorrectly set or not working anti-tip devices can lead to overturning.

- Always check that the anti-tip device can lead to overturning. is working before using the wheelchair and have it set or readjusted by a qualified technician when required.
- In some configurations, the static stability of the wheelchair may be lower than 10°; Invacare strongly recommends the use of anti-tip device (available as an option).



WARNING!

Risk of overturning

On uneven or soft ground, the anti-tip device can sink into potholes or directly into the ground, thereby curtailing or eliminating its safety function.

- Only use the anti-tip device when traveling on even and firm ground.



NOTICE!

Risk of damage

- Never step on the anti-tip device or use it as a tipping aid.

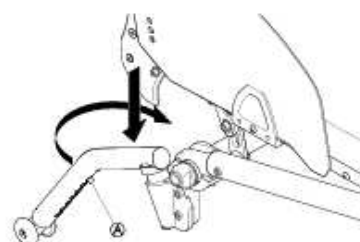

Activating the anti-tip device

1. Push the anti-tip device completely downwards against the spring and swivel it inwards through 90° until it engages.



WARNING!
Risk of tipping

If the wheelchair is equipped with a retractable anti-tip, it must always remain in the active position for user safety.

- It can be temporarily deactivated to overcome an obstacle that it cannot pass if it is in an active position
- Never leave a user alone in their wheelchair with the anti-tip device deactivated.

Deactivating the anti-tip device

1. Push the anti-tip device completely down (spring loaded) and swivel it through 90° until it engages.

Setting the position

1. Press the spring pin (A) on the anti-tip device and push the inner section to the position required. Allow the spring pin to engage in the nearest hole.



If further adjustments of height and/or position are necessary, refer to a qualified technician.

4.2 Posture belt

The wheelchair can be equipped with a posture belt. It prevents the user from sliding downward in the wheelchair or from falling out of the wheelchair. The posture belt is not a positioning device.



WARNING!
Risk of serious injury / strangulation

A loose belt can cause the user to slip down and create a risk of strangulation.

- The posture belt should be mounted by a qualified technician and fitted by a healthcare professional.
- Always make sure that the posture belt is tightly fitted across the lower pelvis.
- Each time the posture belt is used, check if it fits properly. Changing the seat and / or backrest angle, the cushion and even your clothes influence the fit of the belt.

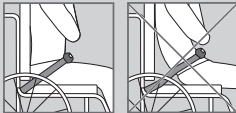

Closing and opening the posture belt

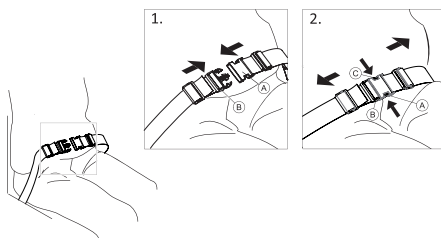

A suitable cushion is recommended to provide an even pressure distribution on the seat.

1. To close, push the catch (A) into the buckle clasp (B).
2. To open, push the PRESS button (C) and pull the catch (A) out of the buckle clasp (B).

Adjusting the length

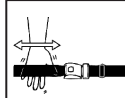

The posture belt has the good length, when there's just sufficient space for a flat hand between body and belt.

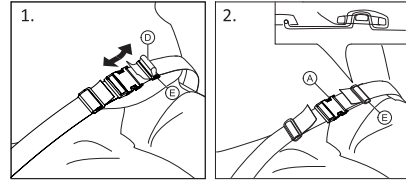

1. Shorten or extend the loop (D) as required.
2. Thread loop (D) through catch (A) and plastic buckle (E) until the loop is flat.
3. Ensure loop (D) is perfectly fitted in plastic buckle (E).
4. Secure adjustment with the strap extremity fitted in the buckle (E).



WARNING!
Risk of sliding and strangulation
Risk of falling

- Perform the adjustments on both sides equally, so that the buckle clasp remains in a central position.
- Ensure that both strap extremities are threaded two times into the buckle (E) to avoid the belt from loosening.
- Make sure that the belts do not get caught in the spokes of a rear wheel.

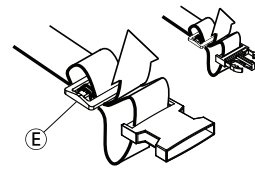

4.3 Attachment when using positioning belt



CAUTION!
Risk of sliding

- The belt must be placed tight to the body.
- If the length of the belt has been adjusted to fit one type of seat cushion height, it is important that this cushion is used. If the seat cushion is replaced, the length of the belt needs to be adjusted.



Positioning belts which are CE-marked for the purpose of using on wheelchairs, can be mounted on the chair with preserved CE-marking. The positioning belt should be fitted by a healthcare professional and be mounted by a qualified technician.



The purpose of using a belt for positional, is to position the user and to give him / her a better posture.

4.4 Transit wheels

If your wheelchair is too wide for certain applications, e.g. trains / aeroplanes, narrow passageways, narrow doors, the transit wheels can be used.



WARNING! Risk of severe accidents

When using transit wheels, the parking brakes no longer have any effect and you cannot control your wheelchair via the handrims.

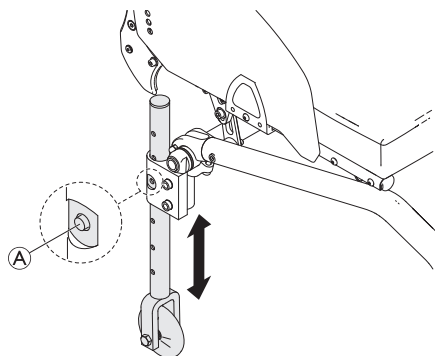

Switching to transit wheels

1. Lower transit wheels into the operating position. For this, press the pin **A** inwards until you can pull the tube down.
2. Press the second pin in.
3. Pull the tube further downwards until the pin engages into the slot.
4. Move the wheelchair to a stable object (door frame, heavy table), which you can use for support and hold onto it firmly with one hand.
5. Tilt the wheelchair until the rear wheel on the opposite side rises off the floor.



Prior to removing the rear wheels, the distance between the lowered transit wheels and the floor should not be more than 2 cm.

6. Remove the rear wheel → 7.3 *Removing and fitting the rear wheels, page 20*.
7. Repeat the process on the other side.

Switching from transit wheels to rear wheels

1. Move the wheelchair to a stable object, which you can use for support and hold onto it firmly with one hand.
2. Tilt the wheelchair until the transit wheel on the opposite side rises slightly off the floor.
3. Install the rear wheel back onto the removable axle → 7.3 *Removing and fitting the rear wheels, page 20*
4. Bring the transit wheels back into the inactive position.
5. Repeat the process on the other side.

4.5 Cane holder

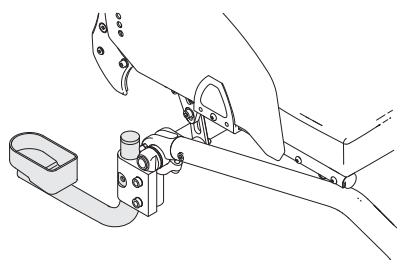

WARNING! Risk of overturning

- Ensure that the cane holder does not project beyond the external diameter of the rear wheel.



NOTICE! Risk of damage

- Never step on the cane holder or use it as a tipping aid.

1. Place the cane in the holder.
2. Fix the top of the cane to the backrest

4.6 Tipper aid

With the tipper aid, an assistant can tip the wheelchair more easily, in order to navigate steps for example.

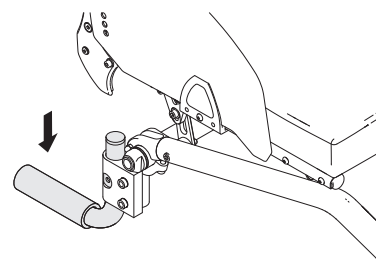

WARNING! Risk of overturning

- Ensure that the tipper aid does not project beyond the external diameter of the rear wheel.

1. Hold the wheelchair by the push handles.
2. Press the tipper aid with your foot and hold the wheelchair in the tipped position until you have overcome the obstacle.

4.7 Suspension



WARNING! Risk of injury

If a suspension is installed the wheelchairs center of gravity will change and there is a higher risk of tipping backwards.

- Make sure that the mudguard is adjusted correctly to avoid finger entrapment between the mudguard and the rear wheel. If necessary contact a qualified technician.
- Never change the suspension setting. Always refer to a qualified technician for adjustments.

4.8 Passive Illumination

You can attach reflectors to the rear wheels.

5 Setup

5.1 Safety Information



CAUTION! Risk of injury

- Before using the wheelchair, check its general condition and its main functions in 8.2 *Maintenance schedule, page 20*

Your provider will supply your wheelchair ready for use. Your provider will explain the main functions and ensure that the wheelchair meets your needs and requirements.

Adjustments of the axle position and the castor supporters must be carried out by a qualified technician.

6 Using the wheelchair

6.1 Safety Information



WARNING!
Risk of accidents

Uneven tyre pressure can have a huge effect on handling.

- Check the tyre pressure before each journey.



WARNING!
Risk of falling out of the wheelchair

When using front wheels that are too small, the wheelchair could get stuck at curbs or in floor grooves.

- Make sure that the front wheels are suitable for the surface you're driving on.



CAUTION!
Risk of crushing

There may be a very small gap between the rear wheel and the mudguard or armpad with the risk that you could trap your fingers.

- Ensure that you always propel your wheelchair using the handrims only.

Theft and metal detection systems

In seldom cases the materials used in the wheelchair may activate theft and metal detection systems.

6.2 Braking during use

Whilst you are moving, you brake by transferring force to the handrim with your hands.



WARNING!
Risk of accidents

If you engage the parking brakes while you are moving, the direction of movement can become uncontrollable and the wheelchair may stop suddenly, which can lead to a collision or to you falling out.

- Never engage the parking brakes while you are moving.



WARNING!
Risk of accident

- Always use the parking brakes to secure the wheelchair during short or long stops.



CAUTION!
Risk of burning your hands

If you brake for a long time, a lot of frictional heat is produced at the handrims (especially anti slip handrims)

- Wear suitable gloves.

1. Hold the handrims and press evenly with both hands until the wheelchair stops.

Braking with an attendant

With an attendant's brake (drum brake) an attendant can brake the wheelchair while it is moving. The attendant's brake can also be used as a parking brake

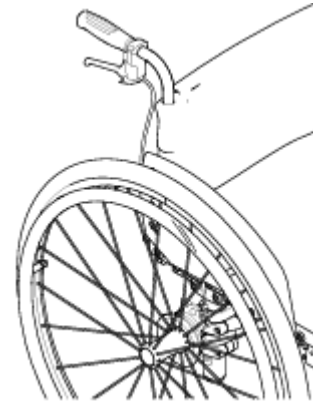

1. To brake, pull the brake lever on the push handle.
2. To park, pull the brake lever firmly and move the safety lever upwards.
3. To release, pull the brake lever until the safety lever disengages.

6.3 Getting in and out of the wheelchair



WARNING!
Risk of overturning

There is a high risk of overturning during the transfer.

- Only get in and out without assistance if you are physically able to do so.
- When transferring, position yourself as far back as possible in the seat. This will prevent damaged upholstery and the possibility of the wheelchair tipping forward.
- Make sure that both castors are facing straight to the front.



WARNING!
Risk of overturning

The wheelchair could tip forwards if you stand on the footrest.

- Never stand on the footrest when getting in and out.



CAUTION!

A heavy load hanging on the backrest can affect the wheelchair's centre of gravity.

- Change your driving style accordingly.



CAUTION!

If you disengage or damage the brakes the wheelchair could roll away out of control.

- Do not support yourself on the brakes when getting in and out.

- ! NOTICE!**
The mudguards and armrests could become damaged.
- Never sit on the mudguards or armrests when getting in and out.



1. Propel the wheelchair as near as possible to the seat that you want to move to.
2. Engage the parking brakes.
3. Remove the armrests or move them upwards out of the way.
4. Detach the leg rests or swing them outwards.
5. Place your feet on the ground.
6. Hold the wheelchair and, if necessary, also hold a fixed object in the vicinity.
7. Move slowly to chair.

6.4 Driving and steering the wheelchair

You drive and steer the wheelchair using the handrims. Before driving without an assistant you must find your wheelchair's tipping point.



WARNING! **Risk of tipping**

- The wheelchair can tip backwards.
- When finding the tipping point, an assistant must stand immediately behind the wheelchair to catch it if it tips over.
 - To prevent tipping, install an anti-tip device.



WARNING! **Risk of tipping**

- The wheelchair can tip forward.
- When setting up your wheelchair, test its behaviour in terms of tipping forward and adjust your driving style accordingly.

Finding the tipping point

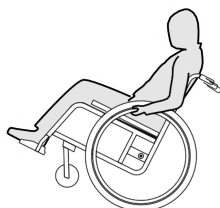

1. Release the brake.
2. Roll backwards a short distance, grasp both handrims firmly and push forwards with a slight kick.
3. The shift in weight and steering in opposite directions with the handrims will enable you to identify the tipping point.

6.5 Negotiating steps and kerbs



WARNING!

Risk of overturning

- When negotiating steps you could lose your balance and tip the wheelchair over.
- Always approach steps and kerbs slowly and carefully.
 - Do not go up or down steps that are higher than 25 cm.



CAUTION!

- An activated anti-tip device prevents the wheelchair from tipping backwards.
- Deactivate the anti-tip device before going up or down steps or kerbs.



WARNING!

Risk of injury to the assistant and damage to the wheelchair

- Tilting the chair with a heavy user can hurt the assistant's back and damage the chair.
- Make sure to be able to safely control the wheelchair with a heavy user before performing a tilting maneuver.

Going down a step with an assistant



1. Move the wheelchair right up to the kerb and hold the handrims.
2. The assistant should hold both push handles, place one foot on the tipper aid (if installed) and tilt the wheelchair backwards so that the front wheels lift off the ground.
3. The assistant should then hold the wheelchair in this position, push it carefully down the step and then tilt it forwards until the front wheels are back on the ground.

Going up a step with an assistant



WARNING!

Risk of serious injuries

- Going up steps and kerbs often than the normal use can cause a fatigue break of the wheelchair backrest and the user might fall out of the wheelchair.
- Make sure that the wheelchair can be controlled by the user or the assistant before performing a tilting maneuver.

1. Move the wheelchair backwards until the rear wheels touch the kerb.
2. The assistant should tilt the wheelchair using both push handles so that the front wheels lift off the ground, then pull the rear wheels over the kerb until the front wheels can be placed back on the ground.

Going down a step without an assistant

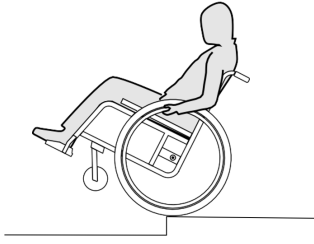

WARNING! Risk of tipping

When going down a step without an assistant you could tip over if you cannot control your wheelchair.

- First learn how to go down a step with an assistant.
- Learn how finding the tipping point to balance on the rear wheels, *6.4 Driving and steering the wheelchair*, page 15

1. Move the wheelchair right to the kerb, lift the front wheels and keep the wheelchair balanced.
2. Now slowly roll both rear wheels over the kerb. While doing this, hold the handrims firmly with both hands until the front wheels are back on the ground.

6.6 Going up and down stairs



WARNING! Risk of overturning

When negotiating stairs you could lose your balance and overturn your wheelchair.

- Always use two assistants when negotiating stairs with more than one step.



1. You can go up and down stairs by taking them one step at a time, as described above. The first assistant should stand behind the wheelchair holding the push handles. The second assistant should hold a solid part of the front frame to steady the wheelchair from the front.

6.7 Negotiating ramps and slopes



WARNING! Risk due to wheelchair being out of control

When negotiating slopes or gradients your wheelchair could tip backwards, forwards or sideways.

- Always have an assistant behind the wheelchair when approaching long slopes.
- Avoid lateral slopes.
- Avoid slopes of more than 7°.
- Avoid jerking when changing direction on a slope.



CAUTION!

Your wheelchair could run away even on slightly sloping ground if you do not control it using the handrims.

- Use the parking brakes if your wheelchair is stationary on sloping ground.

Going up slopes

To go up a slope, you must create some momentum, keep up the momentum and control the direction at the same time.

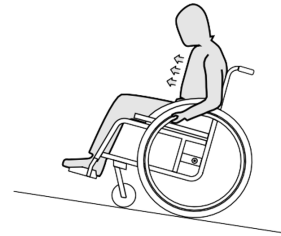

1. Bend your upper body forwards and propel the wheelchair with quick, powerful strokes on both handrims.

Going down slopes

When going down slopes, it is important to control your direction and particularly your speed.

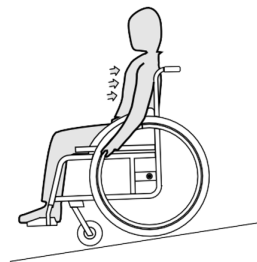

1. Lean back and carefully allow the handrims to run through your hands. You should be able to stop the wheelchair at any time by gripping the handrims.



CAUTION! Risk of burning your hands

If you brake for a long time, a lot of frictional heat is produced at the handrims.

- Wear suitable gloves.

6.8 Stability and balance when seated

Some everyday activities and actions require you to lean forwards, sideways or backwards out of the wheelchair. This has a major effect on the wheelchair's stability. To keep your balance at all times, proceed as follows:

Leaning forwards



WARNING! Risk of falling

If you lean forwards out of the wheelchair you could fall out of it.

- Never bend too far forwards and do not shift forwards in your seat to reach an object.
- Do not bend forwards between your knees to pick up something off the floor



1. Point the front wheels forwards. (To do this, move your wheelchair forwards slightly then back again.)
2. Apply both parking brakes.
3. When leaning forwards your upper body must remain over the front wheels.

Reaching backwards



WARNING! Risk of falling

If you lean too far backwards you could tip your wheelchair over.

- Do not lean out over the backrest.
- Use an anti-tip device.

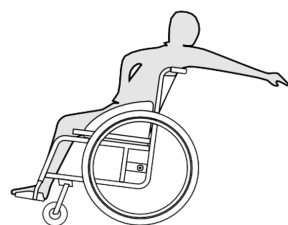

1. Point the front wheels forwards. (To do this, move your wheelchair forwards slightly then back again.)
2. Do not apply the parking brakes.
3. When reaching backwards do not reach so far that you have to change your sitting position.

6.9 Transporting the manual wheelchair without occupant



CAUTION! Risk of burning your hands

If you brake for a long time, a lot of frictional heat is produced at the handrims (especially anti slip handrims).

- Wear suitable gloves.

Your manual wheelchair may be transported without restrictions, whether by road, rail or by air. Individual transport companies have, however, guidelines which can possibly restrict or forbid certain transport procedures. Please ask the transport company regarding each individual case.

- Invacare strongly recommends securing the manual wheelchair to the floor of the transporting vehicle.

6.10 Transporting the occupied wheelchair in a vehicle

Even when the wheelchair is properly secured and the following rules are met, injuries to passengers may occur in a collision or sudden stop. Therefore Invacare strongly recommends transferring the wheelchair user to the vehicle seat with the 3-point passenger restraint system on.

Do not make alterations or substitutions to points of the wheelchair (structure, frame or parts) without the written consent of Invacare. The wheelchair has been successfully tested according to the requirements of ISO 7176-19 (Frontal impact).



WARNING! Risk of serious injury or death

To use the wheelchair as a seat in a vehicle the backrest height minimum must be at least 400 mm.

To transport the wheelchair with user in a vehicle, a restraint system must be installed in the vehicle. Wheelchair tie-downs and occupant restraint systems must be approved according to ISO 10542-1.

Contact your local Invacare authorized provider for more information on getting and installing an approved and compatible restraint system.



WARNING!

If, for some reason, it is impossible to transfer the wheelchair user to a vehicle seat, the wheelchair can be used as a seat in a vehicle if the following procedures and regulations are followed. A transportation kit (optional) have to be fitted on the chair for such a purpose.

- The wheelchair must be secured in the vehicle with a 4-point wheelchair restraint system.
- The user must wear a 3-point passenger restraint system secured to the vehicle.
- The user can be additionally secured with a posture belt in the wheelchair.



WARNING!

Safety restraint devices must only be used when the wheelchair user's weight is 22 kg or more (ISO-7176-19).

- Do not use the wheelchair as a seat in a vehicle when the user weight is lower than 22 kg.



WARNING!

- Before journey contact transporter and request information about the capability for the below required equipment.
- Make sure there is sufficient free space around the wheelchair and user to avoid the user making contact with other vehicle occupants, unpadded parts of the vehicle, wheelchair options or anchor points of the restraint system.



WARNING!

- Make sure the tie-down points at the wheelchair are not damaged and that the parking brakes are fully functional.
- It's recommended to use puncture-proof tyres during transport to avoid brake problems due to reduced tyre pressure.



WARNING!

- Injury or damage may occur from wheelchair components or options loosened during a collision or sudden stop.
- Ensure all removable or detachable components and options are removed from the wheelchair and securely stored in the vehicle.
 - It is essential to have your wheelchair checked by a qualified technician after an accident, collision etc.



We strongly recommend transferring the wheelchair user to the vehicle with the posture belt on.



NOTICE!

- Refer to the user manuals supplied with the restraint systems.
- The following illustrations may differ depending on the restraint system supplier.



The choice of wheelchair configuration (seat width and depth, wheelbase) influences maneuverability and access to motor vehicles.

Securing the wheelchair with a 4-point restraint system

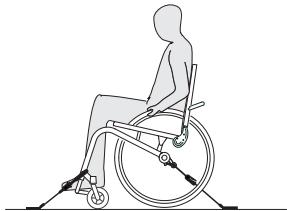

WARNING!

- Place the wheelchair with the user forward-facing in direction of vehicle travel.
- Engage the wheelchair parking brakes.
- Activate the anti-tip device (if installed).

The wheelchair tie-down positions where the 4-point restraint system straps must be placed are marked with snap hook symbols, see following figures and section .

1. Using the front and rear straps of the 4-point restraint system, secure the wheelchair to the vehicle mounted rails. Refer to the user manual supplied with 4-point restraint system.

Front side tie-down positions for belt straps:



WARNING!

Risk of chassis damage

- Snap hooks are not compatible with the K-Series frame.
- Always use a strap around the castor supporter. Contact your provider of restraint system to get resistant straps.
 - If needed you can use your snap hooks in the loops of the straps (see illustration below).

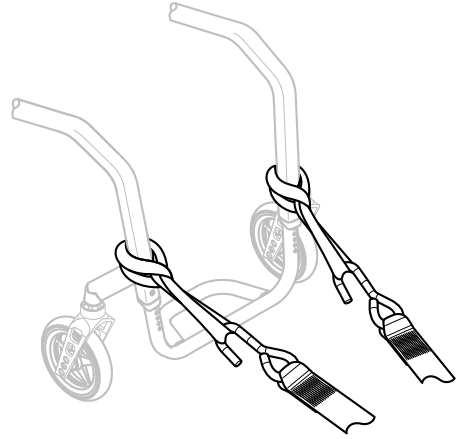

1. Attach the front straps above the castor supporters as shown above (see location of the attachment labels).
2. Attach front straps to the rail system referring to best practice recommended instructions from the safety belt manufacturer.
3. Release the parking brakes and apply tension front straps by pulling the wheelchair backwards from the rear.
4. Readjust the parking brakes.

Rear side tie-down positions for snap hooks:

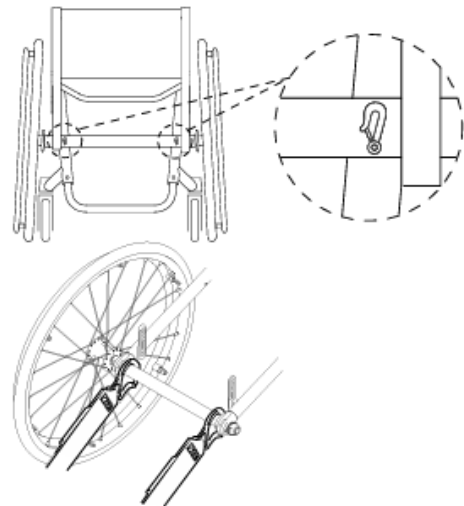

1. Attach rear straps to the rail system referring to best practice recommended instructions from the safety belt manufacturer.
2. Tighten the straps.



NOTICE!

- Make sure that the snap hooks are covered with slip resistant material to avoid laterally slipping on the axle.

- ! NOTICE!**
- Check the plungers are fully engaged on both sides and located in the same position of the cut-out section of the rail.
 - Make sure that the angle between the rails and the straps lies between 40° and 45°.

Fit posture belt



WARNING!

- The posture belt can be used in addition to but never as a substitute for an approved 3-point passenger restraint system.

1. Adjust posture belt to fit the wheelchair occupant, see section 1 *Posture belt*, page 1.

Fastening the 3-point passenger restraint system

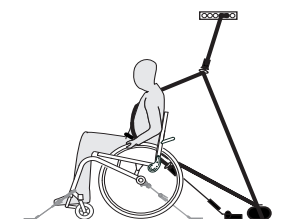

! NOTICE!

- The illustration above may differ depending on the restraint system supplier.



WARNING!

- Ensure the 3-point passenger restraint system fits as tightly across the user's body as possible without discomfort and no part is twisted.
- Ensure the 3-point passenger restraint system is not held away from the user's body by parts of the wheelchair such as armrests or wheels etc.
- Ensure the 3-point passenger restraint system has a clear path from the user to the anchor point without interference by any part of the vehicle, wheelchair, seating or option.
- Ensure the pelvic belt fits snugly over the occupant's pelvis and is not allowed to ride up into the abdominal area.
- Ensure the user is able to reach the release mechanism unaided.

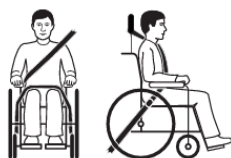

1. The 3-point belt restraint should fit as tightly across the user's body as possible without discomfort.

! NOTICE!

- Ensure that the belt webbing is not twisted when in use.

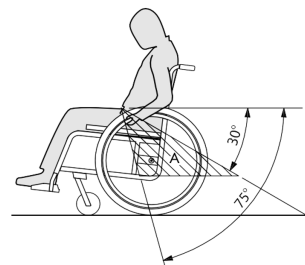

! NOTICE!

- Apply the pelvic belt of the 3-point passenger restraint system low across the pelvis so that the angle of the pelvic belt is within the preferred zone Ⓐ of 30° to 75° to the horizontal. A steeper angle is preferred, but never exceeding 75°.



The image shows an incorrect placement of three-point belt restraint.

2. The belt restraint must not be held away from the user's body by parts of the wheelchair such as armrests or wheels etc.
3. If the vehicle is equipped with a head restraint and the wheelchair with the head/neck support, then assess with a clinician which one should be used.



The Invacare head and neck supports are not restraint devices. Nevertheless, they have been crash tested to verify their attachment points.

7 Transport

7.1 Safety information



WARNING!

Risk of injury if the wheelchair is not properly secured

In the event of an accident, braking maneuver, etc. you may suffer serious injuries from flying wheelchair parts.

- Always remove the rear wheels when transporting the wheelchair.
- Firmly secure all wheelchair components in the means of transport to prevent them from coming loose during the journey.
- When transporting the unoccupied wheelchair in a car or an airplane make sure that it is folded and secured.

! NOTICE!

Excessive wear and abrasion could affect the strength of load-bearing parts.

- Do not pull your wheelchair across abrasive surfaces without the wheels fitted (e.g. pulling the frame over tarmac).

7.2 Folding and unfolding the backrest

Folding the backrest

1. Remove the seat cushion, if present.
2. Slightly raise and fold the clothes-guard, if present, inwards against the backrest on both sides.
3. Pull the cord on the back of the wheelchair and fold the backrest forward until it engages.
4. The wheelchair can now be lifted using the backrest bar.

Unfolding the backrest

! NOTICE!

- Do not pull the backrest brace without previously releasing the backrest using the cord.
- Check that the backrest is completely engaged on the frame, before you use the wheelchair again.

1. Pull the cord on the backrest of the wheelchair.
2. Pull the backrest backwards using the backrest brace, until the backrest tube engages on both sides of the frame.
3. Fold the clothes-guard back into position on both sides.

7.3 Removing and fitting the rear wheels



WARNING!
Risk of overturning

If the removable axle of a rear wheel is not fully engaged, the wheel can become loose during use. This can lead to overturning.

- Always ensure that the removable axles are fully engaged whenever you fit a wheel.

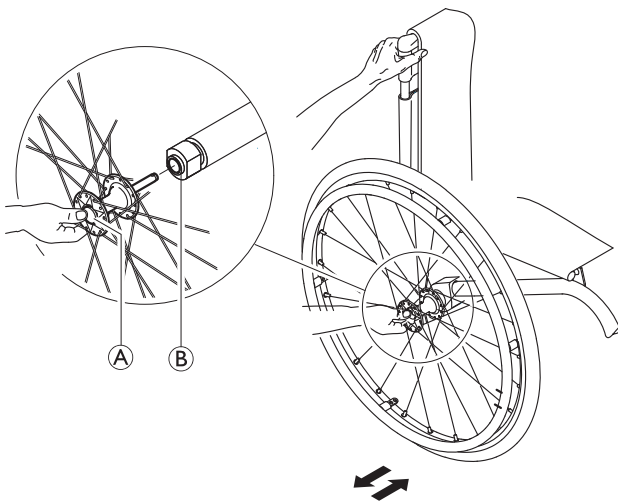

Removing the rear wheels

1. Disengage the wheel locks.
2. With one hand, hold the wheelchair upright.
3. With the other, hold the wheel through the external spoke rim around the wheel hub.
4. Using your thumb, press the removable axle button (A). Keep it pressed and pull the wheel out of the adapter sleeve (B).

Fitting the rear wheels

1. Disengage the wheel locks.
2. With one hand, hold the wheelchair upright.
3. With the other, hold the wheel through the external spoke rim around the wheel hub.
4. Using your thumb, press the removable axle button (A). Keep it pressed and pull the wheel out of the adapter sleeve (B).
5. Push the axle into the adapter sleeve (B) up to the stop.
6. Release the removable axle button and make sure that the wheel is secure.

8 Maintenance

8.1 Safety Information



WARNING!

Some materials deteriorate naturally over time.

This could result in damage to wheelchair components.

- Your wheelchair should be checked by a qualified technician at least once a year or if it has not been used for a long period.

8.2 Maintenance schedule

To ensure safe and reliable operation, carry out the following visual checks and maintenance regularly or have it carried out by another person.

	Weekly	Monthly	Annually
Check the tyre pressure	x		
Check that rear wheels are seated correctly	x		
Check the adjustment of the backrest joint	x		
Check posture belt	x		
Visual Check		x	
Check the folding mechanisms		x	
Check the castors and its fixation		x	
Check bolts		x	
Check spokes		x	
Check parking brakes (mechanism and cable)		x	
Have wheelchair checked by a qualified technician			x

Check the tyre pressure

1. Check the tyre pressure, see section "Tyres" for more information.
2. Inflate the tyres to the required pressure.
3. Check the tyre tread at the same time.
4. If necessary, change the tyres.

Check that rear wheels are seated correctly

1. Pull on the rear wheel to check that the removable axle is seated correctly. The wheel should not come off.
2. If the rear wheels are not engaged properly, remove any dirt or deposits. If the problem persists, have the removable axles re-fitted by a qualified technician.

Check the adjustment of the backrest joint

1. Sit into the wheelchair and lean back on the backrest. The backrest must be correctly engaged.
2. Pull the release cord. The pins must be free-moving on both sides. Otherwise, the backrest joint will have to be readjusted by your provider.

Check posture belt

1. Check that the posture belt is adjusted correctly.

- !** **NOTICE!**
- Loose posture belts must be adjusted by an authorized provider.
 - Damaged posture belts must be replaced by a qualified technician.

General visual check

1. Examine your wheelchair for loose parts, cracks or other defects.
2. If you find anything, stop using your wheelchair immediately and contact an authorized provider.

Check the castors and their fixations

1. Check that the castors turn freely.
2. Push and pull in the 3 directions (front and rear; left and right; up and down) to observe that there is no free play and movement, also check that there is no visual damage.

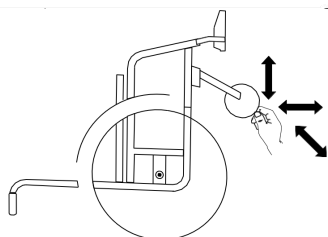

3. Remove any dirt or hair from the castor bearings.
4. Faulty or worn out castors fixation must be replaced by a qualified technician.

Check the bolts

Bolts can work loose through constant use.

1. Check that the bolts are tight (on the footrest, seat cover, sides, backrest, frame, seat module).
2. Tighten any loose bolts with the suitable torque. Therefore refer to the service manual, available on the internet at www.kuschall.com.

- !** **NOTICE!**
- Self-locking screws/nuts or thread-locking adhesive are used for several connections. If these are loosened, they must be replaced by new self-locking screws/nuts or they must be secured using new thread-locking adhesive.
- Self-locking screws/nuts must be replaced by a qualified technician

Check the spoke tension

1. The spokes should not be loose or distorted.
2. Broken spokes must be replaced by a qualified technician.
3. Loose spokes must be tightened by a qualified technician.

Check the parking brakes

1. Check that the parking brakes are positioned correctly. The brake is set correctly if the brake shoe depresses the tyre by a few millimetres when the brake is engaged.
2. If you find that the setting is not correct, have the brakes correctly adjusted by a qualified technician

- !** **NOTICE!**
- The parking brakes must be reset after replacing the rear wheels or changing their position.

Checking after a heavy collision or blow

- !** **NOTICE!**
- The wheelchair can sustain visibly undetectable damage as a result of a heavy collision or hard blow.
- It is essential to have your wheelchair checked by a qualified technician after a heavy collision or hard blow.

Repairing or changing an inner tube

1. Remove the rear wheel and release any air from the inner tube.
2. Lift one tyre wall away from the rim using a bicycle tyre lever. Do not use sharp objects such as a screwdriver which could damage the inner tube.
3. Pull the inner tube out of the tyre.
4. Repair the inner tube using a bicycle repair kit or, if necessary, replace the tube.
5. Inflate the tube slightly until it becomes round.
6. Insert the valve into the valve hole on the rim and place the tube inside the tyre (the tube should lie right round the tyre with no creases).
7. Lift the tyre wall over the edge of the rim. Start close to the valve and use a bicycle tyre lever. When doing this, check all the way round to ensure that the inner tube is not trapped between the tyre and the rim.
8. Inflate the tyre to the maximum operating pressure. Check that no air is escaping from the tyre.



Spare parts

All spare parts may be obtained from an Invacare authorized provider.

8.3 Cleaning and disinfection

8.3.1 General safety information



CAUTION!

Risk of contamination

Take precautions for yourself and use appropriate protective equipment.



NOTICE!

Wrong fluids or methods can harm or damage the product. All cleaning agents and disinfectants used must be effective, compatible with one another and must protect the materials they are used to clean.

- Never use corrosive fluids (alkalines, acid etc.) or abrasive cleaning agents. We recommend an ordinary household cleaning agent such as dishwashing liquid, if not specified otherwise in the cleaning instructions.
- Never use a solvent (cellulose thinner, acetone etc.) that changes the structure of the plastic or dissolves the attached labels.
- Always make sure that the product is completely dried before taking it into use again.



For cleaning and disinfection in clinical or long-term care environments, follow your in-house procedures.

8.3.2 Cleaning intervals



NOTICE!

Regular cleaning and disinfection enhance smooth operation, increases the service life and prevents contamination.

- Clean and disinfect the product:
 - Regularly while in use,
 - Before and after any service procedure,
 - When it has been in contact with any body fluids,
 - Before using it for a new user.

8.3.3 Cleaning



NOTICE!

- The product does not tolerate cleaning in automatic washing systems, with high-pressure cleaning equipment or steam.



NOTICE!

Dirt, sand and seawater can damage the bearings and steel parts can rust if the surface is damaged.

- Only expose the wheelchair to sand and sea water for short periods and clean it after every trip to the beach.
- If the wheelchair is dirty, wipe off the dirt as soon as possible with a damp cloth and dry it carefully.

1. Remove any options fitted (only options which do not require tools).
2. Wipe down the individual parts using a cloth or soft brush, ordinary household cleaning agents (pH = 6 - 8) and warm water.

3. Rinse the parts with warm water
4. Thoroughly dry the parts with a dry cloth.



Car polish and soft wax can be used on painted metal surfaces to remove abrasions and restore gloss.

Cleaning upholstery

For cleaning upholstery refer to the instructions on the labels of the seat, cushion and backrest cover.



If possible, always overlap hook and loop strips (the self-gripping parts) when washing, to minimize lint and thread build-up on hook strips and prevent damage to upholstery fabric by these.

8.3.4 Disinfection

The wheelchair may be disinfected by spraying or wiping with tested, approved disinfectants.



Spray a soft cleaning and disinfecting product (bactericidal and fungicide meeting the EN1040/ EN1276 / EN1650 standards) and follow the instructions given by the manufacturer.

1. Wipe down all generally accessible surfaces with a soft cloth and ordinary household disinfectant.
2. Allow the product to air-dry.

9 Troubleshooting

9.1 Safety information

Faults may arise as a result of daily use, adjustments or changing demands on the wheelchair. The table below shows how to identify and repair faults. Some of the actions listed must be carried out by a qualified technician. These are indicated. We recommend that all adjustments are carried out by a qualified technician.

CAUTION!

– If you notice a fault with your wheelchair, e.g. a significant change in handling, stop using your wheelchair immediately and contact your provider.

9.2 Identifying and repairing faults

Fault	Possible cause	Action
The wheelchair does not travel in a straight line	Incorrect tyre pressure on one rear wheel	Correct tyre pressure → <i>11.2 Tyres, page 25</i>
	One or more spokes broken	Replace faulty spoke(s) → qualified technician
	Spokes tightened unevenly	Tighten loose spokes → qualified technician
	Castor supporter is not aligned correctly	Correct position and alignment of the castor supporter, → qualified technician
	Castor bearings are dirty or damaged	Clean the bearings or replace the castor → qualified technician
	Rear wheels are off track	Change track → qualified technician
	Castors not adjusted to same height	Position the castors such that they touch the floor at the same time → qualified technician
The wheelchair tips backwards too easily	Rear wheels are mounted too far forwards	Mount the rear wheels further back → qualified technician
	Back angle too large	Reduce the backrest angle → qualified technician
Removable axles cannot be inserted correctly	Removable axles dirty	Clean removable axles
	Removable axles misaligned	Adjust removable axles → qualified technician
The parking brakes are gripping poorly or asymmetrically	Incorrect tyre pressure in one or both rear tyres	Correct tyre pressure → <i>11.2 Tyres, page 25</i>
	Brake setting incorrect	Correct the brake setting, → qualified technician
Rolling resistance is very high	Tyre pressure in rear tyres is too low	Correct tyre pressure → <i>11.2 Tyres, page 25</i>
	Tyre is punctured	
	Rear wheels not parallel	Ensure the rear wheels are parallel → qualified technician
The castors wobble when moving fast	Too little tension in castor bearing block	Tighten the nut on the bearing block axle slightly → qualified technician
	Castor has worn smooth	Change castor → qualified technician
The castor is stiff or stuck	Bearings are dirty or faulty	Clean or replace the bearings → qualified technician
The backrest is very difficult to unfold	Backrest cover is too tight	Loosen the hook-and-loop straps of the backrest cover a little → Correct tyre pressure → <i>11.2 Tyres, page 25</i>

10 After use

10.1 Storage

! **NOTICE!**
Risk of damage to the product

- Do not store the product near heat sources.
- Never store other items on top of the wheelchair.
- Store the wheelchair indoors in a dry environment.
- Refer to temperature limitation in section 11.4 *Environmental conditions*, page 26.

After long-term storage (more than four months) the wheelchair must be inspected in accordance to section 8.2 *Maintenance schedule*, page 20.

10.2 Reconditioning

This product is suitable for reuse. To recondition the product for a new user, carry out the following actions:

- Inspection
- Cleaning and disinfection
- Adaptation to the new user

For detailed information, please see section 8.2 *Maintenance schedule*, page 20 and the service manual for this product.

Make sure that the user manual is handed over with the product.

If any damage or malfunction is detected, do not reuse the product.

10.3 Disposal

Be environmentally responsible and recycle this product through your recycling facility at its end of life.

Disassemble the product and its components, so the different materials can be separated and recycled individually.

The disposal and recycling of used products and packaging must comply with the laws and regulations for waste handling in each country. Contact your local waste management company for more information.

11 Technical data

11.1 Dimensions and weights

All dimension and weight specifications refer to a wide range of the wheelchair in a standard configuration. Dimension and weight (based on ISO 7176–1/5/7) may alter according to different configurations. In some configurations, the wheelchair exceeds the recommended dimensions for a wheelchair.

- !** **NOTICE!**
- In some configurations, the overall dimensions of the wheelchair when it is ready for use exceeds the authorised limits and the access to emergency escape routes is not possible.
 - In some configurations, the wheelchair exceeds the size recommended for travelling by train in the EU.

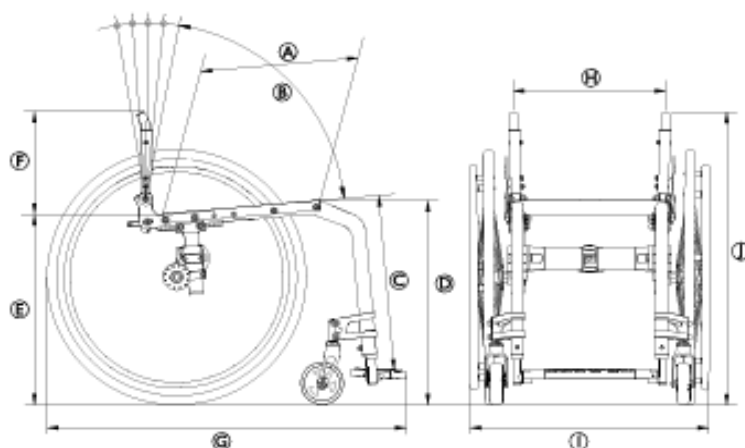

	Maximum load of the wheelchair (*)	130 kg 100 kg with the suspension option
Ⓐ	Seat depth	350 – 525 mm, in increments of 25 mm
Ⓑ	Backrest angle	74°/78°/82°/86°/90°/94°
Ⓒ	Lower leg length	290 – 480 mm, in increments of 10 mm
Ⓓ	Front seat-to-floor height	450 – 520 mm, in increments of 10 mm
Ⓔ	Rear seat-to-floor height	390 – 490 mm, in increments of 10 mm
Ⓕ	Backrest height	270 – 480 mm, in increments of 15 mm
Ⓖ	Overall length with legrest	75° frame angle: approx. 830 mm 90° frame angle: approx. 760 mm
Ⓗ	Seat width	320 – 500 mm, in increments of 20 mm
①	Overall width	approx. 490 – 805 mm
①	Overall height	approx. 650 – 1200 mm
	Folded height	approx. 600 – 710 mm
	Total weight	approx. 7.9 kg
	Weight of the heaviest part	5.3 kg
	Pivot width	1240 mm
	Minimum turning radius	700 mm
	Max. safe slope	7°
	Static stability downhill	20°
	Static stability uphill	7°
	Static stability sideways	20°
	Seat plane angle	0° – 20°
	Leg to seat surface angle	55° – 115°
	Armrest to seat distance	120 – 280 mm
	Front location of armrest structure	220 – 330 mm
	Handrim diameter	520 – 580 mm
	Horizontal location of axle	approx. –20 to +140 mm

(*) The maximum load of the wheelchair is the total of the maximum occupant mass and the maximum mass of any other items intended to be carried by the wheelchair.

The maximum occupant mass is the maximum load of the wheelchair without additional load.

Example for a wheelchair with a back pack of 10kg:

Maximum Occupant Mass = Maximum Load of the wheelchair = 10kg

11.2 Tyres

The ideal pressure depends on the tyre type:

Tyre	Diameter	Max. pressure		
		bar	kPa	psi
Profile tyre	610 mm (24")	7 bar	700 kPa	101 psi
Other tyres	610 mm (24"); 635 mm (25"); 660 mm (26")	10 bar	1000 kPa	145 psi

 The compatibility of the tyres listed above depends on the configuration and/or model of your wheelchair.

 In case of a tyre puncture consult a suitable workshop (e.g. bike repair shop, bicycle dealer ...) to have the tube replaced by a skilled person.

 The size of the tyre is mentioned on the sidewall of the tyre. The change of appropriate tyres must be carried out by a qualified technician.

**CAUTION!**

— The tyre pressure has to be equal in both wheels to avoid a less driving comfort, to keep the brakes efficiency and an easy propelling of the wheelchair.

11.3 Materials

Frame tubes	Aluminum / Carbon Fibre
Backrest tubes	Aluminum / Titanium
Axle tube	Aluminum / Carbon Fibre
Seat cover / Backrest cover	PA / PE / PVC
Push handles	Aluminum / TPE
Clothes guard / Mudguard	Carbon Fibre or Plastic
Castor forks	Aluminum
Footrest tube	Aluminum / Titanium
Footplate	Carbon Fibre or Plastic
Supporting parts / Attachments	Steel / Aluminum
Screws, washers and nuts	Steel

 All materials used are protected against corrosion. We use only REACH compliant materials and components.

 Theft and metal detection systems: in seldom cases the materials used in the wheelchair may activate theft and metal detection systems.

11.4 Environmental conditions

	Storage and transportation	Operation
Temperature	-20 °C to 40 °C	
Relative humidity	20 % to 90 % at 30 °C, not condensing	
Atmospheric pressure	800 hPa to 1060 hPa	

 Be aware that when a wheelchair has been stored under low temperatures, it must be adjusted before use. Please see *8 Maintenance, page 20*.



United Kingdom & Ireland:

Invacare Ltd.

Pencoed Technology Park, Pencoed

Bridgend CF35 5AQ

Tel: (44) (0) 1656 776 200

uk@invacare.com

www.invacare.co.uk



UKRP Invacare UK Operations Limited
Unit 4, Pencoed Technology Park,
Pencoed
Bridgend CF35 5AQ
United Kingdom

 Invacare France Operations SAS
Route de St Roch
F-37230 Fondettes
France

