



**Yes, you can.®**

*Invacare®* **Harrier Range**  

---

**Technical Manual**



## **INTRODUCTION**

This manual is intended for use by trained and approved Service to repair Invacare UK Limited powered wheelchairs. Models covered in this manual are-

Sufficient trouble-shooting information is provided to allow servicing to major component level. Brief description of operation and motor construction are included as background information. However, it is recommended that fault battery charges and motors are returned to Invacare UK Limited for replacement.

## **APPLICATION**

Invacare UK Limited powerchairs enable those who have impaired mobility to lead a full and independent life. They are designed to give safe and reliable service when used under normal use (as instructed in the Owner's Manual).

Careful use, dry storage and regular maintenance will contribute to long and reliable service. Prolonged exposure to, or operation in, harsh weather conditions is not recommended. For further application information, consult the Owner's Manual. There are also several adjustments explained in the Owner's Manual.

## **SAFETY FEATURES**

Invacare UK Limited powerchairs have a high level of features designed to increase safety, including:-

### **Electronic/ dynamic Braking**

The powerchair will brake the motor and charge the battery automatically when decelerating or going downhill. Excessive speed while coasting downhills is therefore prevented and range maximized.

### **Fail-Safe Solenoid Brakes**

Whenever the powerchair is stationary or switched off, the brakes are automatically applied. They operate promptly when the joystick is released and returned to the central position. They will reduce roll-back on ramps and hills to a minimum.

The Penny and Giles controller has additional safety features which monitor the electrical function of the powerchair. Refer to the section in this manual relevant to the controller operation.

## **WARRANTY**

Warranty terms and conditions and recommended procedures are outlined in the Technical Service Manual. Individually applied warranties are included in the User Manual.

## RECOMMENDED SERVICE PROCEDURE

At 6 month period

The following schedule should be used in conjunction with Service Programme Sheet.

- 1 Upholstery
 

Check seat fittings and screw fasteners on back, seat and armpad assemblies and for upholstery wear.
- 2 Control Module
 

On/Off Switch: Press switch down and up several times, making sure the display is illuminated and switch is operating smoothly.

Output Wiring: Check the output socket is located into the control module and is secure. Visually check output cable for damage or incorrect route through framework.

Speed Control: Inspect speed control knob and fixing. Operate speed control making sure output speed of motors is proportional to switch position.

Joystick Control: Visually inspect the joystick control knob, shroud and gaiter. Operate the joystick through all the driving modes.

Mounting Make sure control module is correctly fitted to armrest. Check position of joystick to customer requirements.

Warranty Seal Inspect the control module to see if the manufacturer's seals are intact.
- 3 CASTORS
 

Stem Bearings Check stem bearings for free play and end float. adjust as necessary.

Wheel Bearings Rotate wheel and check bearings for excessive play or noise.

Fork & Axle Check axle bolts and nuts for tightness. Inspect fixing of fork to stem.

Tyres Inspect for damage or foreign objects. Test pressure (pneumatic) as indicated or tyre wall.
- 4 FRAME
 

Foot/Legrests: Check chrome or paint finish. Inspect action of cam lock and fittings. Adjust and tighten footrest position. Check hinging of footplates. Apply WD4O. inspect operation of legrest elevation and calf pad movement.

Anti-Tip Levers: Check fixing and operation. Make sure wheel is in position on stop bar. Apply WD4O.

Armrests: Inspect all fittings and screws. Ensure arm locates into sockets smoothly. Check operation of locking devices. Ensure controller moves freely in slide tube. Check for correct position of stop screw. Check sidepanels for correct position and wear.

Semi-reclining Backs check fittings and forward folding/detachable operation. On powered reclining backs check function and mounting of actuator. Inspect cable and

		hand unit. Check backpost mounting brackets for tightness. Ensure both sides are in same position.
5	BATTERIES	
	Battery Box	Inspect battery box and lid, ensure lid is secure.
	Batteries:	Check battery terminals are tight, clean and apply silicon grease or petroleum jelly.
	Junction Box if fitted (Powered actuators)	Check mounting of junction box to battery box. Inspect wiring harness from junction box to actuator module. Inspect drive plug for function and fit. Check operation of circuit breaker. Check motor socket fittings.
	Control Main Module ( Remote):	Check mounting of controller output module to battery box tray. Check multi-pin connector for fit. Make visual inspection of main module for damage. Inspect warranty seal. Check rear battery tray fittings, ensure secure mountings.
6	MOTORS	
	Mountings:	Inspect motor mountings and fittings. Check function of detach facility and securing of release knob.
	Armature Brakes	Lift rear of chair and mount on blocks. With the drive engaged run motors, return control lever to the central position and Observe operation of brakes. Blow out dust from brake lining.
	Wiring & Connections	Check connections to battery box, make sure the latches are holding the sockets and plugs in position inspect wiring and attachment to frames.
	Brushes	Remove brush cover from sides of motors, observe position of brush in holder. Re-locate in same position. Run motors with drive disengaged and observe brush contact with armature. Blow out carbon deposits.
7	FINAL DRIVE	
	Disengage Mechanism	With wheels raised from the ground engage and disengage final Drive, check for positive re-engagement of drive. Lubricate.
	Drive Shaft:	Revolve wheel assembly with drive disengaged and check for excessive endfloat and bearing wear.
	Wheel Runout	Revolve wheels, checking for excessive 'tow in and excessive side movement of rims. Check for rim damage,
	Tyres	Check tyres for damage and foreign objects. Test pressure (pneumatic) as indicated on the tyre wall.
8	KERB CLIMBER	
	Operation	Check kerb climber on its mounting on the chair, and cam lock operation. Operate forward and return position. Ensure climbing foot is clear of the ground in normal parked position.
	Mounting	Locate the kerb climber to the locating pins, check the locating pin is locking the kerb climber into position. Lubricate with WD4O.

## 9 CHARGER

Mains Plug	Check for any damage to pins or case, inspect cable and entry into charger. Check correct fuse rating ( 5 amp)
Jackplug	Inspect plug and lead for damage. Check entry into charger.
Charging Function	Connect the jackplug into the charging socket, plug the mains plug into the normally used mains socket. Switch mains supply on, and check that the 'mains on light illuminate. The green 'charging light will come on some seconds after this. Because of the length of time involved in the full charging sequence, it is not possible to check the complete charging function.  As the owner whether the charger has been completing its charge programme, through to the red charge complete light illuminating.

## 10 TEST RUN

A short test run should now be carried out to test the driving functions of the chair. If a kerb climber is fitted this also should be tested.

**RECOMMENDED SERVICE PROCEDURE.**

## At 12-18 month period

The following schedule should be used in conjunction with the Service Programme Sheet and Technical Manual.

## 1 Upholstery

Check seat fittings and screw fasteners on back, seat and armpad assemblies and for upholstery wear.

## 2. Control Module

On/Off Switch	Press switch down and up several times, making sure the display is illuminated and switch is operating smoothly.
Output Wiring	Check the output socket is located into the control module and is secure. Visually check output cable for damage or incorrect route through framework.
Speed Control	Inspect speed control knob and fixing. Operate speed control making sure output speed of motors is proportional to switch position.
Joystick Control	Visually inspect the control lever knob. Shroud and gaiter. Operate the joystick through all the driving modes.
Mounting	Make sure module is correctly fitted to armrest. Check position of joystick to customer requirements.
Warranty Seal	Inspect the control module to see if the manufacturer's seals are intact.

## 3. CASTORS

Stem Bearings	Check stem bearings for free play and end float. Replace upper and lower bearing each side.
Wheel Bearings	Rotate wheel and check bearings for excessive play or noise.
Fork & Axle	Check axle bolts and nuts for tightness. Inspect fixing of fork to stem.
Tyres	Inspect for damage or foreign objects. Test pressure (pneumatic) as indicated on tyre wall. Replace is excessive wear.

## 4. FRAME

Foot/Legrests.	Check chrome or paint finish. Inspect action of cam lock and fittings. Adjust and tighten footrest position. Check hinging of footplates. Apply WD4O to moving parts. Inspect operation of legrest elevation and calf and movement.
Anti-Tip Levers	Check fixings and operation. Make sure wheel is in position. Replace if missing or damaged.
Armests	Inspect all fittings and screws. Ensure arm locates into sockets smoothly. Check operation of locking devices. Ensure controller moves freely in slide tube. Check for correct position of stop screw. Check sidepanels for correct position and wear.
Semi-reclining Backs	Check Fittings and forward folding/detachable operation. On powered reclining backs check function and mounting actuator, inspect cable and hand unit. Check backpost mounting brackets for tightness. Ensure both sides are in same position.
Crossbar: Check Crossbar	Centre fixing is not overtightened. Lubricate at hinge points to sideframe using WD4O.

## 5. BATTERIES.

Batteries:	Check batteries for capacity. Replace if below specification.  Check battery terminals are tight. Apply silicon grease or petroleum jelly to terminals.
Battery Box	Inspect battery box and lid. Ensure lid is secure.
Junction Box if Fitted (Powered actuators)	Check mounting of junction box to battery box. Inspect wiring harness from junction box to actuator module. Check operation of circuit breaker. Check motor socket fittings.
Control Main Module (Remote)	Check Mounting of Controller output module to battery box tray. Check multi-pin connector for fit. Make visual inspection of main module for damage. Inspect warranty seal. Check battery tray fittings, ensure secure mountings. Check programme is correct.

## 6. MOTORS

Mountings	Inspect motor mountings and fittings. Check funtion of detach facility and securing of knob. Lubricate sliding contact.
Armature Brakes	Life rear of chair and mount on blocks. With drive engaged run motors return control lever to the central position and observe operation of brakes. Blow out dust from brake lining.
Wiring & Connections	Check connections to battery box, make sure the latches are holding the sockets and plugs in position. Check for discolouration and burning of contacts (evidence of poor contact replace if burning excessive). Inspect wiring and entry to motor brake up.
Brushes	Remove brush covers from sides of motors, observe position of brush in holder. Re-locate in same position. Run motors with drive disengaged and

observe brush contact with armature. Blow out carbon deposits, replace brushed if less than 8mm in length.

## 7. FINAL DRIVE

### Disengage Mechanism

With wheels raised from the ground engage and disengage final drive, check for positive re-engagement of lever

### Drive Shaft

Revolve wheel assembly with drive disengaged and check for excessive endfloat and bearing wear.

### Wheel Runout

Revolve wheels checking for excessive 'tow in and excessive side movement of rims. Check for rim damage.

### Tyres

Check tyres for damage and foreign objects. Test pressure (pneumatic) as indicated on the tyre wall. Replace if treadless.

**CAUTION:** Split rim wheel.

## 8. KERB CLIMBER

### Operation

Check kerb climber on its mounting on the chair and cam lock operation. Apply WD40. operate forward and return position. Replace rubber feet if excessively worn. Ensure foot is clear of the ground in normal parked position.

### Mounting

Locate the kerb climber to the locating pins, check the locating pins is locking the kerb climber into position.

## 9. CHARGER

### Mains Plug

Check for any damage to pins or case. Inspect cable and entry into charger. Check fuse rating fitted to plug (5amp). Check fuse rating at rear of charger.

### Charger Plug

Inspect plug and lead for damage. Check entry into charger. Replace if loose in socket. (check for contact discolouration).

### Charging Function

Connect the charger plug into the charging socket, plug the mains plug into the normally used mains socket. Switch mains supply on and check that the mains on light illuminates. The green charging light will come on some seconds after this. Because of the length of time involved in the full charging sequence, it is not possible to check the complete charging function.

Ask the owner whether the charger has been completing its charge programme, through to the red 'charge complete' light illuminating.

## 10. TEST RUN

A short test run should now be carried out to test the driving functions of the chair. If a kerb climber is fitted this also should be tested.

## **SIDE FRAME REPLACEMENT**

- 1 Dismantle the chair down to the chassis. Remove backrest, seat, battery box assemblies, armrests and motor/ drive wheel assemblies.
- 2 Remove castor wheel assemblies – release castor top nut and withdraw castor fork assemblies from bearings.
- 3 Remove backrests mounting brackets.
- 4 Release and remove nuts and bolts at points (a), (b) and (c). Remove cross-brace assemblies. Follow the instructions for dis-assembly as previously described in guidelines for cross-brace replacement.
- 5 Re-assemble as reverse procedure, ensure all replacement components are securely tightened, (paying particular attention to the backrest mounting position and security).

NB: There may be variations in the colour shade due to the characteristics of the lacquered paint finish

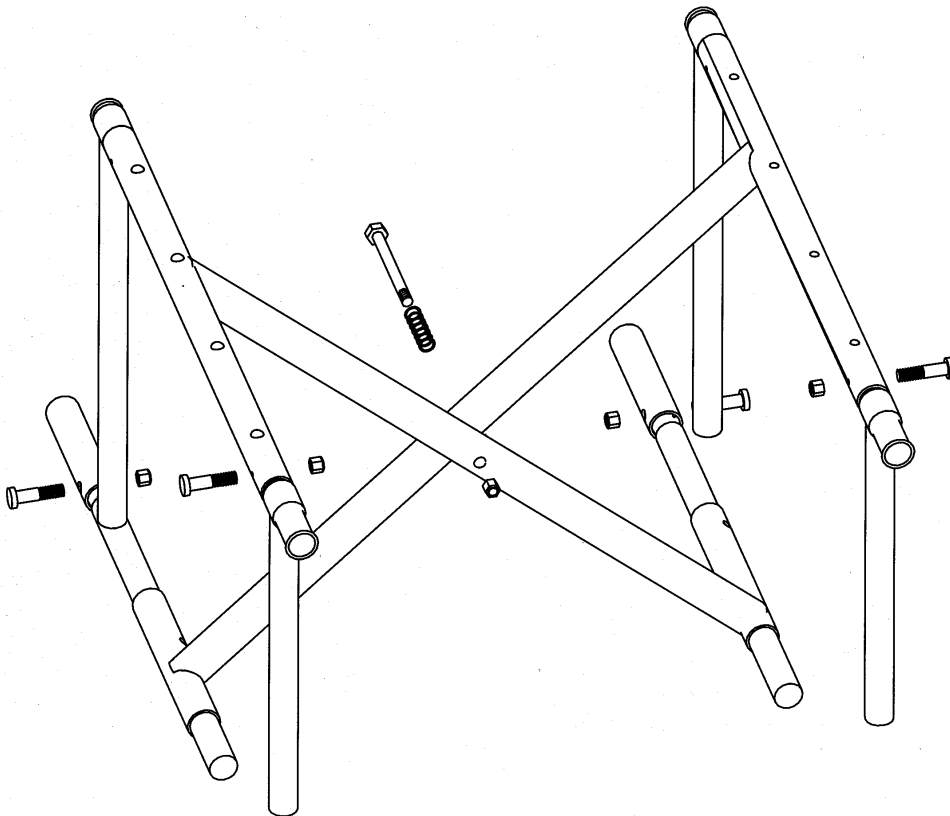

**CROSS-BRACE ASSEMBLIES - REPLACEMENT**

**NB: RIGHT AND LEFT SIDE IS DETERMINED BY BEING SEATED IN THE CHAIR. THE RIGHT HAND CROSS-BRACE IS THE ONE, WHICH HAS ITS LOWER, ATTACHED TO THE RIGHT HAND SIDE FRAME.**

- 1 Dismantle the chair down to the chassis - (Refer to Use Manual). Remove – backrest, seat, battery box assemblies, armrests and motor/ drive wheel assemblies.
- 2 Remove the four M.5 x 28 bolts and nuts (a) from lower rail tubes on both sides of the sideframes.
- 3 Remove bottom inner rail tubes (b) – a large round coarse file, wedged into the center of the tube will be required. Twist and pull to remove.
- 4 Remove the four M.5 x 28 bolts and nuts (c) from upper seat rail tubes. Withdraw front (d) and rear (e) inner seat rail tubes.
- 5 Withdraw front (f) and rear (g) front slide post tubes. Check that these tubes slide freely up and down within the slide frame tubes. Replace if these tubes bind in any way. Apply a small amount of WD40 to inner tube.
- 6 Remove cross-brace assembly from the chair – dismantle center bolt, spring and nut (h)

Re-assembly is the reverse procedure, taking care to ensure the nut on the center bolt has two clear threads only showing through the nut. Do not fully tighten as the articulation between the cross-bars is important.

---

## SEAT DEPTH/ BACK ANGLE ADJUSTMENT

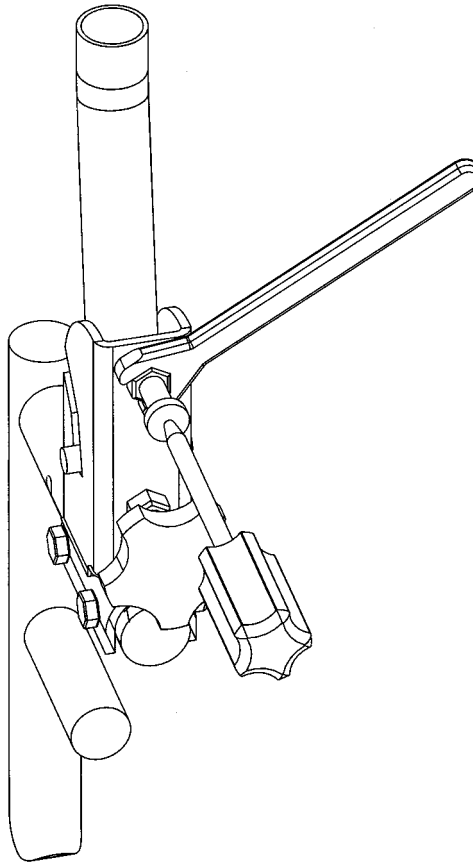

### SEAT DEPTH ADJUSTMENT (Can be adjusted by 35mm)

Tools required: 2 x 10 mm spanners

- 1 Unscrew and remove bolts and nuts (a) from the backrest mounting brackets.
- 2 Move the backrest to the extended position. Replace the bolts and nuts into the mounting bracket and sideframe and tighten securely.

### BACKREST ANGLE ADJUSTMENT (Can be adjusted from 90deg. Rearwards through 12deg).

Tools required: 1 x 13mm spanner, medium cross head screw driver.

- 1 Release lock nut (b) located on the cross-headed screw.
- 2 Screw the handwheel (c) partially out under normal hand pressure.
- 3 Screw the cross-headed screw in or out to give the required back angle position. Adjust the position of the handwheel as necessary.
- 4 Position the locknut up to the mounting bracket and fully tighten.
- 5 Re-adjust the handwheel (c) fully, ensuring the backrest assembly is secure.

**NOTE:** Each backrest tube must be positioned in the same plane as each other or the backrest will be twisted.

## BACKREST MOUNTING

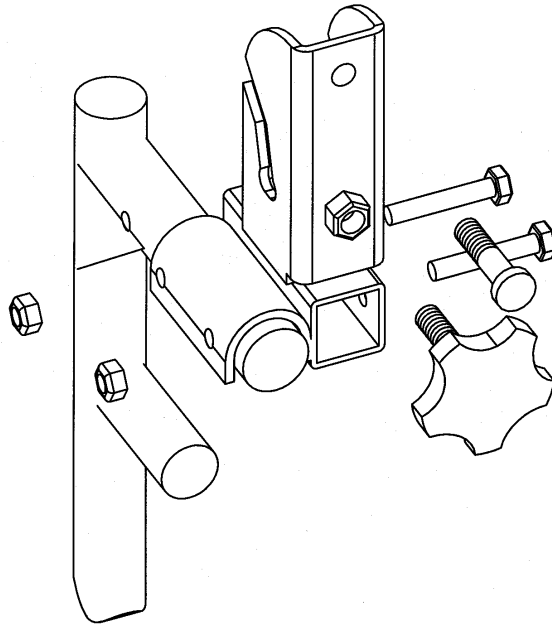

### BACKREST MOUNTING BRACKET – REPLACEMENT

- 1 Remove the two M.6 x 35 hex head screws and nuts (c) holding bracket to side frame.
- 2 Remove hand wheel (b) using grips to overcome resistance of retaining pips on the thread, which prevents accidental removal.
- 3 Remove M.8 x 30 pan head screw by slackening lock nut and unscrewing from bracket.
- 4 When fitting, the hand wheel (b) should be screwed into the lower of the mounting bracket and three indentations punched into the end two threads to prevent complete withdrawal and possible loss.
- 5 The two M.6 x 35 bolts (c) must be securely tightened when the mounting bracket is assembled to the side frame.

**NOTE:** It is advisable to fit the complete backrest assembly and check alignment/ clearances prior to final tightening.

---

## BACKREST SUPPORT ASSEMBLY

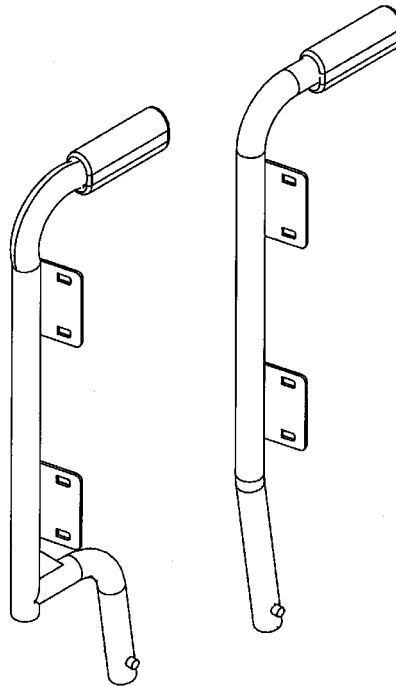

### SINGLE AND COMBINED BACKREST SUPPORT (STANDARD AND SWAN-NECK VARIATIONS)

The backrest support can be folded down or detached for improved portability. (Refer to the User Manual for this procedure).

### REPLACEMENT

Replacement backrest assemblies are supplied complete with handgrips and locating components. If the handgrips require replacement, cut through with a sharp blade and peel off. The replacement handgrip must be secured with a recommended adhesive (e.g. hot glue, contact Invacare for guidance).

**If the locating components require replacement, follow this procedure:-**

Loosen grub screw (1d) and tap out locating Cross pin, the reinforcing plug can now be removed. Replacement/ re-assembly is the reverse procedure. Insert reinforcing plug (1b) should be fitted with Loctite Screwlock and securely tightened into the cross pin.

## ARMREST SUPPORT - HEIGHT AND WIDTH ADJUSTMENT

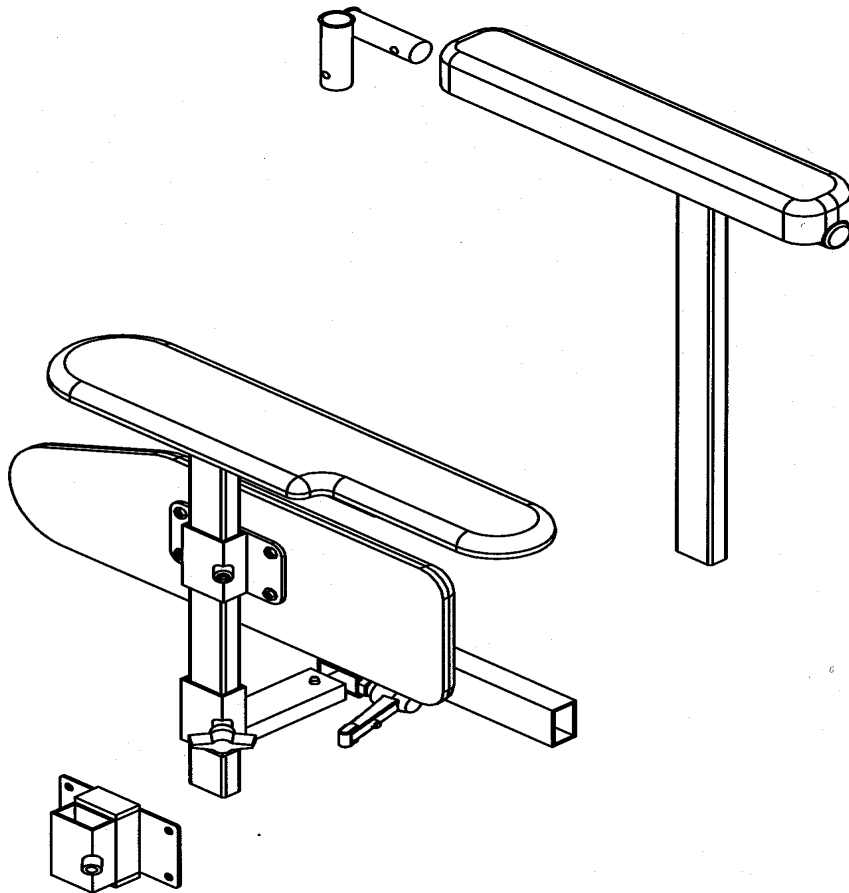

### HEIGHT ADJUSTMENT

The armrest can be pre-set for height. Select suitable position and fix the self tapping screw (f) in one of the holes in the vertical support tube. Do this for both sides as required.

The upholstered side panel can also be set to the required height. Loosen the slotted grub screw (d) located in the mounting bracket, re-tighten at selected position.

Re-locate complete assembly onto the chair and check with occupant for correct position and comfort.

### TRANSVERSE WIDTH ADJUSTMENT

With armrest assembly in place, release locking lever (g) and slide the transverse mounting bracket in or out to achieve the desired seat width.

To remove transverse mounting bracket, depress button lock (f) and withdraw the unit sideways.

Depending on the width of the chair it may be necessary to carry out this operation to remove the front battery box assembly.

**NOTE:** Ensure the spring button lock (f) located on the inside of the horizontal mounting tube of the side frame and locked in position facing upwards.

Item 3 reduces the width between the side panels by 20mm each side. This will reduce the overall seat width by approximately 40mm.

## ARMREST SUPPORT ASSEMBLY

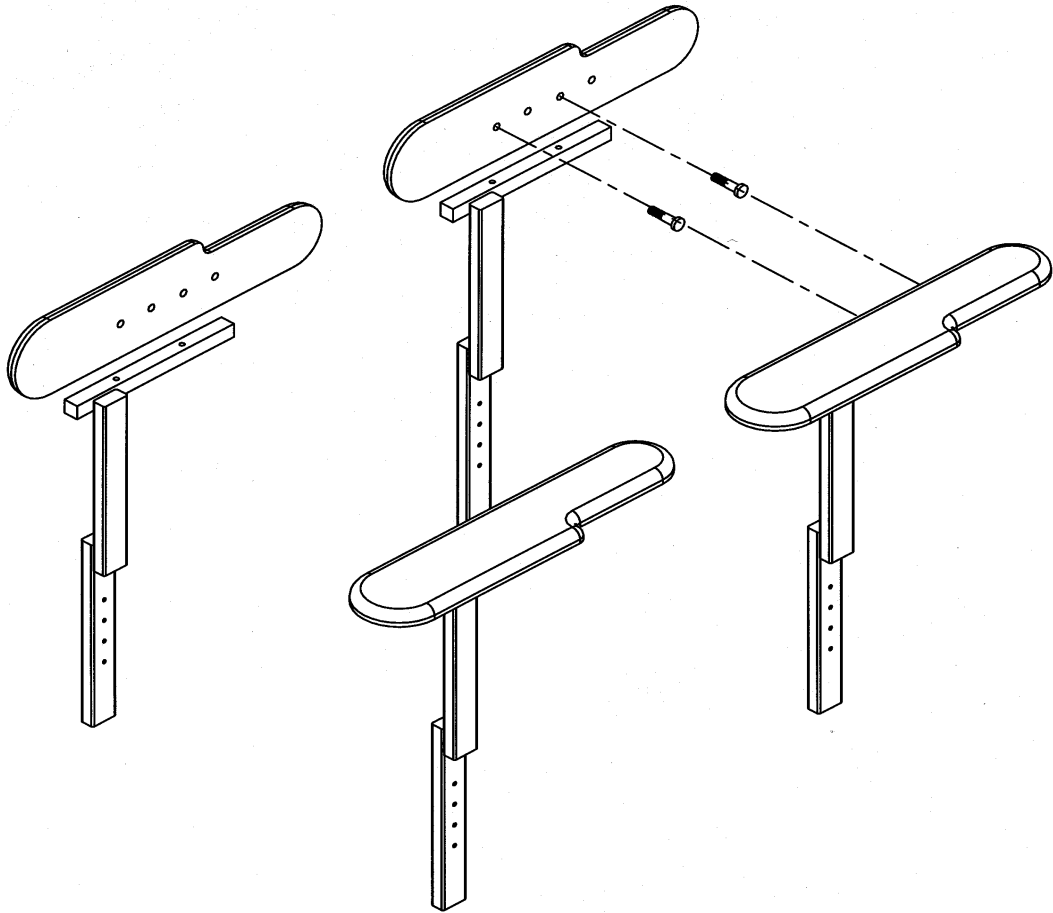

### ARMREST SUPPORT ASSEMBLY REPLACEMENT

- 1 Remove armrest from chair (Ref. To User Manual)
- 2 Remove panel mounting bracket (1b or 2) by releasing M.8 grub screw (1c).
- 3 End plugs (1d & 1e) may be prised from the tube using a thin blade etc.

Re-assembly is the reverse of the above procedure. If suitable, gently tap end bungs (1d & 1e) back into position.

### UPHOLSTERED ARMPAD REPLACEMENT – ADJUSTMENT

The armrest pad can be located on the armrest support assembly to achieve the most suitable position for the occupant.

The armrest can also be reversed and crossed over to account for the variations and reductions in width.

To remove, loosen the two M.5 x 35 bolts (f) fixing the armrest pad to the support tube. Tighten to secure. Do not overtighten as this will result in the T-nut insert becoming ineffective.

When the double panel mounting bracket (2) is fitted to reduce the overall seat width by 40mm, crossover the armpads from side to side.

## UPHOLSTERED HEADREST ASSEMBLY

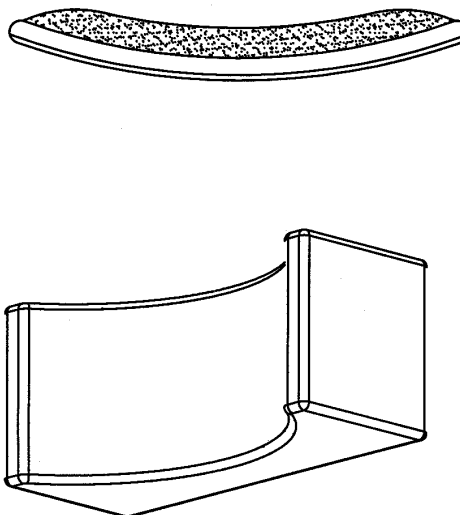
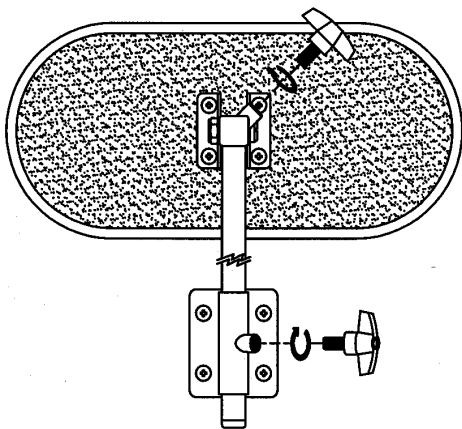

### FITTING

Fit the headrest mounting bracket (a) to the upholstered backrest. Locate the four T- nut inserts (b) which are already fitted into the top of the internal plywood former. Refer to the above approximate measurements.

Carefully pierce the vinyl, pushing into the T-nut insert, taking care not to pierce right through the foam into the front of the backrest.

Attach the mounting bracket (a) using four M.5 x 10 pan-headed screws. Ensure that the screws do not protrude through the upholstery and cause discomfort. Over tightening of these screws will result in damage to the T-nut inserts and their purpose becomes ineffective.

Slot mounting support tube into the bracket, adjust to required height and tighten wing screw (b).

Adjust fore and aft position by releasing the horizontal mounting tube using wing screw (c) and re-tightening to the desired position.

Items 2 and 3 are curved variations of the upholstered pad assembly.

Refer to recommended instructions on care and maintenance of vinyl materials of the upholstery is showing signs of damage or premature wear.

## VINYL UPHOLSTERY

### CARE AND MAINTENANCE OF VINYL UPHOLSTERY

**This is the approved recommended care supplied by the material manufacturers.**

To maintain the appearance of PVC coated fabrics, they should be cleaned regularly to remove fatty substances in soiling which may reduce their serviceable life. A soft cloth and warm soapy water should be used to clean the surface of the material. Mild soap flakes are recommended and residual soap removed using cold water. The surface should then be dried with clean soft cloth. If the dirt is ingrained, the surface can be lightly scrubbed with soft brush.

Solvent cleaners, wax polishes, strong detergents and patent chemical cleaners should not be used. The use of these substances is likely to be harmful to PVC coated fabrics and repeated use can result in the removal of the plasticiser from the PVC coating which will result in hardening and subsequent cracking of the material's surface. The result of these conditions cannot be covered under the standard terms and conditions of the warranty agreement.

PVC coated fabrics are resistant to most mild acids, alkalis and household stains. Some substances such as ball-point pen ink, lipstick, newsprint and food colourings may be absorbed by the vinyl and cause permanent staining. This can be minimized by immediate cleaning with a damp, soapy cloth or sponge.

Ultra-violet light can also reduce the life of the upholstery coating material, this is normal ageing process and cannot be covered under the standard terms and conditions of the warranty agreement. Necessary precautions should be taken to guard against periods of long term exposure to ultra-violet light. During scheduled service and maintenance checks, inspect the condition of the upholstery edging to ensure that due to impact damage etc. no sharp edges are protruding which may cause injury.



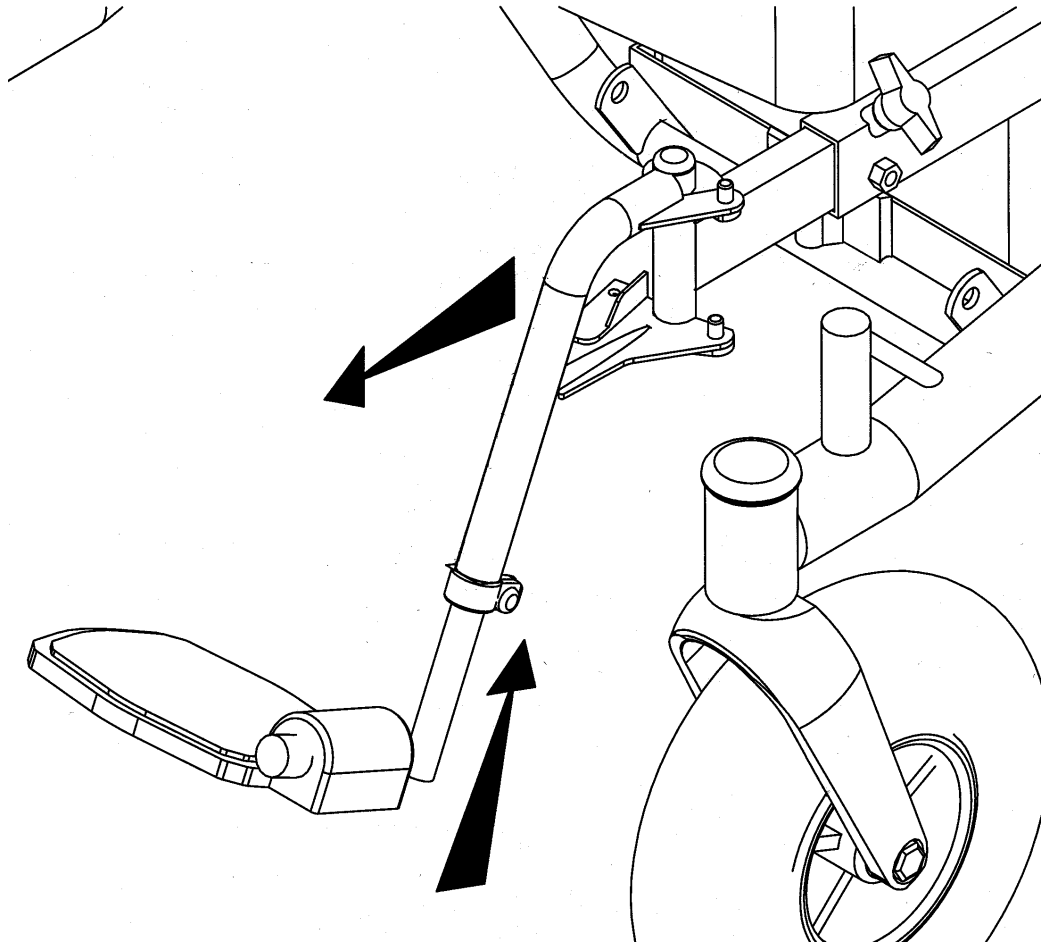

**FOOTREST - HANGER ASSEMBLY****HANGER TUBE ASSEMBLY - RELEASE LEVER REPLACEMENT**

Release lever (i) may be removed by dismantling the M.5 screw (d) and nut (h). take care not to lose the spacers (e & g). Note their positions, i.e. the stepped one (e) on top. The torsion spring (f) is handed item,

Re-assembly is the reverse procedure of above, taking care to fit the correct handed torsion spring (f) and locate it correctly.

Tighten the M.5 self-lock nut (h) sufficiently to allow free movement of the release assembly.

Fit the assembly to the chair, ensuring the footrest assembly locks into place. Final adjustment can be achieved by gently tapping the locating hinge(c) up or down. Test until the assembly locks correctly.

Check that correct locking is not restricted by the tube end bung (j), tap right home.

## FOOTREST - EXTENSION ASSEMBLY

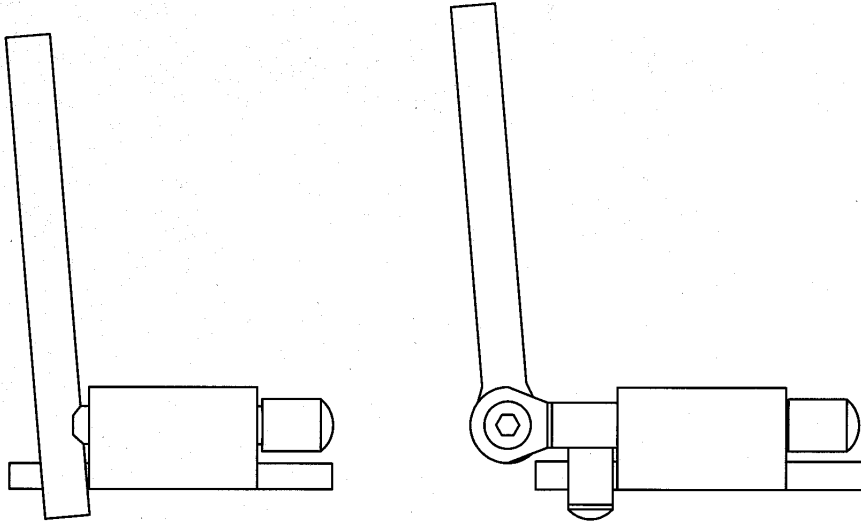

### FOOTREST EXTENSION ADJUSTMENT

- 1 Loosen clamp bolt and nut (a & b) on the hanger tube assembly, using a 13mm spanner.

Using a twisting action, adjust the footrest up or down to the required length.

Ensure the bolt located into the notch and domed head is on the inside of the chair.

Tighten the clamp bolt sufficiently so that the footplate will not swivel when weight is applied.

**CAUTION:** The lowest position of the footplate must be at least 6cm from the ground for clearance.

### FOOTPLATE REPLACEMENT

The footplate (d) can be removed from the extension tube (c) by removing the end bungs or bumper rollers, collars and the self tapping screw which secure these components. The footplate can now be twisted and pulled off the tube. NOTE the leaf spring and its positioning.

Re-assembly of the footplate to the extension tube will be much easier if a mild steel tapered service tool is available. This is placed in the end of the short length of the extension tube (c) and the footplate complete with the correctly positioned leaf spring, is fed down over the service tool.

## CASTOR FORK ASSEMBLIES

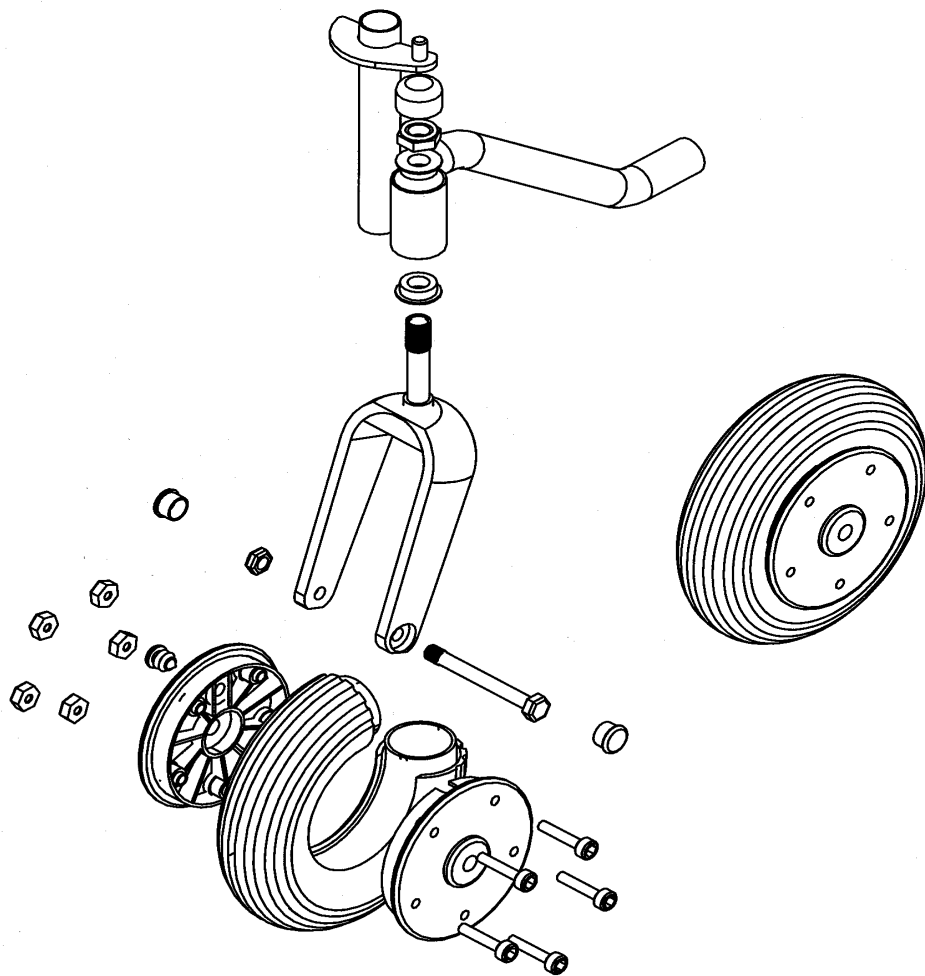

### SERVICE – REPLACEMENT

- 1 Raise front of wheelchair off the ground, rock assembly to and from to check for free play of top and bottom stem bearings, if slight, adjust locknut (a) sufficiently to take up free play, spin assembly, check that it rotates freely. Remove dirt and grit etc.  
Follow this procedure:-
- 2 Remove nut cap (b). Hold fork (c) and unscrew the self locking nut (a), retain. Withdraw assembly downwards from the bearings, inspect the fork stem of excessive wear and tightness of fork to stem locking nut (d). Replace if either is evident.
- 3 Remove bearings (h) from housing with suitable tool, fit replacement bearings by pressing in or gently taping into place. Take care not to damage bearings casing.
- 4 Replace fork assembly and fully tighten locking nut (a) to seat top and bottom bearings. Adjust nut (a) to allow fork assembly to swivel smoothly without free play.
- 5 Wheel may be removed from fork by prising off plastic caps (e) and unscrewing nut from axle bolt, withdraw bolt taking care to retain any washers and re-fitting as per removal.
- 6 Pneumatic tyres, tubes and puncture proof infills can be replaced by dismantling the five nuts and bolts (g) and separating the two halves of the hub\*.

**\*NOTE:** PNEUMATIC TYRES MUST BE DEFLATED BEFORE FOLLOWING THIS PROCEDURE.

## DRIVE WHEEL REMOVAL

### PROCEDURE FOR FLEXEL PUNCTURE PROOF REPLACEMENT AND PUNCTURE REPAIR

**CAUTION:** WHEEL IS SPLIT RIM – FOLLOW CAREFULLY RECOMMENDED GUIDELINES

Pull off the plastic wheel cover, release the five M8 x 20 inner bolts, shown as (a) in the diagram.

**It will be necessary to split the wheel rims to replace the FLEXEL puncture proof infill.**

It is of the utmost importance that the five outer bolts and nuts shown as (b) in the diagram as NOT released until the tyre is fully deflated,

Repair or replace pneumatic tyres/ inner tubes by levering the tyre off the wheel rim as on bicycles etc.

Inflate pneumatic tyres to recommended pressure:- Min. 35psi. – Max. 40psi. (Min. 238 kpa – Max 272 kpa.)

If the tyre is being inflated with the wheel on the chair, ensure the wheels are off the ground during inflation.

Inflate gradually to ensure even fit around the wheelrim.

Under inflated tyres will have an effect on the overall range and performance of the vehicle.

## 1.0 Introduction

The relevant contents of this chapter should be included in the wheelchair operating guide. Further copies are available from Penny & Giles in both written or disk ( Word for Windows) format. Copies should not be made without the express permission of Penny & Giles.

The operation of the Pilot+ wheelchair control system is simple and easy to understand. The control system incorporates state of the art electronics, the result of many year of research to provide you with ease of use and a very high level of safety. In common with other electronic equipment, correct handling and operation of the until will ensure maximum reliability.

## 2.0 General

A Pilot + control systems comprises of two or three modules. Joystick Module, Power Module and Actuator and Lighting Module (ALM). The ALM is only required if the wheelchair if fitted with lights or seat adjustment actuators. The diagram below shows the modules and the connections between them.

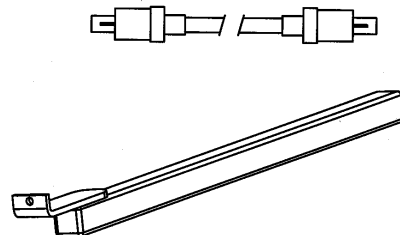
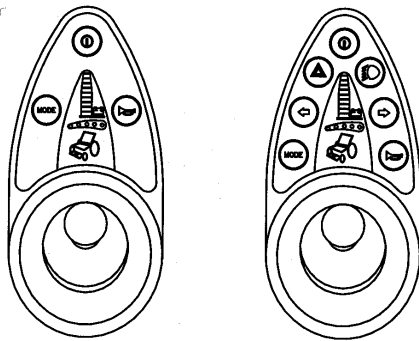
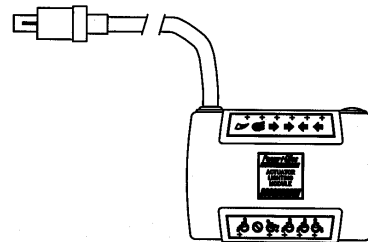
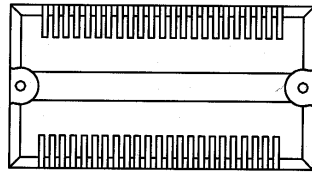

## 2.1 Handling

Avoid knocking your control system and especially the joystick. Be careful not to strike obstacle with the control system or joystick when you drive. Never drop the control system.

When transporting your wheelchair, make sure that the control system is well protected. Avoid damage to cables.

## 2.2. Operating Conditions.

Your control system uses industrial grade components throughout ensuring reliable operation in a wide range of conditions. However, you will improve the reliability of the control system if you keep exposure to extreme conditions to a minimum.

Do not expose your control system or its components to damp for prolonged periods, if the control system becomes contaminated with food or drink clean it off as soon as possible.

## 2.3. Cleaning

Clean the control system and the joystick with a cloth dampened with diluted detergent. Be careful when cleaning the joystick.

Never use abrasive or spirit based cleaners.

## 3.0 Controls

The Pilot +system has two versions of Joystick Module. With and without lighting control- refer to page 1:4 see which type you fitted to your wheelchair. Most of the controls are common to both modules, however, the lighting, turn indicator and hazard warning controls are only included on the Joystick Module with lighting control. Each of the controls is explained below:

### 3.1 On/Off Switch and Battery Gauge

The on/off switch applies power to the control system electronics, which in turn supply power to the wheelchair's motors. Do not use the on/off power switch to stop the wheelchair unless there is an emergency. (if you do, you may shorten the life of the wheelchair drive components).

The battery gauge shows you that the wheelchair is switched on. It also indicates the operating status of the wheelchair. Details are given in section 8.0.

When the wheelchair is switched on, each of the LEDs on the joystick Module will briefly illuminate, if any of the LEDs is not illuminate, contact your service agent.

### 3.2. Security Key

The security key can be used to lock the wheelchair to prevent unauthorized use. To lock the wheelchair it must be switched on, the key should then be inserted into and withdrawn from the battery charging socket, the wheelchair will not be locked.

To unlock the wheelchair, firstly, switch it on, the maximum speed indicator will ripple up and down but driving will not be possible. the key should now be inserted into and withdrawn from the battery charging socket, the wheelchair can no be driven.

## JOYSTICK MODULE DETAILS

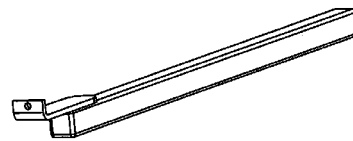
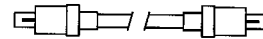
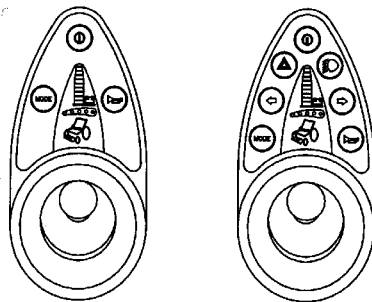
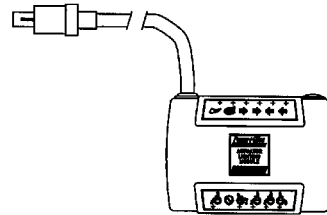
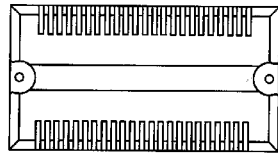

Joystick Module without Lighting

Joystick Module with Lighting

### Controls

ON/OFF SWITCH

BATTERY GAUGE

MAXIMUM SPEED INDICATOR

MODE SWITCH

HORN SWITCH

LIGHTS SWITCH AND LED

LEFT TURN INDICATOR SWITCH AND LED

RIGHT TURN INDICATOR SWITCH AND LED

HAZARD WARNIG SWITCH AND LED



### 3.3. Joystick

The joystick controls the speed and direction of the wheelchair. The further you push the joystick from the center position the faster the wheelchair will move. When you release the joystick the brakes are automatically applied.

### 3.4. Maximum Speed indicator

This is a gauge that shows the maximum speed setting of the wheelchair. There are five speed settings step 1 is the lowest speed and step 5 is the highest speed. For details of how change the maximum speed setting, see section 3.5.

### 3.5. Mode Switch

The mode switch is used to make maximum speed changes and to change between wheelchair operation modes.

If the mode switch is operated whilst you are driving the maximum speed setting will be increased by one step. Each successive operation of the mode switch will increase the setting, when the setting is at 5 the next mode switch operation will put the setting to 1. The diagram below explains this action.

If the mode switch is operated when the joystick is centered, the control system operation mode will be change. There are three modes, drive, speed adjustment and actuator adjustment. The diagram below explains this action.

### 3.5.1 Speed adjustment mode

when the control system is in this mode the maximum speed indicator will flash. The maximum speed can be adjusted by left or right movements of the joystick. Left will decrease the speed setting, right will increase it. Forward or reverse movements of the joystick will take you back into drive mode.

Operating the mode switch will put the control system back into drive mode or, if seat adjustment actuators are fitted, actuator adjustment mode.

### 3.5.2 Actuator Adjustment Mode

When the control system is in this mode the actuator indicator will be illuminated. The section of the wheelchair symbol that is illuminated shows the actuator that is selected for adjustment, to change the selected actuator move the joystick left or right. To make an actuator adjustment move the joystick forwards or backwards.

Operating the mode switch will put the control system back into drive mode

### 3.6. Horn Switch

The horn will sound whilst this switch is depressed.

### 3.7. Lights Switch and LED

To turn on the wheelchair's lights operate this switch, the associated LED will illuminate.

### 3.8. Right Turn indicator switch and LED

To turn on the wheelchair's right turn indicator operate this switch, the associated LED will flash at the same rate. If the LED flashes rapidly, one of the left turn indicator bulbs is defective, contact your service agent.

### 3.9. Right Turn Indicator switch and LED

To turn on the wheelchair's right turn indicator operate this switch, the associated LED will flash at the same rate. If the LED flashes rapidly, one the right turn indicator bulbs is defective, contact your service agent.

### 3.10 Hazard Warning Switch and LED

To turn on the wheelchair's hazard warning lamps operate this switch, the associated LED will flash at the same rate. The left and right turn indicator LEDs will also flash.

## 4.0 Getting Ready to Drive

Operate the on/off switch. The battery gauge will blink then turn on after a second.

Check that the maximum speed control is set to a level which suits you.

Push the joystick to control the speed and direction of the wheelchair.

Please note that if you push the joystick before or just after you switch the control system on, the battery gauge will ripple up and down and the wheelchair will be allowed to move. You must release the joystick to resume normal operation. If you do not release the joystick within five seconds the wheelchair will not be able to move, even if you release the joystick and push it again. The battery gauge will then flash rapidly. You can reset this condition by switching the control system off and on again.

If you do not push the joystick as you switch the wheelchair on and the battery gauge flashes rapidly, then there may be a fault. Refer to section 8.4. for details.

## 5.0 Tips for Using Control System

### 5.1. Driving – General

Make sure that the control system is mounted securely and the joystick position is correct. The hand or limb you use to operate the joystick should be supported, for example by the wheelchair arm pad. Do not use the joystick as the sole support for your hand or limb – wheelchair movements and bumps could upset your control.

## 5.2. Driving Technique

The control system interprets your joystick movements and produces appropriate movements of Your wheelchair. You will need very little concentration to control the wheelchair, which is especially useful if you are inexperienced. One popular technique is to simply point the joystick in the direction you want to go. The wheelchair will “home-in” on the direction you push the joystick.

The further you push the joystick away from the rest position, the faster the wheelchair will go.

The intelligent speed control system minimizes the effects of slopes and different types of terrain.

## 6.0 Precautions for Use

Note: In the event of the wheelchair moving in an unexpected way release the joystick. This action will stop the wheelchair under any circumstances.

### 6.1 Hazards

Do not drive the wheel chair:-

- i) Beyond restrictions indicated in your wheelchair user manual, for example maximum inclines, curb, height etc.
- ii) In places or on surfaces where a loss of wheel grip could be hazardous, for example on wet grassy slopes.
- iii) If you know that the control system or other crucial components require repair.

**WARNING:** Although the Pilot+ control system is designed to be extremely reliable and each unit is rigorously tested during manufacture, the possibility of a system malfunction always exists (however small the probability). Under some condition of system malfunction the control system must (for safety reasons) stop the chair instantaneously. If there is any possibility of the user falling out of the chair as a result of a sudden braking action, it is imperative that a restraining device such as seat belt is supplied with the wheelchair and that is in use at all times when the wheelchair is in motion. Penny & Giles accept to no liability for losses of any kind arising from the unexpected stopping the wheelchair, or arising from the improper use of the wheelchair or control system.

## 7.0 Safety Checks

The electronic circuits in your control system have been designed to be extremely safe and reliable. The on-board microcomputer carries out safety checks at up 100 times per second. To supplement this safety monitoring you should carry out of the following periodic checks.

If the control system fails any these checks, do not use the wheelchair and contact your service agent.

### 7.1 Daily Checks.

**Joystick:** With the control system switched off, check that the joystick is not bent or damaged and that it returns to the center when you push and release it. If there is a problem do not continue with the safety check and contact your service agent.

## 7.2 Weekly Checks

Solenoid (Parking) brake: This test should be carried out on a level floor with a least one meter clear space around the wheelchair.

- i) Switch on the control system.
- ii) Check the battery gauge remains on, or flashed slowly, after one second.
- iii) Push the joystick slowly forwards until you hear the parking brake operate. The chair may start to move.
- iv) Immediately release the joystick. You must be able to hear each parking brake operate within a few seconds.
- v) Repeat the test a further three times, pushing the joystick slowly backwards, left and right.

**Connectors:** Make sure that all connectors are securely mated.

**Cables:** Check the condition of all cables and connectors for damage.

**Joystick gaiter:** Check the thin rubber gaiter or boot, around the base of the joystick shaft, for damage or splitting. Check visually only, do not handle the gaiter.

**Mounting:** Make sure that all the components of the control system are securely mounted. Do not over tighten any securing screws.

## 7.3. Servicing

To ensure continued satisfactory service, we suggest you have your wheelchair and control system inspected by your service agent after a period of 1 year from commencement of service. Contact your service agent for details when the inspection is due.

## 8.0 Status indication

The battery gauge will indicate the status of the control system.

Please note that a number of supposedly faulty control systems returned to us are subsequently found to operate correctly. This indicates that many faults are due to the wheelchair problems rather than the control system.

### 8.1 Battery Gauge Steady

This indicates that all is well.

### 8.2 Battery Gauge flashes slowly

The control system is functioning correctly, but you should charge the battery as soon as possible.

### 8.3. Battery Gauge Blinks Once Every 2.5. Seconds.

The control system has "gone to sleep" because the joystick has not been operated for a period of time. This time period depends on the programming of the system. To re-start, switch the system off and on again.

### 8.4. Battery Gauge Flashes Rapidly (even with the joystick released)

The control system safety circuits have operated and the control system has been prevented from moving the wheelchair.

This indicates that there is no fault. Please follow this procedure:

- i) Switch off the control system
- ii) Make sure that all connectors on the wheelchair and the control system are mated securely.
- iii) Check the condition of the battery.
- iv) If you can't find the problem, try using the self- help guide given in section 8.5.
- v) Switch on the control system again and try to drive the wheelchair. If the safety circuits operate again, switch off and do not try to use the wheelchair. Contact your service agent.

### 8.5. Self- Help Guide

If a fault occurs, you can find out what has happened by counting the number of bars on the battery gauge that are flashing.

Here is a list of self-help actions. Try to use this list before you contact your service agent. Go to the number in the list which matches the number of flashing bars and follow the instructions.

**1 bar:** The battery needs charging or there is a bad connection to the battery. Check the connections to the battery and check the Power Module battery connector, this is the 2 pole connector situated between the two motor connectors. If the connections are good, try charging the battery.

**2 bar:** The left hand motor has a bad connection. Make sure that the motor is connected properly and the Power Module connector M1 is secure.

**3 bar:** The left hand motor has a short circuit to a battery connection. Contact your service agent.

**4 bar:** The right hand motor has a bad connection. Make sure that the motor is connected properly and the Power Module connector M2 is secure.

**5 bar:** The right hand motor has a short circuit to a battery connection. Contact your service agent.

**6 bar:** The battery charger is preventing the control system from driving the wheelchair. Disconnect the charger from the wheelchair.

**7 bar:** A joystick Module fault is indicated. Make sure that the joystick is in the rest position before switching on the control system.

**8 bar:** A Power Module fault is indicated. Make sure that all Power Module connections are secure.

**9 bar:** The parking brakes have a bad connection. Check the parking brake and motor connections. Make sure the control connections are secure.

**10 bar:** An excessive voltage has been applied to the control system. This is usually caused by a poor battery connection. Check the battery and Power Module connections.

If the problem persists after you made the checks described above contact your service agent.

## 8.6. Slow or sluggish movement

If the wheelchair does not travel at full speed or does not respond quickly enough, and the battery condition is good, check the maximum speed setting. If adjusting the speed setting does not remedy the problem then there may be non-hazardous fault.

## 9.0 Battery Gauge

The battery gauge is included to let you know how much charge is left in your batteries. The best way for you to use the gauge is to learn how it behaves as you drive the wheelchair. Like the fuel gauge in a car, it is not completely accurate, but it will help you avoid running out of "fuel"

The battery gauge works in the following way:

When you switch on the control system, the battery gauge shows an estimate of the remaining battery charge.

The battery gauge gives you a more accurate reading about a minute after you start driving the wheelchair.

Note: When you replace worn out batteries, fit the type recommended by the wheelchair manufacturer. If you use another type the battery gauge may be inaccurate.

The amount of charge in your batteries depends on a number of factors, including the way you use your wheelchair, the temperature of the batteries, their age and the way they are made. These factors will affect the distance you can travel in your wheelchair. All wheelchair batteries will gradually their capacity as they age.

The most important factor that reduces the life of your batteries is the amount of charge you take from the batteries before you recharge them. Battery life is also reduced by the number of times you charge and discharge the batteries.

To make battery gauge reading seems to fall more quickly than usual. You batteries may be worn out.

### 9.1. How to Read a TruCharge Battery Gauge.

If the battery gauge shows red, yellow and green, the batteries are charged.

If the battery gauges show just red and yellow, then you should charge the batteries as soon as you can.

If the battery gauge shows just either steady or flashing slowly, then you should charge the batteries immediately.

## 10.0 Battery Charging

To charge the wheelchair batteries connect the charger plug into the battery charging socket on the Joystick Module. You will not be able to drive wheelchair when the charger is connected.

**WARNING: Use only the battery charger that has been supplied with your wheelchair. The use of incorrect chargers could damage the batteries, wheelchair or charge itself.**

## 11.0 Programming

If you find that you cannot find a maximum speed control setting that suits you, the control system can be programmed to meet your needs.

The PP1 is a small hand-held unit, which can be plugged into your control system to alter the program. A PP1 may be included with wheelchair. If a PP1 is not included, your wheelchair distributor or service agent or wheelchair manufacture will be able to program your control system for you.

If you have a PP1, read the PP1 user guide before you use it.

If you re-program your control system. Make sure that you observe any restrictions given in your wheelchair user manual. Note any changes you make for future reference.

**WARNING: Programming should only be conducted by healthcare professionals with in depth knowledge of Penny & Giles electronic systems. Incorrect programming could result in an unsafe set-up of a wheelchair for user. Penny & Giles accept no liability for losses of any kind if the programming of the control system is from factory pre-set values.**

## **12.0 Joystick Knobs**

The knob fitted to your joystick is suitable for most applications. If you would prefer another type, there is a range of alternative available, Please contact your wheelchair distributor or manufacturer for advice. Do not replace the joystick knob with any unauthorized item it may cause hazardous operation.

## **13.0 Servicing**

All repairs and servicing must be carried out by authorized service personnel. Opening or making any unauthorized adjustments or modifications to the control system or its components will invalidate any warranty and may result is hazards to yourself or other people, and is strictly forbidden.

**WARNING: Penny and Giles accept no liability for losses of any kind arising from unauthorized opening, adjustment or modifications to the Pilot+ control system.**



**PILOT + DIGITAL POWERCHAIR CONTROL SYSTEM**

**CHAPTER PROGRAMMING**

## 1.0 Programming for Wheelchair Control System

The main advantage of using programmable control system is that they can be easily tailored to the specific needs and capabilities of a particular wheelchair user while taking into account the safe performance characteristics of the wheelchair being used. This means that wheelchairs fitted with a Penny & Giles Pilot + control system can be readily programmed to be safe under normal driving conditions and also feel secure and comfortable to the user.

The programmable control system achieves this great flexibility by referring to a set of internal parameters, which govern factors such as the wheelchair's speed, acceleration and braking. These parameters can be changed over a wide span to suit different wheelchairs and users, using a simple, hand-held programmer. Minimum and maximum limits can be applied to these parameters, thereby ensuring the wheelchair can only be programmed within a certain operating envelope. These limits can only be altered with the agreement of the wheelchair manufacturer and Penny & Giles.

All programmable values are stored within the Power Module, therefore, if you change a Joystick Module of ALM there is no need to re-program the system.

### 1.1 Important Note

It is possible to set up a control system so that it is unsuitable for some users and possibly even some wheelchairs. Take care when programming a control system and if you need advice on programming or selecting values, please do not hesitate to contact Penny & Giles.

**WARNING: Programming should only be conducted by healthcare professionals with in-depth knowledge of Penny & Giles electronic control system. Incorrect programming could result in an unsafe set up of a wheelchair for a user. Penny & Giles accept no liability for losses of any kind if the programming of the control system is altered from pre-set values.**

## 2.0 PPI Programmer

The PP1 is the handheld programmer that Penny & Giles supply for their Pilot + control systems. Primarily intended for the specialized design and test requirements of wheelchair manufacturers and engineers, the PPI takes full advantage of the complete programmability of the Pilot + offering functions not available with less sophisticated control system designs.

The PPI is a menu-driven programmer, which plugs directly into the Pilot+ battery charging socket and is available in two configurations, suited to different applications.

### 2.1 Basic PP1 Programmer (PP1a)

The most basic programmer version – the PP1a is intended for general purpose use. It can set all of the key control system speed, acceleration and braking characteristics, and allows different settings to be tried out while the programmer is still plugged into the control system. A context-sensitive help function is available to guide users through the menus and the PP1 can display error messages from the Pilot + control system, allowing any problems with the wheelchair electrical system to be identified and corrected quickly. In addition, the Pilot + fault log and elapsed time indicator can be read with the PP1a.

### 2.2. Engineering PP1 Programmer (PP1b)

The engineering version, the PP1b, offers all of the PP1a features but also includes a suite of advanced functions for designers, such as matching the control system to the motor impedance, setting maximum drive current and enabling front or rear wheel drive algorithms. Clearly, the PP1b is a very powerful tool for prototype design work. However, users who program parameters incorrectly do run the risk of damaging control systems or motors, so it should only be used by experts in wheelchair electrical systems.

## 2.3. PP1 Specifications

FUNCTIONS	NOTES	PP1a	
Acceleration	Vary from 0 (or factory set min) to 100 (or factory set max)	Unit Steps	Unit Steps
Deceleration	Vary from 0 (or factory set min) to 100 (or factory set max)	Unit Steps	Unit Steps
Turn Acceleration	Vary from 0 (or factory set min) to 100 (or factory set max)	Unit Steps	Unit Steps
Turn Deceleration	Vary from 0 (or factory set min) to 100 (or factory set max)	Unit Steps	Unit Steps
Forward speed	Vary from 0 (or factory set min) to 100 (or factory set max)	1 % Steps	1 % Steps
Reverse Speed	Vary from 0 (or factory set min) to 100 (or factory set max)	1 % Steps	1 % Steps
Turn Speed	Vary from 0 (or factory set min) to 100 (or factory set max)	1 % Steps	1 % Steps
Sleep Timer	Period of time before control system" goes to sleep". (1 to 10 mins.)	1 min. steps	1 min. steps
Joystick Throw	Joystick deflection for full speed (20 % to 100%)	1 % steps	5 % Steps
Steer Correct	Veer compensation for mis-matched motors	-9 to +9	-9 to + 9
Read Timer	Displayed hours wheelchair in use	Yes	Yes
Read Fault Log	Displayed fault code history	Yes	Yes
Preset Control system	Set drive functions to factory preset values	Yes	Yes
Help Mode	On-line help text	Yes	Yes
Diagnostic	Reads fault code from Pilot+	Yes	Yes
Soft Reverse	Prevents wheels digging in when braking in reverse down a slope. Percentage of forward brake rate (25% to 100%)		1 % Steps
Current Limit	Maximum and minimum current outputs (20A to 80A)		A1 Steps
Foldback Temp	Reduce current at this temperature (25°C to 70°C) then decrease current linearly until shut down temperature is reached.		1°C steps`
Compensation	Match motor impedance for precise control (0 to 1 ).		5m Steps
Battery Menu	Match Tru Charge Display to loom resistance.(0 to 25m ).		1m steps
Park Brake Trip	For Chairs without brakes		YES/NO
Front Drive	Select algorithm for front wheel drive		YES/NO

Fast Brake Rate	Slam braking by pulling joystick in reverse (0 to 100%)		1 % Steps
Soft Stop	Controlled braking if control system switched off whilst driving		YES/NO
Inhibit	Polarity and latched operation of speed limit input		Low/High & Yes/No
Profiles	Set power Module to operate with drive profiles (1 to 5)		1.2.3.4 or 5
Swat Motors	Exchanges left and right motor outputs		YES/NO
Brake Voltage	Solenoid brake voltage (12/24v)		12 V or 24V
Min. Accel'n %	Vary from 0% to 100%		1 % Steps
Min Decel'n %	Vary from 0% to 100%		1 % Steps
Min Turn Acc. %	Vary from 0% to 100%		1 % Steps
Min Turn Dec.%	Vary from 0% to 100%		1 % Steps
Clear Timer	Reset elapsed timer		Yes/No
Erase Fault Log	Erases fault code history		Yes
Preset Engineering Values	Set engineering to factory preset values		Yes

## 2.4. Important Note

Resetting parameters to non compatible values could damage control systems and motors, and invalidate any warranties. Current Limit should never be set to a value greater than the values recommended for the Power Module you have, and Park Brake Trip should only be disabled on those chairs without solenoid brakes. Contact Penny & Giles if there is the slightest doubt. On a more general note, is possible to set up a control system so that is unsuitable for some users or even some wheelchairs, if you need any advice on programming, please do not hesitate to contact Penny & Giles.

## 3.0 Using the PPI

Please read this guide carefully before using the PP1 Programmer. Setting parameters to incorrect values could damage control systems and motors, and invalidate any warranties. In particular, Current Limit should never be set to a value great than the recommended control system maximum.

3.1 PP1b Keypad Layout & Description.

### 3.2. Connection

To program, you can connect the PP1 to the Pilot + via the charging socket on the Joystick Module, if the system is either on or off. You can also drive with PP1 connected.

Please note, for safety reasons, accessing some critical parameters will cause the control system to trip. This is indicated by the TruCharge display rippling up and down. This is intentional and the control system can be simply reset by switching off then on again.

To use the PP1 to view fault codes and messages, connect it to the control system when the control system has tripped. Note, if a trip occurs when the PP1 is already connected then no diagnostic information will appear.

If you wish to program but the PP1 is showing diagnostic information, press the ENTER key and the PP1 will go into programming mode.

**IMPORTANT: When the PPI is connected to the Pilot + the electromagnetic compatibility (E.M.C) performance of the wheelchair may be affected. Disconnect the PPI as soon as programming is complete and do not use PPI in environments, which are E.M.C. sensitive.**

## 4.0 Root Menu

The ROOT Menu, which is included in both the PP1a and PP1b contains all the parameters which set the normal drive characteristics of the wheelchair, it is also possible to read the fault log and elapsed time. Each parameter is explained in the following paragraphs.

### 4.1. Acceleration?

Adjusts the value for forward and reverse acceleration of the wheelchair from 0 to 100 in steps of 1.A. higher value gives faster acceleration. This programmed value of acceleration occurs when the Joystick Module has speed setting 5 selected. Its value at other settings depends on the value of the Min Accel'n % parameter, see section 5.15.

Some Power Modules may be factory programmed to limit the value of this parameter. If you want to set the value to be higher than this limit, contact Penny & Giles

### 4.2. Deceleration?

Adjusts the value for forward and reverse deceleration (or braking) of the wheelchair, from 0 to 100 in steps of 1.A higher value gives faster deceleration. This programmed value of deceleration occurs when the Joystick Module has speed setting 5 selected. Its value at other settings depends on the value of the **Min Decel'n %** parameter, see section 5.16.

Some Power Modules may be factory programmed to limit the value of this parameter. If you want to set the value to be higher than this limit, contact Penny & Giles

### 4.3 Turn Accel'n ?

Adjusts the value for turning acceleration of the wheelchair, from 0 to 100 in steps of 1.A higher value gives faster acceleration. This programmed value of acceleration occurs when the Joystick Module has speed setting 5 selected. Its value at other settings depends on the value of the Min Turn Acc. % parameter, see section 5.17.

Some Power Modules may be factory programmed to limit the value of this parameter. If you want to set the value to be higher than this limit, contact Penny & Giles

#### 4.4. Turn Decel'n?

Adjusts the value for turning deceleration (or braking) of the wheelchair, from 0 to 100 in steps of 1. A higher value gives faster deceleration. This programmed value of deceleration occurs when the Joystick Module has speed setting 5 selected. Its value at other settings depends on the value of the Min Turn Dec.% parameter, see section 5.18.

Some Power Modules may be factory programmed to limit the value of this parameter. If you want to set the value to be higher than this limit, contact Penny & Giles

#### 4.5. Forward Speed?

Adjusts the minimum and maximum value for forward speed of the wheelchair, from 0 to 100 % in steps of 1%. A higher value gives a faster speed. The minimum value occurs when the Joystick Module has speed setting 1 selected, and the maximum value occurs at speed setting 5.

Some Power Modules may be factory programmed to limit the value of this parameter. If you want to set the value to be higher than this limit, contact Penny & Giles

#### 4.6. Reverse Speed?

Adjusts the minimum and maximum value for reverse speed of the wheelchair, from 0 to 100 % in steps of 1%. A higher value gives a faster speed. The minimum value occurs when the Joystick Module has speed setting 1 selected, and the maximum value occurs at speed setting 5.

Some Power Modules may be factory programmed to limit the value of this parameter. If you want to set the value to be higher than this limit, contact Penny & Giles

#### 4.7. Turning Speed?

Adjusts the minimum and maximum value for turning speed of the wheelchair, from 0 to 100 % in steps of 1%. A higher value gives a faster speed. The minimum value occurs when the Joystick Module has speed setting 1 selected, and the maximum value occurs at speed setting 5.

Some Power Modules may be factory programmed to limit the value of this parameter. If you want to set the value to be higher than this limit, contact Penny & Giles

#### 4.8. Sleep Timer?

Sets the period of time before the control system will "go to sleep" if the joystick is not operated. The time can be set between 1 and 10 minutes in steps of 1 minute. If the time is set to 0 the system will never "go to sleep"

#### 4.9 Joystick Throw?

This allows you to program the control system so that full speed can be reached with a reduced joystick movement (throw). This is particularly useful for wheelchair user with limited hand or arm movement.

The adjustment can be made manually or by programming actual values

#### 4.9.1. Manual Adjustment

when the ENTER key is pressed the current setting for joystick in the forward direction will be Displayed. If the joystick is displaced in the forward direction beyond 25% then the actual joystick position will be displaced. Operation of the ENTER key will store the value displaced on the screen. This method can therefore be used to interactively set up the joystick throw the wheelchair user. This method can therefore be used to interactively set up the joystick throw with wheelchair user.

The process is repeated for joystick reverse, left and right positions.

#### 4.9.2. Programming Adjustment.

When the ENTER key is pressed the current setting for joystick throw in the forward direction will be displayed. Operation of the UP or DOWN keys will change this setting, operation of the ENTER key will store the setting.

The process is repeated for joystick reverse, left and right positions.

#### 4.10. Steer Correct?

This factor compensates for any mismatching of motors to ensure that the wheelchair drives directly forward when the control system's joystick is being pushed directly forward.

It is normally set to zero but may be varied from -9 to +9 in increments of 1. if the chair is veering to the left, you should increase the setting, if the chair veers to the right, decrease the setting, If Swap Motors is set, this logic will be reversed, see section 5.13.

#### 4.11 Read Timer?

The Pilot +has a timer, which records how long the wheelchair is in use. The time runs whenever the joystick is moved away from the center position, and stop when the joystick is returned. The timer records the number of hours the wheelchair has been in use.

#### 4.12 Read Fault Log?

The Pilot + has a fault log facility which store the number of occurrence of the last eight faults.

This allows you to view the contents. The display format is as below:

```
1: Code 2C00, # 1
2: Code 3C00, #3
No more entries
```

This reads line by line as.

```
Line 1 – fault code 2C00 has occurred once
Line 2 – fault code 3CC has occurred three times
Only two faults types recorded.
```

To clear the fault log refer to section 5.21.

#### 4.13 Preset Unit?

Selecting this sets all ROOT menu parameters to their default values. These default values are decided between Penny & Giles and the wheelchair manufacturer



## 5.0 Engineer Menu?

Selection of this enters the engineering menu and allows you to adjust the technical performance parameters or functions of the control system. Each parameter or function is described below.

### 5.1 Soft Reverse?

This sets the reverse braking rate. Reverse braking is normally 70% of forward braking to prevent the chair's tendency to topple when stopping in reverse on a gradient

You can set the reverse braking between 25% and 100% of forward braking.

### 5.2 Current Limit?

This sets the maximum and minimum current output for the control system. The current output is dependent on the internal temperature of the Power Module. Graph A (below) show the relationship.

Pilot+ Power Modules are available in two power ratings – 50A and 80A. The table below shows the recommended maximum to minimum relationship.

Max Current Limit	Min. Current Limit
50A	40A
80A	60A

You can set the maximum and minimum current outputs between 20A and the maximum permitted upper value in steps of 1A.

### 5.3. Temp. Foldback?

This is the internal Power Module temperature at which the current starts to reduce, see Graph A. The table below shows the maximum value of temperature for each Power Module type.

Max Current Limit	Temp. Foldback
50A	55°C
80A	55°C

**IMPORTANT-** the temperature value should never be set to more than the maximum possible for each control system type. Doing so will invalidate the warranty and affect the long term reliability of the control system.

## 5.4 Timed Foldback?

This function allows a measure of protection for motors when they get into a stalled condition. You can set a 'Stall Time' of between 5 seconds and 10 minutes in 4 second increments after which time the maximum current limit is reduced to a percentage of the maximum current. This percentage (Foldback%) may be set between 25% and 100% of the current limit maximum in 1% steps.

After a fixed Reset Period of 5 x (Stall Time), the current limit will be allowed to return to the current limit maximum, if demanded. This reset period is to allow the motor (s) sufficient time to cool.

e.g. Power Module has current limit of 80A, stall time of 15 seconds of foldback % to 25%. This means that, if the motors are stalled, after 15 seconds the current output of the Power Module will reduce to 25% of 80A = 20A. After 5 x 15s = 75s the current output will return to 80A.

## 5.5. Compensation?

This matches the control system to different motor types in order to achieve optimal performance and control. Penny & Giles recommended that you set this value to not more than 70% of the resistance of the motor armature and all cables and connectors to it.

**IMPORTANT – never set to greater than 70%**

Motor manufacturer should be able to supply figures for armature resistance, and typical cable and connectors would be about 40m .

## 5.6. Battery Menu?

### 5.6.1 Battery Cable?

This sets the value of cable and connector resistance between the control system and the batteries. The value corresponds to the total resistance in both the positive and negative paths.

You can set this between 0m and 255m in steps of 1m .

### 5.6.2 Gauge Cal?

This allows further fine calibration of the TruCharge battery gauge. This is normally set at the factory and should not need adjustment. Please contact Penny & Giles if you are considering altering this factor.

### 5.6.3 Back to E Menu?

This returns you to the ENGINEER Menu

## 5.7. Park Brake Trip?

This tells the control system whether or not to trip if one or both of the solenoid brakes become disconnected or are not fitted. You can turn this function on or off.

**IMPORTANT- this function should only ever be turned off if there are no solenoid brakes fitted to the wheelchair.**

## 5.8. Front Drive?

This selects special front wheel drive control software. You can turn this on or off.

It is possible for wheelchair manufacturer, in conjunction with Penny & Giles to change toe driving characteristics of the front wheel drive software, please contact Penny & Giles for further details.

### 5.9. Fast Brake Rate?

This sets the declaration for fast braking. Fast braking is when the joystick is pulled to the reverse position to effect a faster stop. You can set the fast brake rate between 0 and 100. If this value is set lower than the normal Deceleration rate, then the latter rate will be used.

### 5.10. Soft Stop?

This selects whether the soft-stop facility is enabled. Soft-stop means that if you switch the control system off whilst driving, the wheelchair will steadily decelerate to standstill.

You can turn this function on or off.

**IMPORTANT – if this function is on, you must ensure that the emergency stopping distance within the distance specified for the country in which the wheelchair will be used. TÜV Product Service (Germany) specify the distance to be as stated in prEN12184.**

### 5.11 Set Inhibit?

This sets the operation of the speed limit, input. This input can also be used as an inhibit input the inhibit speed limited. Value is set to zero, see chapter section 3.5. for more details.

There are two options associated with this function-polarity and latching.

**Active low** – This is the polarity of the input. It can be set to yes or no. The table below shows the effect of the input on wheelchair speed for the two settings.

Speed Limit input Resistance	Inhibit Polarity Low (active low = yes)	Inhibit Polarity High (active low = no)
Short circuit	Inhibit Speed	Normal Speed
22K ±10%	Slow Speed	Mid Speed
100 ±10 %	Mid Speed	Slow Speed
Open circuit	Normal Speed	Inhibit Speed

**Latched** – this determines whether the control system trips when an inhibit signal (inhibit speed=0) is received. It can be set to yes or no. Yes gives a trip condition and the system must be switched off and again to reset. No means that drive can be resumed as soon as the inhibit signal is removed.

This setting for inhibit, Slow and Mid speed limits are factory programmable, if you want to alter these values please contact Penny & Giles.

### 5.12 Profiles?

This function can only be used with customer specific joystick Modules which support drive profiles. The Pilot+ generic joystick Modules are not designed to operate with drive profiles. Consequently, this value should be set to 0. For further information, please contact Penny & Giles.

### 5.13. Swap Motors?

This swaps the motor output connections, M1 and M2, on the Power Module. Normally M1 is for the left motor and M2 for the right motor.

You can select between yes and no. If set to yes, M1 will be for the right motor and M2 for the left motor, if set to no, the normal condition will apply.

Note, if you swap the motor connections the truCharge motor diagnostic information will need to be interpreted differently, see chapter 1 section 8.5. The function of Steel Correct will also be reversed. See section 4.10.

#### 5.14 Brake Voltage?

This sets the voltage output from the Power Module to the Solenoid brakes, you can select either 12V or 24v.

**WARNING:** It is essential that the control system is programmed for the correct brake voltage. If it is not damage may occur to the brakes or drive performance of the wheelchair may be affected.

#### 5.15. Min Accel'n?

Adjusts the minimum value for forward and reverse acceleration of the wheelchair. It is programmed in increments of 1% of the Acceleration value. This percentage of the Acceleration value occurs when the joystick Module' speed setting is at 1. For example: if Acceleration is set at 80 and Min Accel'n % is set at 25% then when speed setting is 1, acceleration will be 25% X80=20 and when the speed setting is 5, the acceleration will be 80. Speed settings, 2,3 and 4 will interpolate linearly between 20 and 80. i.e. acceleration values of 35, 50 and 65 respectively. If min Accel'n % is set at 100% then acceleration will not vary as the speed setting is changed.

Some Power Module may be factory programmed to limit the value of this parameter. If you want to set the value outside these limits, contact Penny & Giles.

#### 5.16 Min Decel'n %

Adjusts the minimum value for forward and reverse acceleration of the wheelchair. It is programmed in increments of 1% of the Deceleration value. This percentage of the Deceleration value occurs when the joystick Module' speed setting is at 1. For example: if Deceleration is set at 80 and Min Decel'n % is set at 25% then when speed setting is 1, Deceleration will be 25% X80=20 and when the speed setting is 5, the Deceleration will be 80. Speed settings, 2,3 and 4 will interpolate linearly between 20 and 80. i.e. Deceleration values of 35, 50 and 65 respectively. If min Decel'n % is set at 100% then Deceleration will not vary as the speed setting is changed.

Some Power Module may be factory programmed to limit the value of this parameter. If you want to set the value outside these limits, contact Penny & Giles.

#### 5.17 Min Turn Acc. %?

Adjusts the minimum value for turn acceleration of the wheelchair. It is programmed in increments of 1% of the Turn Accel'n value. This percentage of Turn Accel'n value occurs when the joystick Module's Speed setting is at 1. For example if Turn Accel'n is set at 80 and Min Turn Acc.% is set at 25% then when the speed setting is 1, acceleration will be 25%x80=20 and when the speed setting is 5, the acceleration will be 80. Speed setting 2,3 and 4 will interpolate linearly between 20 and 80 i.e. turn acceleration values of 35, 65 respectively. If Min Turn Acc% is set at 100% then acceleration will not vary as the speed setting is change.

Some Power Module may be factory programmed to limit the value of this parameter. If you want to set the value outside these limits, contact Penny & Giles.

#### 5.18 Min Turn Dec.%?

Adjusts the minimum value for turn deceleration of the wheelchair. It is programmed in increments of 1% of the Turn Decel'n value. This percentage of Turn Decel'n value occurs when the joystick Module's Speed setting is at 1. For example if Turn Decel'n is set at 80 and Min Turn Dec.% is set at 25% then when the speed setting is 1, acceleration will be 25%x80=20 and when the speed setting is 5, the acceleration will be 80. Speed setting 2,3 and 4 will interpolate linearly between 20 and 80 i.e. turn deceleration values of 35, 65 respectively. If Min Turn Dec.% is set at 100% then acceleration will not vary as the speed setting is change.

Some Power Module may be factory programmed to limit the value of this parameter. If you want to set the value outside these limits, contact Penny & Giles.

#### 5.19 Clear Timer?

This allows you to reset the timer to 0 hours.

#### 5.20 Erase Fault Log?

This allows you to clear the fault log after a successful repair.

#### 5.21. Preset Eng. Values?

Selection this sets all ENGINNER menu parameters to their default values.

#### 5.22 Back to root?

This takes you back to the ROOT menu.

## **PILOT SERIES POWERCHAIR CONTROLLER**

## **1.0. Introduction**

The operation of the Pilot series of wheelchair controllers is simple and easy to understand. The controller incorporates state of the art electronics, the result of many years research, to provide you with ease of use and a very high level of safety. In common with other electronic equipment, correct handling and operation of the unit will ensure maximum reliability.

Please read this user chapter carefully- it will help you keep your wheelchair reliable and safe.

## **2.0. General**

### **2.1. Handling**

Avoid knocking your controller and especially the joystick. Be careful not to strike obstacles with the controller or joystick when you drive. Never drop the controller.

When transporting your wheelchair, make sure that the controller is well protected. Avoid damage to cables.

### **2.2. Operating Conditions**

Your controller uses industrial grade components throughout, ensuring reliable operation in a wide range of conditions. However, you will improve the reliability of the controller if you keep exposure to extreme conditions to a minimum.

Do not expose your controller or its components to damp for prolonged periods. If the controller becomes contaminated with food or drink clean it off as soon as possible.

### **2.3. Cleaning**

Clean the controller and joystick with a cloth dampened with washing up liquid mixed with water. Be careful when cleaning the joystick.

Never use abrasive or spirit based cleaners.

## **3.0 Controls**

### **3.1. Main Power Switch and Power Indicator**

The main power switch applies power to the controller electronics, which in turn supply power to the motors. Do not use the main power switch to stop the wheelchair to stop the wheelchair unless there is an emergency. (If you do, you may shorten the life of the wheelchair drive components).

The battery gauge shows you that the controller is switched on. It also indicates the operating status of the wheelchair. Details are given in section 8.





### 3.2 Joystick

This joystick controls the speed and direction of the wheel chair, the further you push the joystick from the rest position. The faster your wheelchair will move. When you release the joystick the brakes are applied automatically.

### 3.3. Speed Control

This control sets the maximum speed the wheelchair. Turn the knob clockwise to increase the speed or anti-clockwise to decrease the speed.

The speed control is programmable. Refer to section 10 for details.

## 4.0 Getting Ready to Drive.

Check that the speed is turned to a position, which suits you.

Press the main power switch. The battery gauge will blink and then turn on after a second.

Push the joystick to control the speed and direction of the wheelchair.

Please note that if you push the joystick after you turn on the controller, the battery gauge illumination will 'ripple' up and down and the wheelchair will not be allowed to move. You must release the joystick to resume normal operation. If you do not release the joystick within five seconds the wheelchair will not be able to move, even if you release the joystick and push it again. The battery gauge will then flash rapidly. You can clear this condition by switching the controller off and of again.

If you do not push the joystick when you switch on the controller and the battery gauge flashes rapidly then there may be a fault. Refer to section 8 for details.

## 5.0 Tips for Using Your Controller

### 5.1. Driving - General

Make sure that the controller is mounted securely and the joystick position is correct. The hand limb you use to operate the joystick be supported, for example by the wheelchair arm pad. Do not use the joystick as the sole support for your hand or limb. Wheelchair movements and bumps could upset your control.

### 5.2. Driving Technique

The controller interprets your joystick movements and produces appropriate movement of your wheelchair. You will need very little concentration to control the wheelchair, which is especially useful if you are inexperienced. One popular technique is to simply point the joystick in the direction you want to go. The wheelchair will 'home-in' on the direction you push the joystick.

The further you push joystick away from the rest position, the faster the wheelchair will go.

The intelligent speed control system minimises the effect of the slopes and different types of terrain.

## 6.0 Precautions for Use

Note: In the event of the wheelchair moving in an unexpected way release the joystick. This action will stop the wheelchair under any circumstances.

## 6.1 Hazards

Do not drive the wheelchair.

- i) Beyond restrictions indicated in your wheelchair user manual, for example maximum inclines, curb height etc.
- ii) In places or on surface where a loss of wheel grip could be hazardous, for example on wet grassy slopes.
- iii) If you know that the controller or other crucial components require repair.

**WARNING: Although the Pilot controller is designed to be extremely reliable and each unit is rigorously tested during manufacture, the possibility of a system malfunction always exists (however small the probability). Under some conditions of system malfunction the controller must (for safety reasons) stop the chair instantaneously. If there is any possibility of the user falling out of the chair as a result of a sudden braking action, it is imperative that a restraining device such as a seat belt is supplied with the wheelchair and that it is use at all times when the wheelchair is in motion. Penny & Giles accept no liability for losses of any kind arising from the unexpected stopping of the wheelchair or arising from the improper use of the wheelchair or controller.**

## 7.0 Safety Checks

The electronic circuits in your controller have been designed to be extremely safe and reliable. This no-board microcomputer carries out safety at up to 100 times per second. To supplement this safety monitoring you should carry out the following periodic checks.

If the control system fails any of these checks, do not use the wheelchair and contact your service agent.

### 7.1. Daily Checks

Joystick: with the controller switched off, check that the joystick is not bent or damaged and that it returns to the centre when you push and release it. If there is a problem do not continue with the safety check and contact your service agent.

### 7.2. Weekly Checks

Parking brake: This test should be carried out on level floor with at least one meter clear space around the wheelchair.

- i) Switch on the Controller
- ii) Check that the battery gauge remains on, or flashes slowly, after one second.
- iii) Push the joystick slowly forwards until you hear the parking brakes operate. The chair may start to move.
- iv) Immediately release the joystick. You must be able to hear each parking brake operate within a few seconds.
- v) Repeat the test a further three times, pushing the joystick slowly backwards, left and right.

**Connectors:** Make sure that all cable and connectors for damage.

**Cables:** Check the condition of all cables and connectors for damage.

**Joystick gaiter:** Check the thin rubber or boot, around the base of the joystick shaft, for damage or splitting. Check visually only, do not handle the gaiter.

**Mounting:** Make sure that all the components of the control system are securely mounted. Do not over tighten any securing screws.

### 7.3. Servicing

To ensure continued satisfactory service, we suggest you have your wheelchair and control system inspected by your service agent after a period of 1 year from commencement of service. Contact your service agent for details when the inspection is due.

## 8.0 Status Indication

The battery gauge will indicate the status of the controller.

Please note that a number of supposedly faulty controllers returned to us are subsequently found to operate correctly. This indicates that many faults are due to the wheelchair problems rather than the controller.

### 8.1. Battery Gauge Steady

This indicate that all is well

### 8.2. Battery Gauge Flashes Slowly

The Controller is functioning correctly, but you should charge the battery as soon as possible.

### 8.3. Battery Gauge Flashes Rapidly (even with the joystick released)

This controller safety circuits have operated and the controllers has been prevented from moving the wheelchair.

This indicates that there is fault. Please follow this procedure.

- i) Switch off the controller.
- ii) Make sure that all connectors on the wheelchair and the controller are mated securely.
- iii) Check the condition of the battery.
- iv) if you can't find the problem, try using the self-help guide give in section 8.4.
- v) Switch on the controller again and try to drive the wheelchair. If the safety circuits operate again, switch off and do not try to use the wheelchair. Contact your service agent.

### 8.4. Self Help Guide.

If a fault occurs, you can find our what has happened by counting the number of bars on the battery gauge that are flashing.

Here is a list of self-help actions. Try to user this list before you contact your service agent. Go to the number in the list, which matches number of flashing bars and follow the instructions.

**1 bar:** The battery needs charging or there is a bad connection to the battery. Check the connections to the battery and the check the controller power connector. If the connections are good, try charging the battery.

**2 bar:** The left hand motor has a bad connection. Make sure that the motors is connected properly an the controller connectors are secure.

**3 bar:** The left hand motor has a short circuit battery connection. Contact your service agent.

**4 bar:** The right hand motor has a bad connection. Make sure that the motor is connected properly and the controller connectors are secure.

**5 bar:** The right hand motor has a short circuit to a battery connection.. Contact your service agent.

**6 bar:** The battery charger is preventing the controller from driving the wheelchair. Disconnect the charger from the wheelchair.

**7 bar:** A joystick is indicated. Make sure that the joystick is in the rest position before switching on the controller.

**8 bar:** A controller fault is indicated. Make sure the controller connections are secure.

**9 bar:** The parking brakes have a bad connection. Check the parking brake and motor connections. Make sure the controller connections are secure.

**10 bar:** An excessive voltage has been applied to the controller. This is usually caused by a poor battery connection. Check the battery and controller connections.

## 8.5. Slow or Sluggish Movement

If the wheelchair does not travel at full speed or does not respond quickly enough, and the battery condition is good, check the position of the speed control. If adjusting the speed control does not remedy the problem then there may be a non-hazardous fault.

Contact your service agent.

## 9.0 Battery Gauge

The battery gauge is included to let you know how much charge is left in your batteries. The best way for you to use the gauge is to learn how it behaves as you drive the wheelchair. Like the fuel gauge in a car, it is not completely accurate, but it will help you avoid running out of "fuel".

The battery gauge work in the following way:

When you switch on the controller, the battery gauge shows an estimate of the remaining battery charge. The battery gauge gives you a more accurate reading about a minute after you start driving the wheelchair.

Note: When you replace worn out batteries, fit the type recommended by the wheelchair manufacturer. If you use another type the battery gauge may be inaccurate.

The amount of charge in your batteries depends on a number of factors. Including the way you use your wheelchair. The temperature of the batteries, their age and the way they are made. These factors will affect the distance you can travel in your wheelchair. All wheelchair batteries will gradually lose their capacity as they age.

The most important factor that reduces the life of your batteries is the amount of charge you take from the batteries before you recharge them. Battery life is also reduced by the number of times you charge and discharge the batteries.

To make your batteries last longer, do not allow them to become completely flat. Always recharge your batteries promptly after they are discharged.

If your battery gauge reading seems to fall more quickly than usual, your batteries may be worn out.

## 10.0 Programming

If you find that you cannot find a position of the speed control that suits you, the controller can be programmed to meet your needs.

The PP1 is a small hand-held unit, which can be plugged into your controller to alter the program. A PP1 may be included with your wheelchair. If a PP1 is not included, your wheelchair distributor or service agent or wheelchair manufacture will be able to program your controller for you.

If you have a PP1, read the PP1 use guide before you use it.

If you re-program your controller, make sure that you observe any restrictions given in your wheelchair user manual. Note any changes you make for further reference.

**WARNING: Programming should only be conducted by healthcare professional with in depth knowledge of Penny & Giles electronic controllers. Incorrect programming could result in an unsafe-up of a wheelchair for a user. Penny & Giles accept no liability for losses of any kind of the programming of the controller is altered from factory pre-set values.**

## 11.0 Joystick Knobs

The knob fitted to your joystick is suitable for most applications. If you would prefer another type, there is a range of alternatives please contact your wheelchair distributor or manufactures for advise. Do not, replace the joystick knob with any unauthorised-it may cause hazardous operation.

## 12.0 Servicing

All repairs and servicing must be carried out by service personnel. Opening or making any unauthorised or modifications to the controllers or its components will invalidate any warranty and may result is hazards to yourself of other people, and strictly forbidden.

WARNING: Penny & Giles accept no liability for losses of any kind arising from unauthorised opening. Adjustment or modifications to the Pilot controller.

**PILOT SERIES DIGITAL POWERCHAIR CONTROLLER**  
**CHAPTER 2 PROGRAMMING**

## 1.0 Programming for Wheelchair Controller

The main advantage of using programmable controllers is that they can be easily tailored to the specific needs and capabilities of particular wheelchair user while taking into account the safe performance characteristics of the wheelchair being used. This means that powered wheelchair configured with Penny & Giles Pilot controllers can be readily programmed to be safe under normal driving conditions and also feel secure and comfortable to the use.

The programmable controller achieves this great flexibility by referring to a set of internal parameters, which govern factors such as the wheelchair's speed. These parameters can be changed over a wide span to suit different chairs and users a simple, hand-held programmer.

### 1.1 Important Note

It is possible to set up a controller so that is unsuitable for users and possibly even some chairs. Take care when programming a controller and if you need any advice in programming or selecting values, please do not hesitate to contact Penny & Giles.

**WARNING: Programming should only be conducted by healthcare professional with in depth knowledge of Penny & Giles electronic controllers. Incorrect programming could result in an unsafe-up of a wheelchair for a user. Penny & Giles accept no liability for losses of any kind of the programming of the controller is altered from factory pre-set values.**

## 2.0 PPI Pilot Programmer

The PP1 is the handheld programmer that Penny & Giles supply for their Pilot series of wheelchair controllers. Primarily intended for the specialised design and test requirements of wheelchair manufacturers and engineers the PP1 takes full advantage of the complete programmability of the Pilot, offering functions not available with less sophisticated controllers designs.

The PP1 is a menu driven programmer which plugs directly into controller, and is available in two configurations, suited to different applications.

### 2.1 Basic PP1 Programmer

The most basic programmer version - the PP1a- is intended for purpose use. It can set upper and lower limits for all of the key controller speed and acceleration characteristics, and allows different settings to be tried out while the programmer is still plugged into the controller. A context-sensitive help function is available to guide users through the menus and the PP1 can also display error message from the Pilot controller, allowing any problems with the wheelchair electrical system to be identified and corrected quickly.

### 2.2 Engineering Version.

The engineering Version (PP1b) offers all the PP1a features but also includes a suite of advanced functions for designers, such as matching the controller to motor impedance, setting maximum drive current, and enabling front or rear wheel drive algorithms. Clearly, the PP1b is a very powerful tool for prototype design work. However, users who program parameters incorrectly do run the risk of damaging controllers or motors, so it should be used by experts in wheelchair electrical systems.

## 2.3. PP1 Specifications

FUNCTIONS	NOTES	PP1a	
Set Acceleration	Vary from 0 to 100.	Unit Steps	Unit Steps
Set Deceleration	Vary from 0 to 100.	Unit Steps	Unit Steps
Set Turn Acceleration	Vary from 0 to 100.	Unit Steps	Unit Steps
Set Turn Deceleration	Vary from 0 to 100.	Unit Steps	Unit Steps
Set Forward speed	Vary from 0 to 100.	1 % Steps	1 % Steps
Set Reverse Speed	Vary from 0 to 100.	1 % Steps	1 % Steps
Set Turn Speed	Vary from 0 to 100.	1 % Steps	1 % Steps
Read Fault Log	Display fault code history	1 min. steps	1 min. steps
Preset Controller	Set drive functions to factory preset values	1 % steps	5 % Steps
Help Mode	On-line help test	-9 to +9	-9 to + 9
Diagnostics	Reads fault code from Pilot	Yes	Yes
Steer Correction	Compensate for mismatched motors	Yes	Yes
Set Soft Reverse	Prevents wheels digging in when braking in reverse down a slope. Percentage of forward brake rate (25% to 40A)	Yes	Yes
Set Current Limit	Maximum and minimum current outputs (20A to 40A)	Yes	Yes
Set Foldback Temp	Reduce current at this temperature (25°C to 70°C), then decrease current linearly until shut down temperature is reached.	Yes	Yes
Set Foldback Time	Reduce current (25% to 100%) after stall time (5s to 10mins) to protect motors		1 % Steps
Set Compensation	Match motor impedance for precise control (0 to 1).		A1 Steps
Set Battery Menu	Match TruCharge display to loom resistance. ( 0 to 255m ).		1°C steps`
Set Brake Triple Disable <sup>(1)</sup>	For chair without brakes		5m Steps
Set Front Wheel Drive	Vary from 0% to 100%.		1m steps
Min Acceleration	Vary from 0% to 100%		YES/NO
Min Deceleration	Vary from 0% to 100%		YES/NO
Min Turn Acceleration	Vary from 0% to 100%		1 % Steps
Min Turn Deceleration	Vary from 0% to 100%		YES/NO
Erase Fault Log	Erase fault code history		Low/High & Yes/No
Preset Engineering Values	Set engineering functions to factory preset values		1.2.3.4 or 5

## 2.4 Important Note (1)

Resetting these parameters to non-compatible values could damage controllers and motors, and invalidate any warranties. Current Limit should never be set to a value greater than the recommended controller maximum and Brake & Trip should only be disabled on those chairs without brakes. Contact Penny & Giles if there is the slightest doubt. On a more general note it is possible to set up a controller so that it is unsuitable for some users or even some chairs, if you need and advice on programming, please do not hesitate to contact Penny & Giles.



### **3.0 Using the PP1b**

Please read this guide carefully before using the PP1b Programmer. Setting parameters to incorrect value could damage controllers and motors, and invalidate any warranties, In particular, Current Limited should never be set to a value than the recommended controller maximum and Park Brake Trip should only be disabled on chairs without brakes.

#### 3.1 PP1b Keypad Layout & Description.

### 3.2. Connection

The PP1 reacts differently depending on status of the controller when the PP1 is connected.

- i) If the controller is on and working- simply plug the PP1 into the controller. Its ROOT menu will be displayed and the PP1 may be used to change the programming parameters of the controller. Provided no engineering functions are altered, the chair may be driven with the programmer still attached. If any engineering function are altered, then the controller will be inhibited from driving until the controller has been turned off and then on.
- ii) If the controller is on and on a tripped' state – plug the PP1 in. The fault message relating to the trip will automatically be displayed. Once the message has been read, you can select the Enter key to display the ROOT menu and begin programming the controller.
- iii) If the controller is off. Plug the PP1 in and it will display a “no connection” message. If the controller is now turned on, the PP1 will enter its ROOT menu.

**IMPORTANT – When the PPI is connected to the Pilot, the electromagnetic compatibility (EMC) performance of the wheelchair may be affected. Disconnect the PPI as soon as programming is complete and do not use the PPI in environment, which are EMC sensitive.**

## 4.0 Root Menu

The ROOT menu contains all the parameters, which set the normal drive characteristics of the wheelchair. Each parameter is explained in the following paragraphs.

### 4.1 Acceleration?

Adjusts the value of forward and reverse acceleration of the wheelchair, increments of 1 %. This value occurs when the controller's speed control potentiometer is fully clockwise. Its value at other settings of the speed control depends on the setting of the Min Acceleration parameter (see later).

### 4.2. Deceleration?

Adjusts the value of forward and reverse deceleration of the wheelchair, increments of 1 %. This value occurs when the controller's speed control potentiometer is fully clockwise. Its value at other settings of the speed control depends on the setting of the Min Deceleration parameter (see later).

### 4.3. Turn Accel'n?

Adjusts the value of forward and turn deceleration of the wheelchair, increments of 1 %. This value occurs when the controller's speed control potentiometer is fully clockwise. Its value at other settings of the speed control depends on the setting of the Min turn acceleration parameter (see later).

### 4.4. Turn Decel'n?

Adjusts the value of forward and turn deceleration of the wheelchair, increments of 1 %. This value occurs when the controller's speed control potentiometer is fully clockwise. Its value at other settings of the speed control depends on the setting of the Min Turn Deceleration parameter (see later).

### 4.5 Forward Speed?

Adjusts of the minimum and maximum values for forward speed of the wheelchair, in increments of 10%. The maximum value occurs when the controller's speed control potentiometer is fully clockwise, and the minimum occurs when the speed control potentiometer is fully anti clockwise.

#### 4.6. Reverse Speed?

Adjusts of the values for reverse speed of the wheelchair, in increments of 10%. The maximum value occurs when the controller's speed control potentiometer is fully clockwise. The minimum value is automatically scaled in relationship to the forward speed setting and calculated as below.

$$\text{Min. rev} = \text{max reverse} \times \frac{\text{min forward}}{\text{max forward}}$$

#### 4.7. Turing Speed?

Adjusts the minimum and maximum values for turning speed of the wheelchair, in increments of 10%. The maximum value occurs when the controller's speed control potentiometer is fully clockwise, and the minimum occurs when the speed control potentiometer is fully anti-clockwise.

#### 4.8. Read Fault Log?

The pilot has a fault log facility, which stores the number of occurrences of the last eight faults.

This allows you to view the contents. The display format is a below:

```
1: Code 2C00, # 1
2: Code 3C00 # 3
No more entries
```

This reads line by line as.

```
Line 1 – fault code 2C00 has occurred once
Line 2 – fault code 3C00 has occurred three times
Only two fault types recorded.
```

#### 4.9. Preset Unit?

Selecting this sets all ROOT menu parameters to their default values.

### 5.0 Engineering Menu?

Selection of this enters the engineering menu and allows you to adjust the technical performance parameters of function of the controller. Each parameter of function is described below.

#### 5.1 Steer Correct?

This factor compensates for any mismatching of motors to ensure that the wheelchair drives directly forward when controller's joystick is being pushed directly forward.

It is normally set to zero but may be varied from -9 to +9 in increments of 1. If the chair is veering to the left, you should increase the setting of the chair veers to the right, decrease the setting.

#### 5.2. Soft Reverse?

This sets the reverse braking rate. Reverse braking is normally 70% of forward braking to prevent the chair's tendency to topple when stopping in reverse on a gradient.

You can set the reverse braking between 25% and 100% of forward braking.

### 5.3. Current Limit?

This sets the maximum and minimum current output for the controller. The current output is dependent on the internal temperature of the controller. Graph a (below) shows the relationship.

Pilot controllers come in two maximum current families –25A and 40A. The table below shows the recommended maximum to minimum relationships.

<u>Max current limit</u>	<u>Min current limit</u>
25A	25A
40A	30A

You can set the maximum and minimum current outputs between 20A and the maximum permitted upper value in steps of 1 A.

### 5.4. Temp. Foldback ?

This is the internal controller temperature at which the current output starts to reduce, see Graph A. The table below shows the maximum value of temperature for each controller type.

<u>Max current limit</u>	<u>Temp Foldback</u>
25A	55° C
40	55° C

**IMPORTANT- the temperature value should never be set to more than the maximum possible for each controller type. Doing so will invalidate the warranty and affect the long term reliability of the controller.**

### 5.5. Timed Foldback ?

This function allows measure of protection for motors when they get into a stalled condition. You can set a 'Stall Time' of between 5 seconds and 10 minute in 5 increments after which time the maximum current limit is reduced to a percentage of the maximum current. This percentage (Foldback%) may be set between 25% and 100% of the current maximum in 1% steps.

After fixed Reset Period of 5 x (Stall time), the current limit will be allowed to return to the current limit maximum, if demanded. This reset period is to allow the motor(s) sufficient time to cool.

## 5.6 Compensation ?

This matches the controllers to different motor types in order to achieve optimal performance and control. Penny & Giles recommend that you set this value to not more than 70% of the resistance of the motor armature and all cables and connectors to it.

**IMPORTANT - never set to greater than 70%.**

Motor manufacturer should be able to supply figures for armature resistance, and typical cable and connectors would be about 40m .

## 5.7 Battery Menu ?

### 5.7.1. Battery Cable ?

This sets the value of cable and connector resistance between the controller and the batteries. The value corresponds to the both the positive and negative paths.

You can set this between 0mΩ and 255 mΩ in steps of 1mΩ.

### 5.7.2. Gauge Cal?

This allows further fine calibration of the TruCharge battery gauge. This is normally set at the factory and should not need adjustment. Please contact Penny & Giles if you are considering altering this factor.

### 5.7.3 Back to E Menu ?

This returns you to the ENGINEER Menu.

## 5.8 Park Brake Trip ?

This tells the controller whether or not to trip if the solenoid brake is disconnected or not fitted. You can turn this function on or off.

**IMPROTANT - this function should only never ever be turned off if there are no solenoid brakes fitted to this function on or off.**

## 5.9. Front Drive ?

This selects special front wheel drive control software. You can turn this on or off.

## 5.10 Min Accel'n % ?

Adjusts the minimum value for forward and reverse acceleration of the wheelchair. It is programmed in increments of 1% of the Accel'n value. This percentage of Accel'n value occurs when the controller's speed control potentiometer is turned fully anti-clockwise. For example: if Accel'n is set at 90 and Min Accel'n is set at 50% x 90=45, when the control is turned fully clockwise, the acceleration will be 90. Intermediate positions of the speed control will interpolate linearly between 45 and 90. if Min Accel'n set at 100% then acceleration will not vary as the speed control's setting is changed.

## 5.11 Min Decel'n % ?

Adjusts the minimum value for forward and reverse deceleration of the wheelchair. It is programmed in increments of 1% of the Decel'n value. This percentage of Decel'n value occurs when the controller's speed control potentiometer is turned fully anti-clockwise. For example: if Decel'n is set at 90 and Min Accel'n is set at 50% x 90=45, when the control is turned fully clockwise, the deceleration will be 90. Intermediate positions of the speed control will interpolate linearly between 45 and 90. if Min Decel'n set at 100% then deceleration will not vary as the speed control's setting is changed.

### 5.12. Min Turn Accel'n % ?

Adjusts the minimum value for turn acceleration of the wheelchair. It is programmed in increments of 1 % of the Turn Accel'n value. This percentage of Trun Accel'n value occurs when the controller' speed control potentiometer is turned fully anti-clockwise. For example: if Turn Accel'n is set at 90 and Min Turn Accel'n is set at 50% then when the speed control is turned completely anti clockwise turn acceleration will be  $50\% \times 90 = 45$ , when the speed control is turned fully clockwise, the turn acceleration will be 90. Intermediate positions of the speed control will interpolate linearly between 45 and 90. If Min Turn Accel'n is set at 100% then turn acceleration will not vary as the speed control's setting is changed.

### 5.13. Min Turn Decel'n ?

Adjusts the minimum value for turn deceleration of the wheelchair. It is programmed in increments of 1% of the Turn Decel'n value. This percentage of Turn Decel'n value occurs when the controller's speed control potentiometer is turned fully anti-clockwise. For example: if Turn Decel'n is set at 90 an Min Turn Decel'n is set at 50% then when the speed control is turned completely anti-clockwise turn deceleration will be  $50\% \times 90 = 45$ , when the speed control is turned fully clockwise, the turn deceleration will be 90. Intermediate positions of the speed control will interpolate linearly between 45 and 90. If min Turn Decel'n set at 100% then turn deceleration will not vary as the speed control's setting is changed.

### 5.14. Erase Fault Log?

This allows you to clear the fault log after a successful repair.

### 5.15. Preset Eng Values ?

Selection this seta all ENGINEERING menu parameters to their default values.

### 5.16 Back to root ?

This takes you back to the ROOT menu.

## CONTROLLER INTERFACE UNITS

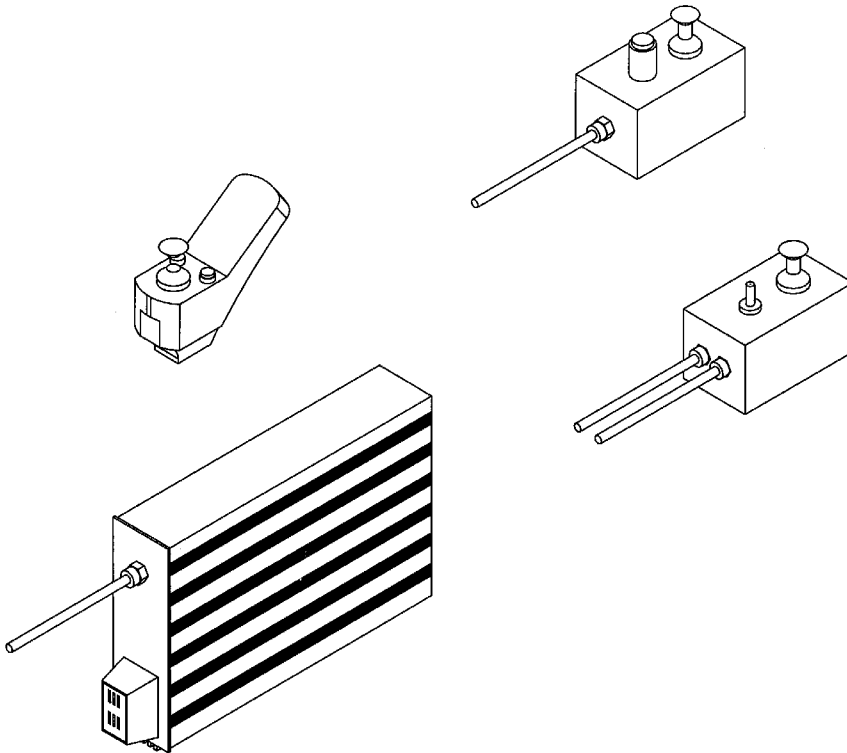

### SERVICE - VARIATIONS

These may be fitted to appropriate mounting brackets using two M.5 x10 pan head screws on items 1, 2 and 3.

Use three M.5x10 pan head screws on item 4 and 2 two M.5x14 countersunk head on item 5.

The nine pin Beau plug and socket of item 5 and the Pilot controller will benefit from a light application of an anti seize fluid or compound. To ensure good electrical contact, prevent corrosion and ease operation when dis-mantling etc.

Check that all plug and socket connections are 100% efficient and that no wires are exposed and showing outside the connector.

Check joystick gaiter for condition, replace if split or damaged.

Refer to instructions on programming and fault diagnosis and ensure that the power chair is safe to use.















---

## BATTERIES AND BATTERY CHARGING

### HOW DOES THE CHARGER WORK?

When the battery voltage is low, the charger works extra hard to bring up the battery charge. As the battery voltage approaches full charge, the charger does not work as hard to complete the charging cycle. This explains why the charging current drops as it approaches a full charge. When the battery is fully charged, the amperage from the charger is near zero, thus (when plugged in) the charger maintains but not overcharges the battery.

### WHERE DO I CHARGE THE BATTERIES?

Later on in this information, there is reference to the way temperature variations can affect the performance of your vehicle, when charging the batteries, where reasonable practicable, ensure that the battery charger is close to the vehicle being charged so that the temperature of the battery charger and batteries are almost compatible.

For example, a vehicle may be outside whilst the battery charger is inside, it is possible in this situation that the battery charger will sense the inside temperature, whereas the batteries on the vehicle will be at the outside temperature, resulting in an overcharged or undercharged situation.

### HOW OFTEN MUST I CHARGE THE BATTERIES?

Many factors come into play when deciding how often to charge the batteries. You may use your vehicle all day on a daily basis or you may not use it for weeks at a time. Other factors such as driver and baggage weight, smooth or rough terrain, flat areas or inclines and speed must all be considered.

With these variables you should concern yourself with two questions; HOW OFTEN should I charge and for HOW LONG?. The charger was so there is no way to overcharge your batteries on a regular basis. If you follow the guidelines below, your batteries will provide safe and reliable operation.

- 1 IF YOU USE YOUR VEHICLE AT ALL WITHIN A DAY:** put it on the charger as soon as you have finished using it. The charger is fully automatic so it will not overcharge your batteries. Your vehicle will be ready each morning to give you a full day's service. It is recommended you charge the batteries for 8-14 hours after daily use.
- 2 IF YOU USE YOUR VEHICLE INFREQUENTLY** (once a week or less): You should charge it at least once per week for 12-14 hours.  
REMEMBER: keep your batteries fully charged and avoid deeply discharging your batteries.
- 3 STRONG BATTERIES:** Batteries should always be stored FULLY CHARGED. Check once a month and recharge fully if needed. Sealed batteries can hold their charge for approx. 6 months. If they are left connected in the chair, remember key switches, meters and accessories can drain the batteries rapidly. It is advisable to disconnect the batteries for prolonged storage.

### HOW CAN I ENSURE THE MAXIMUM BATTERY LIFE?

Simply put, a fully charged battery is a happy battery. A fully charged deep cycle battery will provide reliable performance and extended battery life. So keep your batteries fully charged whenever possible.

**Please be warned,** batteries that are regularly deeply discharged, infrequently charged, or stored without a full charge may be permanently damaged providing unreliable operation and limited life.

## HANDLING BATTERIES

Extra care must be taken when handling batteries, if you decide to dismantle the vehicle for transportation etc. Dropped batteries, even from a very small height, can lead to these plates and plates touching, causing a cell failure.

Do not leave the charger lead connected to the batteries without the mains supply switched on (indicated by only the green LED illuminated on the battery charger). In this condition, the batteries will slowly discharge. Used batteries must not be disposed of by means of a Domestic Refuse Disposal Unit (Dustbin) etc. Please contact your dealer to dispose of used batteries.

## BATTERY WARRANTIES.

The batteries fitted to your vehicle are guaranteed against a manufacturing or material defect for 12 months. Any battery fault due to a defect in manufacture or mis-handling will be obvious within a few weeks of use. The batteries are not guaranteed to perform to full capacity for 12 months. This will, of course, be dependent on the actual use of the vehicle and how often the batteries are cycled, ie discharged and charged.

The gradual deterioration in performance and lack of range is normally associated with fair wear and tear, misuse or accidental damage. Under these circumstances, the warranty will not apply.

## WHY DO MY NEW BATTERIES SEEM WEAK?

Deep cycle batteries employ a much different chemical technology than used in car batteries, nickel cadmium (NI-Cads) or other common battery types. They are specifically designed to provide power, discharge down and then accept a relatively quick recharge.

We work closely with our battery manufacturer to provide a battery that best suits the vehicle's specific demands. Fresh batteries arrive regularly and are promptly delivered with a full charge. During delivery they can encounter temperature extremes that may influence their initial performance. Heat will rob the charge from the battery, cold will slow the power available and extend the time needed to recharge (just like a car battery).

Simply, a brand new battery can often act a little stubborn it might take a few days for the temperature to stabilise and adjust to your room temperature. More importantly, it will take a few 'charging cycles' (a partial drain – then full recharge) to establish the critical chemical balance that is essential to the battery's peak performance and long life.

If you take the time to run-in your battery properly, it will be worth it.

**Remember:** how long your battery will provide service is quite often a reflection of the care it receives. This is how to run-in your new battery:

- 1 Fully recharge any new battery prior to your initial use. This will bring your battery up to about 88% performance.
- 2 Run your vehicle about the house and garden. Do not stray too far until you become accustomed to the controls, the feel of the vehicle and break in the batteries.
- 3 Give the batteries another full charge of 8-14 hours and run the vehicle again. The batteries will now perform over 90% of their potential.
- 4 After four to five charging cycles, the batteries will top off at 100% charge and last for an extended period due to your patience and care in the first few days of operation.

## HOW CAN I GET MAXIMUM RANGE OR DISTANCE PER CHARGE?

Rarely do we have an ideal driving situation such as smooth, flat, hard terrain with on wind or curves. More often, we are presented with hills, paths cracks, uneven and loosely packed surfaces, curves and wind. All these will affect the distance or running time per battery charge.

Here are a few suggestions for obtaining the maximum range per charge:-

- 1 Always charge you batteries fully prior to you trip.
- 2 Maintain relevant type pressures as stated in the Technical Specifications.
- 3 Plan your trip in advance to avoid hills, cracks and broken or soft surfaces.
- 4 Limit your baggage weight to essential items.
- 5 Try to maintain an even speed to avoid stop and go driving.
- 6 Ensure recommended routine servicing of the vehicles components, i.e motors, brakes, electrical connections etc., is carried out.

### 7. Final Drive

- Disengage Mechanism:** With wheels raised from the ground engage and disengage final drive, check for positive re-engagement of lever. Lubricate mechanism.
- Drive Shaft:** Revolve wheel assembly with drive disengaged and check for excessive endfloat and bearing wear. Check hub locating screw is secure.
- Wheel Runout:** Revolve wheels, checking for excessive 'tow in' and excessive side movement of rims. Check for rim damage. Check hub cap security.
- Tyres:** Check tyres for damage and foreign objects. Test pressure (pneumatics) as indicated on the tyre wall. Replace if treadles.  
**CAUTION:** Split rim wheel.

### 8. Kerb Climber

- Operation** Check kerb climber on its mounting on the chair, and cam lock operation. Apply WD40. Operate forward and parked position. Check torsion bush retains tension and rubber feet clear swivelling castors. Replace rubber feet.
- Mounting** Locate the kerb climber to the locating pins, check the spring-loaded latches are locking the kerb climber into position.  
 Apply Molyslip (Copper-Eze) to swivel point (metal casing of torsion bush). Do not apply lubricant to torsion bush rubber.

### 9. Charger

- Mains Plug** Check for any damage to pins or case. Inspect cable and entry into charger. Check fuse rating fitted to plug (5amp). Check fuse ratting at rear of charger.
- Charger Plug** Inspect plug and lead for damage. Check entry into charger. Replace if loose in socket (check for contract discolouration).
- Charging Function:** Connect the charger plug into the charging socket, plug the mains plug into the normally used, mains sockets. Switch mains supply on, and check that the 'mains or light illuminates. The green 'charging' light will come on some



second after this. Because of the length of time involved in the full charging sequence, it is not possible to check the complete charging function.

Ask the owner whether the charger has been completing its charge programme, through to the red 'charge complete' light illuminating.

**10. Test Run**

A short test run should now be carried out to test the driving functions of the chair. If a kerb climber is fitted this also should be tested.

			SERVICE PROGRAMME
DEALER NAME			1. UPHOLSTERY
ADDRESS			BACK SEAT ARMPADS SIDE PANELS SAFETY/CALF STRAP
CUSTOMER (MR/ MRS / MISS)			2. CONTROL MODULES
TEL NO.			ON/OFF DISPLAY OUTPUT WIRING SPEED CONTROL JOYSTICK MOUNTING WARRANTY SEAL
TYPE OF SERVICE – PERIOD			3. CASTORS
DATE OF SERVICE			STEM/BEARING WHEEL BEARINGS FORK & AXLE TYRES-PUNCTURE PROOF
PRODUCT			4. FRAME
SERIAL NO.			FOOT / LEG –RESTS ANIT – TIP WHEELS ARMRESTS / SUPPORTS FOLDING / REC BACK CROSS BRACE
COMMENTS/RECOMMENDATIONS			5. BATTERIES
PARTS REPLACED			BATTERIES/TERMINALS BATTERY BOX BATTERY LEADS MOTOR SOCKETS OUTPUT LEADS
QTY	PART	PART NO	6. MOTORS
COST			MOUNTINGS ARMATURE BRAKES WIRING & CONNECTIONS BRUSHES
			7. FINAL DRIVE
			DISENGAGE MECHANISM FREEWHEEL/DRIVE SHAFT WHEEL RUNOUT RIM TYRES – PNEUMATIC
ENGINEER			8. KERB CLIMBER

PLEASE PRINT	MOUNTLINGS RETURN POSITION RUBBER FEET
ENGINEERS SIGNATURE	9. CHARGER
CUSTOMERS SIGNATURE	MAINS PLUG CHARGER PLUG CHARGING FUNCTION
DATE	10. FUNCTION RUN
FOR OFFICE USE	TEST RUN
DATE	
PARTS COST	
APPROVED	SERVICE TIME 120'

## BATTERY BOX ASSEMBLY - REAR

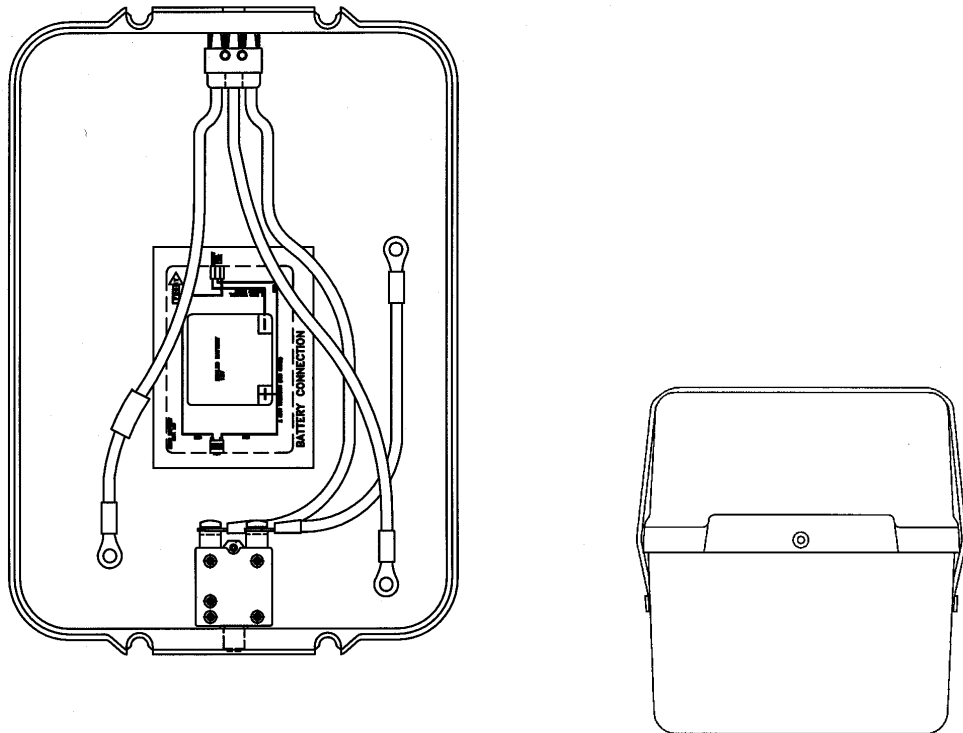

### BATTERIES - LID ACEMENT

It is advisable to obtain the battery box lid assembly factory wired for safety and reliability.

The following instructions apply if this is not practical.

It is of the utmost importance to pay attention to ensuring all connections are tightened correctly.

- 1 Remove battery box assembly from the chair following instructions in the User Manual.
- 2 Release the lid retaining screws, both sides, open lid sufficiently to gain easy access.
- 3 Dis-connect battery terminals, taking note of wire connections. It is advisable to tie the wire together to ensure correct re-assembly.

**DO NOT ALLOW TOOLS OR CABLES TO SHORT OUT ACROSS BATTERY TERMINALS (RESULT - BOOM! - CARDIAC ARREST)**

- 4 Reconnect replacement batteries in the reverse order, ensuring the correct cables are fitted to the correct terminals and fully tightened. Refer to the circuit diagram if in doubt. Lightly grease all terminals with petroleum jelly (Vaseline).
- 5 Wiring loom assembly can be replaced as a spare part, remove two x m.3 screws and nuts. Ensure the reinforcing plate and washers are in place, tighten sufficiently to achieve a good connection. Do not tighten so as to affect the battery box moulding.
- 6 Check the condition of the circuit breaker (d), ensuring the button locks positively. Check terminal connections are tight and in good condition.  
Replace only with identical value i.e. 40 amp etc.

**NOTE:** Do not use Loctite thread locking compounds (or similar) as under certain circumstance, they may affect the ABS box and lid causing cracking.

**MOTOR SOCKET CONNECTIONS****RIGHGT HAND**

PIN 1 PIN 2	BROWN	+POSTIVE MOTOR SUPPLY LINKED TO PIN 1
PIN 3	RED	(SMALL) SOLENOID BRAKE
PIN 4 PIN 5	BLUE	-NEGATIVE MOTOR BRAKE LINKED TO PIN 4
PIN 6	BLACK	(SMALL) SOLENOID BRAKE

**LEFT HAND**

PIN 1 PIN 2	YELLOW	-NEGATIVE MOTOR SUPPLY LINKED TO PIN 1
PIN 3	RED	(SMALL) SOLENOID BRAKE
PIN 4 PIN 5	GREEN	+ POSITIVE MOTOR SUPPLY LINKED TO PIN 4
PIN 6	BLACK	(SMALL) SOLENOID BRAKE

**BEAU SOCKET CONNECTIONS**

CONNECTORS	WIRE COLOUR	CONNECTED TO
PIN 1	YELLOW	-NEGITIVE RIGHT HAND MOTOR
PIN 2	GREEN	+POSTIVE RIGHT HAND MOTOR
PIN 3	BROWN	-NEGITIVE LEF HAND MOTOR
PIN 4	BLUE	+ POSITIVE LEFT HAND MOTOR
PIN 5 PIN 6	RED (LARGE)	+ POSITIVE FROM BATTERY * LINKED TO PIN 5
PIN 7 PIN 8	BLACK	- NEGATIVE FROM BATTERY # LINKED TO PIN 7
PIN 9	RED (SMALL)	+ POSTIVE TO BRAKES

**PLUG & SOCKET CONNECTIONS  
MOTOR AND MAIN CONTORL LOOM**





## MOTORS

### CARBON BRUSH - REPLACEMENT

- 1 Replace carbon brushes as a pair to both motor when they are worn down to 8mm or less in length.
- 2 Remove retaining caps (a) withdraw used brush from retainer, inspect motor commutator for condition, clear out carbon residue.
- 3 Fit new brush into retainer, pushing spring down, fit retaining cap and tighten. Ensure cap thread is not crossed and correctly seated.
- 4 Run the motor for a short period approx. 20 minutes, to bed in brushed.

### SOLENOID BRAKE - REPLACEMENT

- 1 Remove the screws (b0 securing the brake cover ©.
- 2 Remove the two socket head screw and spring washers retaining the solenoid brake to the motor and plate.
- 3 Loosen the small socket grub screw (d) retaining the drive dog into the end of the commutator shaft and gently prise off.
- 4 Cut brake feed wires routed from the Motor Plug lead.
- 5 Fit replacement brake unit in reverse order. When refitting the drive dog into the shaft, push it down completely then pull it back up the shaft approximately 2m to allow clearance when the drive dog spins at motor speed.
- 6 Use the remaining brake leads to pull the feed wires through the sleeving to the motor plug.
- 7 Re-solder to existing connections ensuring a good joint. The wires are not polarized and can be connected to either contact.
- 8 If alternate method is more practical, strip back insulation from wires routed from the motor plug lead. Shorten leads from brake unit 5cm, strip back insulation, twist together each wire. Ensure a good solder connection and using silicone Rubber sleeving (heat resist) cover exposed connection to ensure adequate insulation from motor body.  
**DO NOT TWIST WIRES TOGETHER AND APPLY INSULATION TAPE. A good solder connection is important.**
- 9 Test for function (is any excessive heat being generated?) Replace brake cover.



## MOTORS

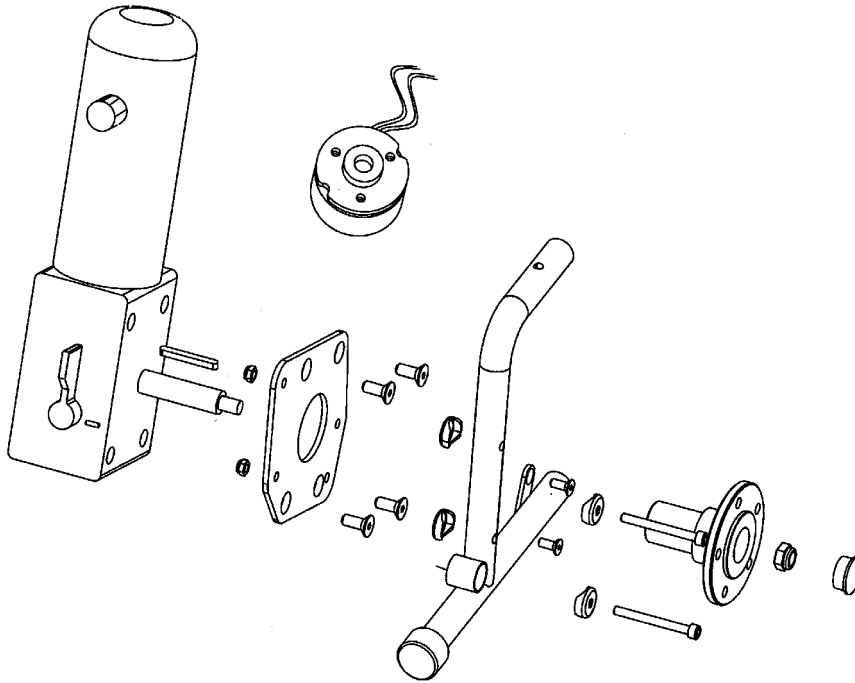

### MOTOR REPLACEMENT

The motor supplied as a spare part will come complete with drive shaft key (a) and hub nut (g). Motor mounting plate (b) is a handed item.

#### Removal : Disconnect motor plug at battery box unit

- 1 Remove wheel assembly, following the applied instructions carefully.
- 2 Prise of end cap (if fitted) and release hub nut (g). Pull off wheel hub. Wheel assembly attached the hub can be removed complete if required.
- 3 Loosen and release the two M.6 x 10 lower mounting countersunk socket and head screws (e).
- 4 Holding the weight of the motor loosen and release the two M.6x4 mounting socket head bolts (f). Note position of the saddle washers (d).
- 5 Remove the four M.8x 16 screws © retaining the mounting plate to the motor gearbox. These screws have been fitted with Loctite 222 and may require additional pressure to release them.

Re-fit replacement motor in reverse order to above. Apply a small quantity of Loctite 222 to the motor mounting plate screws ©, Ensure all fixings are tight and secure. It is recommended that the new replacement drive shaft key and hub nut are fitted. Plug in motor plug, ensure retaining clips is functional and test for correct operation.

Run the Motor for a short period, approximately 20 minutes to clear manufacturers residue and bed in carbon brushes.

## SOLENOID BRAKE TEST

- 1 Check that the chair cannot be pushed by hand with the controller switched off, i.e no power to the motors.
- 2 Check each brake connection for good contact at motor plug and socket assembly.
- 3 Check each brake's resistance using an ohm-meter across the connection contacts (Pin 3 & 6 ), with the motor plug disconnected from the motor socket at the battery box.  
  
The resistance reading is between 58R and 60R at room temperature.  
  
The solenoid brake test applies to both units fitted to either the EMD motor or the Fracmo motor.
- 4 Remove motor brake cap cover, take care to feed supply wires through grommet hole, without staining cables.
- 5 Remove two screws holding the brake to the motor.
- 6 Ease the brake from the commutator shaft.
- 7 Test the brakes for freedom of movement, listen for clicking noise each time the joystick is moved from the central position.
- 8 Check that the brake disc can be moved when the joystick is activated (with power on) and the disc becomes tight when the joystick is released (returned to the central position). If the brake fails this test, replace it.

## **ASSESSMENT OF BATTERIES USED IN CYCLE APPLICATIONS**

### **Introduction**

A great number of rechargeable lead acid batteries are used in applications where they are routinely discharged and recharged. This type of battery usage is known as cyclic use and is typified by such applications as powered golf trolleys and electric wheelchairs etc. Where a user perceives a reduced performance from the application then it is necessary to determine the reasons for the reduction and, where this is found to be the battery, to assess feasibility of a possible warranty claim. This document has been prepared to help manufacturers and distributors with the process of assessment of the battery condition.

### **1. Is the battery defective?**

Poor performance may be due to the equipment the battery, the battery charger or abusive use and it is necessary to determine which of these is the cause of the problem. Bear in mind also that a combination of contributory factors may exist. In the absence of special test equipment it may be possible to eliminate some factors by substitution, as an example, a user of an electric golf caddy experiencing poor performance could consider asking another user to test a support battery with equipment and in this way the caddy itself could be eliminated or confirmed defective. A similar method can be used to check the charging equipment.

### **2. Physical Inspection of batteries.**

A battery being considered for possible reduced performance should be inspected for physical damage, which could lead to rejection of the claim. Points to consider are as follows:

- a) Damaged cases – any cracking of the casing, which allows air into the battery will cause premature failure. Such damage is not readily obvious with batteries having non-spillable electrolyte and damage could be present on the under surface of cases.
- b) Bulging of battery cases – this is usually a sign of overcharging and will be present on all cells if bulged, then this could be a defect.
- c) Concave battery cases – this is usually a sign that the battery has been overcharged at a relatively high temperature. On cooling, the valves of the battery will not allow pressure to equalise and “sucking in” of the casing may result.

### **3. Battery charging**

A battery, which has been incorrectly charged, will not be considered for warranty purpose & for this reason; the charging regime integrity should be established. The battery requirements in terms of charging voltage and current are specified in the manufacturer's brochures and these requirements will have been considered by the equipment manufacturer. It follows that use of other than specified charging equipment will invalidate warranty claims.

Periodic checking of charging equipment by the equipment supplier is recommended.

It should be noted that with many chargers, the indication of “charge complete” should not be taken as an instruction to terminate the charging process. In most cases this indication means that the bulk of the charge has been completed but the battery should be left to complete the final few percentage points of recharging. With chargers that feature a “float” charge facility, it is recommended that batteries are left connected to the energised charger until next needed.

### **4. Guarantee Period**

The guarantee offered by most battery suppliers covers failures caused by manufacturing defects within a specified period of time. The terms of the guarantee do not cover battery premature failures due to high usage rates or misuse. It is essential to check that the guarantee period has not expired. Sonnenschein batteries are guaranteed for 12 months from date of purchase.

## **5. Cyclic Life Expectancy of Batteries**

The number of times that a battery can be charged a discharged before its capacity drops to a specific level is known as its cyclic life. Cyclic life specifications for batteries are quoted for standard laboratory conditions. The actual service life of a battery will depend on many factors such as depth of discharge, temperature, charging conditions etc, etc. Battery warranty claims, which are found to be a result of cyclic life exhaustion, will not be accepted.

## **6. Cyclic Life Factors.**

The most significant factor affecting cyclic life in service is the depth of discharge experienced by the battery.

The normal limits to battery discharge depth are quoted in the manufacturer's product.

It is important not to exceed these limits if the best cyclic lifetime is to be achieved. To this end it is unwise to allow a battery to continue to discharge when it show signs of being "flat" Deep discharge of batteries can result from continuing with a discharge after a period of rest, when that battery has apparently recovered, or using equipment, such as an electric gold trolley, as a "crutch" to assist its user up a slope for instance. In hot temperature conditions, a battery will be capable of providing significantly more duration time than normal. If the battery is allowed to deliver this extra energy, then it will driven into deep discharge with consequent cyclic life reduction.

Batteries are often forced into extremely deep discharge by leaving them connected to electrical consumer circuits when they have been normally discharged. Typically the circuits may be indicators or control circuits taking a very small current of a few milliamps. Under these conditions it is not unusual for a battery to delivery more than 150% of its rated capacity, with consequent deep discharge penalty.

Other good examples of over discharging are trying to achieve too many holes or rounds of golf in a day, or allowing too few hours for recharging between uses.

## **7. Pre-test check**

When assessing batteries returned under guarantee claim by user, the supplier should carry out checks on each battery before conducting performance test. The physical checks described in 2, should be made and also it should be confirmed that the battery was actually supplied by the organisation i.e. proof of purchase should be established. Purchase date should be within the period of guarantee.

## **8. Voltage tests**

The open circuit voltage of each battery should be measured using a DC voltmeter of at least 10,000 ohms per volt sensitivity.

Batteries having a voltage of less than 1.65 volts per cell (9.9 v for a 12V battery of 4.95 V for a 6V battery) should be rejected as being deeply discharged.

Batteries having more than 2.25. volts per cell ( 13.5V for a 12V battery or 6.75V for a 6V battery) may well have overcharged, particularly if case bulging is also apparent-these batteries should also be rejected.

## **9. Discharge test**

Before carrying out discharge performance tests, the batteries must be fully charged to ensure full charge state. Overnight charging is recommended.

The nature of the discharge test will depend on what test equipment is available. Equipment may consist of simple improvised loads such as lamps and resistors or more sophisticated equipment having constant current or constant power discharge capability.

By reference to the product brochures it may be ascertained how long a specific battery will support a particular load level until a designated voltage level is reached. The actual achieved test duration time can be divided by the specification duration time to establish the available capacity as proportion of its specified capacity at the particular discharge rate.

It should be noted that the actual capacity achieved on test will only be comparable with nominal battery capacity if the discharge rate is the same as the nominal rate. This means that a battery having a nominal capacity of 25 Ah at the C<sub>20</sub> rate will only give a 30 Ah if discharged over 100 hours or some 15 Ah if discharged at 1 hour rate. This means that the manufacturer's discharge table must be used for evaluating tests.

### **10. Interpretation of test results.**

The rest obtained for each battery may be expressed as a percentage of the specified duration. When valuating the results is necessary to consider what performance level constitute an acceptable performance. It is important to differentiate between acceptable performances based on normal battery again factors and what is expected by the specific users application.

To illustrate this point, consider an electric gold cart application, which is particularly demanding. (A very hilly course for instance). It may well be the case that almost 100% of the battery capacity is needed for a typical gold round. As the battery ages, its capacity will gradually reduce and the user may well experience problems when the battery still has 95% of its nominal capacity available.

This illustration describes an application where a larger battery would be a better solution.











---

***INVACARE® INTERNATIONAL:***

***Belgium & Luxemburg:*** Autobaan 14 · B-8210 Loppem

***Danmark:*** Sdr. Ringvej 39 · DK-2605 Brøndby

***Deutschland, Österreich, Switzerland & East Europe:*** Dehmer Straße 66 · D-32549 Bad Oeynhausen

***España:*** c/ Areny · s/n Polígon Industrial de Celrà · E-17460 Celrà (Girona)

***France:*** Les Roches · F-37230 Fondettes

***Italia:*** Via dei Pini 62 · I-36016 Thiene (VI)

***Nederland:*** Celsiusstraat 46 · NL-6716 BZ Ede

***Norge:*** Grensesvingen 9 · N-0603 Oslo

***Portugal:*** Rua Senhora de Campanhã 105 · P-4369-001 Porto

***Sverige & Suomi:*** Fagerstagatan 9 · P.O. Box 66 · S-163 91 Spånga

***United Kingdom & Eire:*** South Road · Bridgend Industrial Estate · Bridgend CF31 3PY · UK

