

Invacare[®] FDX[®] Series
SERVICE MANUAL



Edition: 1541504 Vers. 008 - 22.10.2014



These instructions contain information about:

Testing work

Repair Instructions

This manual is part of the instructions for use.

Service addresses

A	Invacare Austria GmbH	(:	+43 6232 5 53 50
	Herzog Odilostrasse 101	Fax:	+43 6232 5 53 54
	A-5310 Mondsee	@:	info@invacare-austria.com
	Austria	WWW:	www.invacare.at

B	Invacare n.v.	(:	+32 (0)50 83 10 10
	Autobaan 22	Fax:	+32 (0)50 83 10 11
L	B-8210 Loppem (Brugge)	@:	belgium@invacare.com
	Belgium	WWW:	www.invacare.be

CH	Invacare AG	(:	+41 (0)61487 70 80
	Benkenstraße 260	Fax:	+41 (0)61487 70 81
	CH-4108 Witterswil	@:	switzerland@invacare.com
	Switzerland	WWW:	www.invacare.ch

D	Invacare Aquatec GmbH	(:	+49 (0)7562 70 00
	Alemannenstraße 10	Fax:	+49 (0)7562 7 00 66
	88316 Isny	@:	info@invacare-aquatec.com
	Deutschland	WWW:	www.invacare-aquatec.de

DK	Invacare A/S	((Kundeservice):	+45 (0)36 90 00 00
	Sdr. Ringvej 37	Fax (Kundeservice):	+45 (0)36 90 00 01
	DK-2605 Brøndby	@:	denmark@invacare.com
	Danmark	WWW:	www.invacare.dk

E	Invacare® SA	(:	+34 (0)972 49 32 00
	c/ Areny s/n	Fax:	+34 (0)972 49 32 20
	Polígon Industrial de Celrà	@:	contactsp@invacare.com
	E-17460 Celrà (Girona)	WWW:	www.invacare.es
ESPAÑA			

F	Invacare® Poirier SAS	(:	+33 (0)247 62 64 66
	Route de St Roch	Fax:	+33 (0)247 42 12 24
	F-37230 Fondettes	@:	contactfr@invacare.com
	France	WWW:	www.invacare.fr

GB	Invacare® Ltd	((Customer services):	+44 (0)1656 77 62 22
	Pencoed Technology Park	Fax (Customer services):	+44 (0)1656 77 62 20
	Pencoed	@:	uk@invacare.com
	Bridgend CF35 5HZ	WWW:	www.invacare.co.uk
United Kingdom			

I	Invacare Mecc San s.r.l.	(:	+39 0445 38 00 59
	Via dei Pini, 62	Fax:	+39 0445 38 00 34
	I - 36016 Thiene (VI)	@:	italia@invacare.com
	Italia	WWW:	www.invacare.it

IE	Invacare Ireland Ltd. Unit 5 Seatown Business Campus Seatown Rd, Swords County Dublin Ireland	(: Fax: @: WWW:	+353 18 10 70 84 +353 18 10 70 85 ireland@invacare.com www.invacare.ie
N	Invacare® AS Grensesvingen 9 Postboks 6230 Etterstad N-0603 Oslo Norge	((Kundeservice): Fax (Kundeservice): @: @: WWW:	+47 (0)22 57 95 00 +47 (0)22 57 95 01 norway@invacare.com island@invacare.com www.invacare.no
NL	Invacare® B.V. Celsiusstraat 46 NL-6716 BZ Ede Nederland	(: Fax: @: @: WWW:	+31 (0)318 69 57 57 +31 (0)318 69 57 58 nederland@invacare.com csede@invacare.com www.invacare.nl
P	Invacare Lda Rua Estrada Velha, 949 P-4465-784 Leça do Balio Portugal	(: (: Fax: @: WWW:	+351 225 10 59 46 +351 225 10 59 47 +351 225 10 57 39 portugal@invacare.com www.invacare.pt
S	Återförsäljare: Invacare® AB	((Kundtjänst): Fax (Kundtjänst):	+46 (0)8 761 70 90 +46 (0)8 761 81 08
FIN	Fagerstagatan 9 S-163 91 Spånga Sverige	@: @: WWW:	sweden@invacare.com finland@invacare.com www.invacare.se
	Tillverkare: Invacare® Deutschland GmbH Kleiststraße 49 D-32457 Porta Westfalica Deutschland	MÖLNDAL (: Fax: @:	+46 (0)31 86 36 00 +46 (0)31 86 36 06 ginvacare@invacare.com
		LANDSKRONA (: Fax: @:	+46 (0)418 2 85 40 +46 (0)418 1 80 89 linvacare@invacare.com
		OSKARSHAMN (: Fax: @:	+46 (0)491 1 01 40 +46 (0)491 1 01 80 oinvacare@invacare.com
Eastern european countries	European Distributor Organisation (EDO) Kleiststraße 49 D-32457 Porta Westfalica Deutschland	(Fax @: WWW:	+49 (0)5731 75 45 40 +49 (0)5731 75 45 41 edo@invacare.com www.invacare.de

Table of contents

Chapter		Page
1	INTRODUCTION	8
1.1	General information	8
1.2	Notes on transport	8
1.3	Definition and representation of information and safety information in this manual	9
1.4	Hazard symbols and symbols used	10
1.5	Images in this manual	11
2	SAFETY AND FITTING INSTRUCTIONS	12
2.1	Before any inspection or repair work	12
2.2	Personal safety equipment	12
2.3	General safety information and information about fitting / removal	12
3	TIGHTENING TORQUES	14
4	ARRANGEMENT OF SUB-ASSEMBLIES AND COMPONENTS	15
4.1	Overview	15
4.2	Electronic modules	16
4.2.1	ACS2 PMB70 / ACS2 PMB70L electronic module	17
4.2.2	ACS2 PMA90L electronic module	17
4.2.3	Actuator module ACT	17
4.2.3.1	Actuator module ACT2	17
4.2.3.2	Actuator module ACT 4	18
4.2.4	Lighting circuit board	18
4.3	Remotes	19
5	MAINTENANCE PLAN (ONCE A YEAR)	21
6	OPERATIONAL FAULTS	24
6.1	Drive fault diagnosis	25
6.2	REM remotes: Error codes and diagnostic codes	29
6.3	Diagnosis of charging device faults	31

7	TEST PROCEDURES	32
7.1	Testing the motor	32
7.2	Testing the electro-mechanical parking brake	33
8	REPAIR WORK	35
8.1	Covers	35
8.1.1	Open front cover	35
8.1.2	Opening the rear cover	36
8.1.3	Opening the lateral cover	37
8.1.4	Opening the cover of the rear wheel cantilever arm	40
8.2	Electronic modules	41
8.2.1	Replacing remotes	41
8.2.2	Replacing electronic modules	41
8.2.3	Replacing the G-Trac sensor	44
8.2.4	Drive program selection after component replacement	46
8.2.4.1	Profile selection with G90A remote	46
8.2.4.2	Profile selection with remote REM A or REM B	47
8.2.4.3	Profile selection with remote REM 550	48
8.3	Updating the driving program	49
8.4	Batteries, cables & battery chargers	50
8.4.1	Removing the batteries	50
8.4.2	Replacing batteries / replacing battery cables	53
8.4.3	How to handle damaged batteries correctly	55
8.4.4	Replacing the main fuse	55
8.4.5	Checking the cables	56
8.5	Replacing the battery boxes	58
8.6	Lighting system	59
8.6.1	Replacing light bulbs in the front (conventional lighting system)	59
8.6.2	Replacing the LEDs in the front (LED lighting system)	59
8.6.3	Replacing the complete head lamp assembly (conventional lighting system until 03/2012)	60
8.6.4	Replacing headlamps completely (conventional lighting system starting 03/2012)	62
8.6.5	Replacing the head lamps completely (LED lighting system until 03/2012)	64
8.6.6	Replacing headlamps completely (LED lighting system starting 03/2012)	66
8.6.7	Replacing the head lamp bracket (conventional lighting system until 03/2012)	68
8.6.8	Replacing headlamp brackets (conventional lighting system starting 03/2012)	69
8.6.9	Replacing the front bulb holder (LED lighting system until 03/2012)	70
8.6.10	Replacing a light bulb in the rear (conventional lighting system)	71
8.6.11	Replacing the LEDs in the rear (LED lighting system)	71
8.6.12	Replacing the complete tail lamp assembly (conventional lighting system until 08/2014)	72
8.6.13	Replacing the complete tail lamp assembly (conventional lighting system starting 08/2014)	74
8.6.14	Replacing the tail lamp bracket (conventional lighting system until 08/2014)	76
8.6.15	Replacing the tail lamp bracket (conventional lighting system starting 08/2014)	77
8.6.16	Replacing the tail lamps completely (LED lighting system)	78
8.7	Rear wheels	79
8.7.1	Replacing a rear wheel	79
8.7.2	Replacing a rear wheel fork	80
8.7.3	Adjusting the wheel fork	82
8.8	Drive wheels	84

8.8.1	Replacing a drive wheel	84
8.8.2	Replacing a tyre	85
8.8.3	Replacing a drive wheel hub	86
8.9	Replacing the spring in the rear	88
8.10	Replacing the anti-tipper wheels	90
8.11	Drive unit	91
8.11.1	Replacing the motor / gearbox unit	91
8.11.2	Replacing or rotating the motor / gearbox unit sealing ring	93
8.11.3	Replacing the motor / gearbox coupling	94
8.11.4	Replacing the carbon brushes	96
8.11.5	Fitting the clutch rotary knob (SSD motor)	98
8.11.6	Running the motor in	99
8.12	Replacing the motor / gearbox fixation and rear wheel cantilever arm	100
8.13	Seat adjustment standard	102
8.13.1	Seat / seat frame (without lifter)	102
8.13.2	Replacing the tilt module / lifter module	105
8.13.2.1	Replacing the tilt module (without lifter)	105
8.13.2.2	Replacing the lifter / tilt module	108
8.13.2.3	Replacing the tilt actuator	112
8.13.2.4	Replacing the lifter actuator	114
8.13.3	Seat frame	120
8.13.3.1	Adjusting the seat width	120
8.13.3.2	Adjusting the seat depth	122
8.14	Centre-mounted legrest (electric & manual)	126
8.14.1	Replacing the manually operated centre-mounted legrest	126
8.14.2	Replacing the electrically operated centre-mounted legrest	127
8.14.3	Replacing the electrically operated centre-mounted legrest LNX (Modulite seat)	129
8.14.4	Replacing an electric legrest actuator	130
8.14.5	Replacing the calf plate on the centre-mounted legrest (electric & manual)	132
8.14.6	Replacing the foot plate on the centre-mounted legrest (electric & manual)	133
8.15	Back unit	134
8.15.1	Replacing the standard back	134
8.15.2	Adjusting the belt back	135
8.15.3	Replacing the EasyAdapt back	136
8.15.4	Replacing / adjusting the universal backrest frame for the EasyAdapt backrest	137
8.16	Back unit with ergonomic length adjustment	140
8.16.1	Adjusting the width	140
8.16.2	Replacing the planetary gear	141
8.16.3	Replacing the servo motor	143
8.16.4	Replacing the microswitch	144
8.16.5	Fitting back plates to the base support of the back with ergonomic length adjustment	145
8.16.6	Fitting the handlebar	146
8.16.7	Replacing the travelling armrest	147
8.16.8	Replacing the arm support on the travelling armrest	148
8.16.9	Retrofitting a travelling armrest	149
8.17	Seat adjustment Modulite	150

8.17.1	Seat / seat frame Modulite (without lifter)	150
8.17.2	Replacing the tilt actuator	153
8.17.3	Replacing the lifter actuator	154
8.17.4	Replacing the lifter / seat angle adjustment module	155
8.17.5	Replacing the backrest actuator	158
8.18	Backrest Modulite	159
8.18.1	Replacing the standard backrest	159
8.18.2	Replacing the backrest mounting bracket	160
8.18.3	Replacing the backrest mounting bracket for SB 53	161
8.18.4	Adjusting the seat width/ backrest width	162
8.18.4.1	Adjusting the seat width	162
8.18.4.2	Adjusting the seat width (legrest LNX)	164
8.18.4.3	Adjusting the backrest width	166
8.18.4.4	Adjusting the Flex3 backrest	168
8.19	Fixation rings	169
8.19.1	Replacing a front fixation ring	169
8.19.2	Replacing a rear fixation ring	170
9	INSTALLING ACCESSORIES	171
9.1	Replacing the restraining belt	171
9.2	Replacing the harness belt	172
9.3	Replacing seat belts (Modulite seat)	174
9.3.1	Installation on the backrest mounting bracket (simple backrest)	174
9.3.2	Installation on the backrest mounting bracket (adjustable seat)	175
9.3.3	Installation on the seat frame profile (adjustable seat)	176
9.3.4	Replacing the harness belt (adjustable seat)	177
9.3.5	Replacing the harness belt (simple seat)	179
9.4	DAHL Docking Station	181
9.5	Fitting the stick holder	184
9.6	Further accessories	185

1 Introduction

1.1 General information

- Service and maintenance work must be carried out taking this service manual into account.
- It is imperative that you observe safety information.
- Information about operation or about general maintenance and care work on the mobility aid should be taken from the operating manual.
- You can find information about ordering spare parts in the spare parts catalogue.
- Only use original Invacare® spare parts. The guarantee will become invalid if other spare parts are used!
- We reserve the right to make any alterations on the grounds of technical improvements.
- The mobility aid may only be maintained and overhauled by qualified personnel.
- The minimum requirement for service technicians is suitable training, such as in the cycle or orthopaedic mechanics fields, or sufficiently long-term job experience.
 - Experience in the use of electrical measuring equipment (multimeters) is also a requirement.
 - Special Invacare® training is recommended.
- Alterations to the mobility aid which occur as a result of incorrectly or improperly executed maintenance or overhaul work lead to the exclusion of all liability on the side of INVACARE.
- If you have any problems or questions please contact Invacare® Service.

1.2 Notes on transport

- If the mobility aid has to be shipped back to the manufacturer for major repairs, you should always use the original packaging for transport.
- Please attach a precise description of the fault.

1.3 Definition and representation of information and safety information in this manual

Different types of information and signal words are used throughout this manual.



HAZARD!

The signal word "HAZARD!" refers to immediate hazards.

- *The following lines in italics refer to actions which serve to avoid such hazards.*
-



WARNING!

The signal word "WARNING!" refers to possibly-occurring hazards which can lead to death or serious injuries if they are not avoided.

- *The following lines in italics refer to actions which serve to avoid such hazards.*
-



ATTENTION!

The signal word "ATTENTION!" refers to possibly-occurring hazards which can lead to minor injuries and/or material damage if they are not avoided.

- *The following lines in italics refer to actions which serve to avoid such hazards.*
-



CAUTION!

The signal word "CAUTION!" refers to hazards which could lead to material damage if they are not avoided.

- *The following lines in italics refer to actions which serve to avoid such hazards.*
-



Note

The signal word "Note" is used to denote general information which simplifies the handling of your product and refers to special functions.

1.4 Hazard symbols and symbols used

Different types of hazard symbols and symbols are used throughout this manual.



General hazards

This symbol warns you of general hazards!

- Always follow the instructions to avoid injury to the user or damage to the product!



BURN HAZARD!

This symbol warns you of the danger of chemical burns, for example due to the discharge of battery acids!

- Always follow the instructions to avoid injury to the user or damage to the product!



DANGER OF CRUSHING!

This symbol warns you of crushing hazards due to inattentive working with heavy components.

- Always follow the instructions to avoid injury to the user or damage to the product!



EXPLOSION HAZARD!

This symbol warns you of an explosion hazard, which can be caused by excessive tyre pressure in a pneumatic tyre.

- Always follow the instructions to avoid injury to the user or damage to the product!



Wear safety shoes

The symbol refers to the requirement for wearing safety shoes.

- Wear standardised safety shoes during all work.



Wear eye protection

This symbol refers to the requirement for wearing eye protection, for example when working with batteries.

- Wear eye protection when this symbol is shown.



Wear safety gloves

This symbol refers to the requirement for wearing safety gloves, for example when working with batteries.

- Wear safety gloves when this symbol is shown.



Note

This symbol identifies general information which is intended to simplify working with your product and which refers to special functions.



Requirements:

- This symbol identifies a list of various tools, components and items which you will need in order to carry out certain work. Please do not attempt to carry out the work if you do not have the listed tools available.



Always dispose used or damaged batteries correctly

The symbol refers to information for the correct disposal of used or damaged batteries.

1.5 Images in this manual

The detailed images in this manual are given digits to identify various components. Component numbers in text and operational instructions always relate to the image directly above.

2 Safety and fitting instructions

These safety instructions are intended to prevent accidents at work, and it is imperative that they are observed.

2.1 Before any inspection or repair work

- Read and observe this repair manual and the associated operating manual!
- Observe the minimum requirements for carrying out the work (see chapter entitled „General information“)

2.2 Personal safety equipment



Safety shoes

The mobility device, and some of its components, are very heavy. These parts can result in injuries to the feet if they are allowed to drop.

- *Wear standardised safety shoes during all work.*



Eye protection

It is possible that battery acid can be discharged when working on defective batteries or when handling batteries improperly.

- *Always wear eye protection when working on any defective or possibly defective batteries.*



Safety gloves

It is possible that battery acid can be discharged when working on defective batteries or when handling batteries improperly.

- *Always wear acid-proof safety gloves when working on any defective or possibly defective batteries.*

2.3 General safety information and information about fitting / removal



WARNING: Danger of crushing!

Various components such as the drive unit, batteries, seat etc are very heavy. This results in injury hazards to your hands!

- *Please note the high weight of some components! This applies especially to the removal of drive units, batteries and the seat.*



WARNING!

Injury hazard if the vehicle starts moving unintentionally during repair work!

- *Switch the power supply off (ON/OFF key)!*
- *Engage the drive!*
- *Before raising the vehicle, secure the wheels by blocking them with wedges!*



ATTENTION!

Fire and burn hazard due to electrical short-circuit!

- *The mobility device must be completely switched off before removal of voltage-carrying components! To do this, remove the batteries.*
- *Avoid short-circuiting the contacts when carrying out measurements on voltage-carrying components!*

**CAUTION!****Danger of burns from hot surfaces on the motor!**

- *Allow the motors to cool down before commencing work on them.*

**ATTENTION!****Injury hazard and danger of damage to vehicle due to improper or incomplete maintenance work!**

- *Use only undamaged tools in good condition.*
- *Some moving parts are mounted in sockets with PTFE coating (Teflon™). Never grease these sockets!*
- *Never use "normal" nuts instead of self-locking nuts.*
- *Always use correctly-dimensioned washers and spacers*
- *When reassembling, always replace any cable ties which were cut during dismantling.*
- *After completing your work / before renewed start-up of the mobility device, check all connections for tight fitting.*
- *After completing your work / before renewed start-up of the mobility device, check all parts for correct locking.*
- *Only operate the vehicle with the approved tyre pressures (see technical data).*
- *Check all electrical components for correct function. Please note that incorrect polarity can result in damage to the electronic.*
- *Always carry out a trial run at the end of your work.*

**CAUTION!****Danger of injury and damage to property, if the maximum speed reduction on a wheelchair with a lifter does not function correctly!**

The wheelchair's control unit must reduce the maximum possible speed as soon as the lifter is raised.

- *Test the maximum speed reduction for correct function after any maintenance work or modifications to the wheelchair.*

**Note**

Mark all current settings for the mobility aid (seat, armrests, backrest etc.), and the associated cable connecting plugs, before dismantling. This makes reassembly easier. All plugs are fitted with mechanical safety devices which prevent release of the connecting plugs during operation. To release the connecting plugs the safety devices must be pressed in. When reassembling ensure that these safety devices are correctly engaged.

**WARNING!****Any changes to the drive program can affect the driving characteristics and the tipping stability of the vehicle!**

- *Changes to the drive program may only be carried out by trained Invacare® specialist dealers!*
- *Invacare® supplies all mobility aids with a standard drive program ex-works. Invacare® can only give a warranty for safe vehicle driving behaviour - especially tipping stability - for this standard drive program!*

3 Tightening torques

The tightening torques stated in the following list are based on the thread diameter for the nuts and bolts for which no specific values have been determined. All values assume dry and de-greased threads.

Thread	M4	M5	M6	M8	M10	M12	M14	M16
Tightening torque in Nm $\pm 10\%$	3 Nm	6 Nm	10 Nm	25 Nm	49 Nm	80 Nm	120 Nm	180 Nm

**CAUTION!**

Damage can be caused to the mobility device due to improperly tightened screws, nuts or plastic connections.

- Always tighten screws, nuts etc to the stated tightening torque.
- Only tighten screws or nuts which are not listed here fingertight.

4 Arrangement of sub-assemblies and components

4.1 Overview

In the rear under the seat:

Electronic modules

The electronic modules are located under the rear cover:

- (1) – Electronic module
- (2) – Actuator module (optional)
- (3) – Lighting circuit board (optional & not shown in the illustration)

The electronic modules that are installed are described in chapter 4.2.

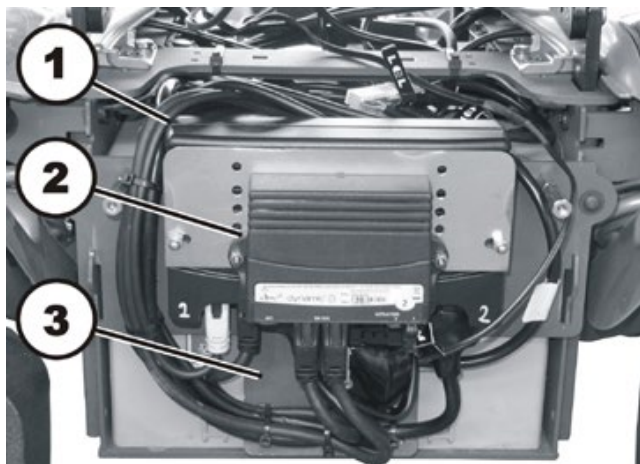

In the front under the seat:

- (1) – Actuator module (optional)
- (2) – Lifter actuator (optional)
- (3) – Tilt actuator (optional)

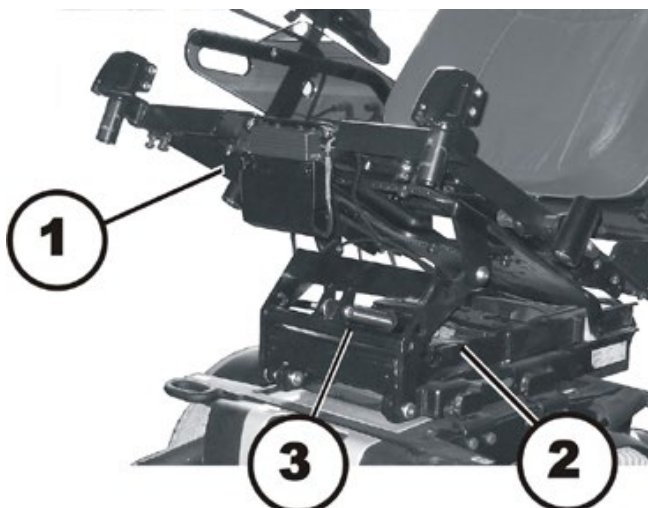

On the right, next to the spring seat:

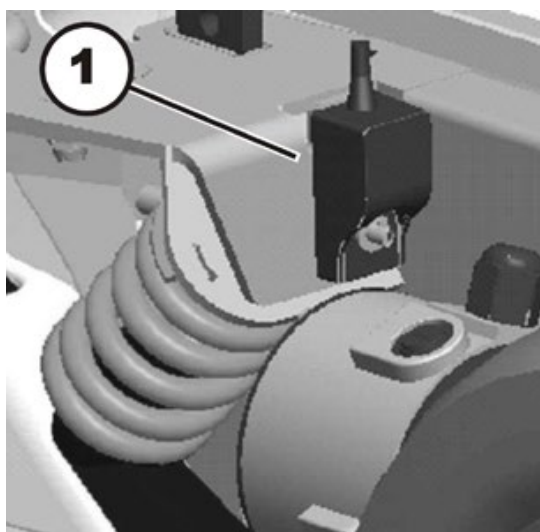

- (1) – G-Trac sensor (optional)



4.2 Electronic modules

Various different types of electronic modules can be installed in the wheelchair.

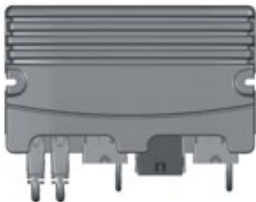
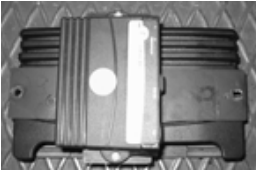
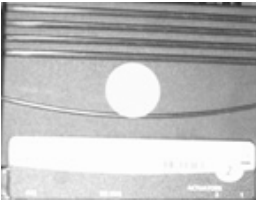
Before you connect components of the wheelchair such as adjustment motors or actuators to the electronic module, make sure you know exactly which electronic module is installed. The following table provides an overview.

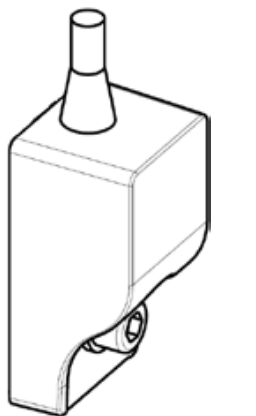
Electronic modules	Designations	Remotes	Remarks
 	ACS2 PMB70 ACS2 PMB70L ACS2 PMA90LG ACS2 with actuator module ACT	G90A REM A REM B REM 550 REM24	The actuator module is optional.
	Actuator module ACT		The actuator module is optional.
	Lighting circuit board		The lighting circuit board is optional.
	G-Trac sensor		The G-Trac sensor is optional

4.2.1 ACS2 PMB70 / ACS2 PMB70L electronic module

Connections

- 1) Battery 24V
- 2) Bus cable (to remote or ACT)
- 3) Bus cable (to remote or ACT)
- 4) Motor M1
- 5) Light
- 6) Motor M2

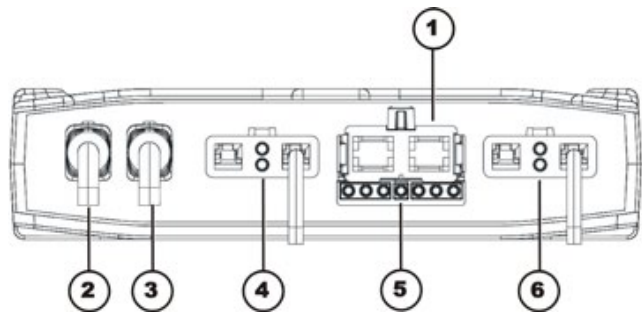

Rubber stoppers for free slots

- 2) & 3) Order number: 1552876

4.2.2 ACS2 PMA90L electronic module

Connections

- 1) Battery 24V
- 2) Cable to G-Trac sensor (GYRO)
- 3) Bus cable (to remote or ACT)
- 4) Motor M1
- 5) Light
- 6) Motor M2

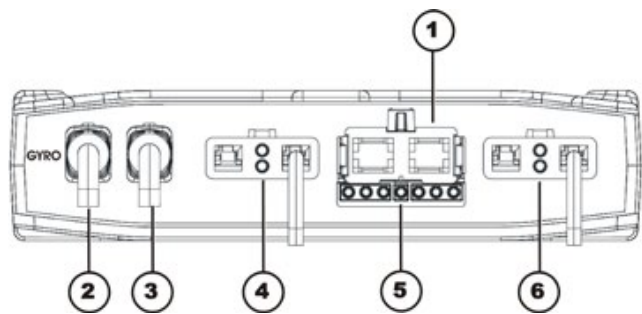

4.2.3 Actuator module ACT

Various types of adjustment motors, also called actuators, can be installed on the wheelchair. These actuators are either connected directly to the electronic module or to a separate actuator module. The actuator module is connected to the electronic module via a bus cable.

4.2.3.1 Actuator module ACT 2

Connections

- 1) ACI*
- 2) Bus cable (to remote or ACT)
- 3) Bus cable (to remote or ACT)
- 4) Adjustment motor/actuator - channel 2
- 5) Adjustment motor/actuator - channel 1

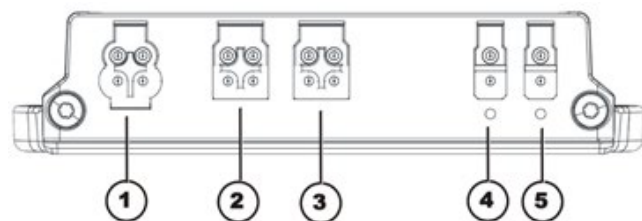

Rubber stoppers for free slots

- 1) Order number: 1555701
- 2) & 3) Order number: 1552876
- 4) & 5) Order number: 1555700

* The ACI connection serves to limit the movement of an actuator or to reduce velocity.

4.2.3.2 Actuator module ACT 4

Connections

- 1) ACI*
- 2) Bus cable (to remote or electronic module)
- 3) Bus cable (to remote or electronic module)
- 4) Actuator - channel 4
- 5) Actuator - channel 3
- 6) Actuator - channel 2
- 7) Actuator - channel 1

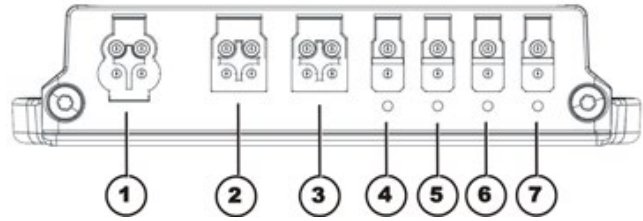

Rubber stoppers for free slots

- 1) Order number: 1555701
- 2) & 3) Order number: 1552876
- 4) to 7) Order number: 1555700

* The ACI connection serves to limit the movement of an actuator or to reduce velocity.



4.2.4 Lighting circuit board



The connections of the lighting circuit board are located directly on the board.

4.3 Remotes

Various types of remotes can be installed on the wheelchair.

Before you connect components of the wheelchair such as adjustment motors or actuators, make sure you know exactly which remote is installed. The following table provides an overview.

Remotes	Designations	Remarks
	REM G90A	Can be connected to - ACS2 PMB70 - ACS2 PMB70L - ACS PMA90LG power modules.
	REM A	Can be connected to - ACS2 PMB70 - ACS2 PMB70L - ACS PMA90LG power modules.

Remotes	Designations	Remarks
	<p>REM B</p>	<p>Can be connected to</p> <ul style="list-style-type: none"> - ACS2 PMB70 - ACS2 PMB70L - ACS PMA90LG <p>power modules.</p>
	<p>REM 550</p>	<p>Can be connected to</p> <ul style="list-style-type: none"> - ACS2 PMB70 - ACS2 PMB70L - ACS PMA90LG <p>power modules.</p>

5 Maintenance plan (once a year)



CAUTION!

Danger of injury and damage to property, if the maximum speed reduction on a wheelchair with a lifter does not function correctly!

The wheelchair's control unit must reduce the maximum possible speed as soon as the lifter is raised.

- Test the maximum speed reduction for correct function after any maintenance work or modifications to the wheelchair.

Component	Check for	Measures	Remarks	Ü
Restraining belt	• Damage to the restraining belt	• If the belt is damaged, replace it.	See chapter 9.1	
	• Function of the belt buckle	• If the belt is damaged, replace it.	See chapter 9.1	
Armrests	• Damage to the armrests	• If the arm pad is damaged, replace it.		
	• Fixation of the armrests	• Tighten screws		
Side Parts	• Damage to the side parts	• Replace the side parts if damaged		
	• Fixation screws of the side parts	• Tighten screws		
Electric backrest (if available)	<ul style="list-style-type: none"> • Damage to the backrest • Seams • Fastening • Check cable • Check function 	<ul style="list-style-type: none"> • Replace parts if damaged • Tighten screws • Replace cable or motor if necessary 		
Frame (chassis) / battery compartment	• Check fastenings, welding seams and battery box	<ul style="list-style-type: none"> • Tighten screws • Replace parts if necessary 		
Wheel suspension and wheels	• Check tight fit of the drive wheels and axial run out	• Adjust, replace wheel hubs	See chapter 8.8.1 and 8.8.3	
	• Check tight fit of steering wheels, Check required motor-to-body clearance and axial run out	• Replace wheels, wheel fork or wheel bearing	See chapter 8.7	
	• Tyres	• Repair or replace if damaged	See chapter 8.8.2	
	• Check suspension	• Repair or replace if damaged	See chapter 8.9	
	• Check directional stability	• Replace wheels, wheel fork or wheel bearing	See chapter 8.7 and 8.8	

Component	Check for	Measures	Remarks	
Drive units, coupling mechanism	<ul style="list-style-type: none"> • Motors 	<ul style="list-style-type: none"> • Check motors 	See chapter 7.1	
	<ul style="list-style-type: none"> • Check functions during drive operation and when pushing • Check coupling mechanism 	<ul style="list-style-type: none"> • Check the carbon brushes, replace if necessary • Replace motor if necessary • Tighten screws/nuts, adjust or replace if necessary 	See chapter 8.11.1 and 8.11.4	
Brakes	<ul style="list-style-type: none"> • Motor brake check 	<ul style="list-style-type: none"> • Check the motor brake 	See chapter 7.2	
Legrests	<ul style="list-style-type: none"> • Check welding seams, locking devices, screws and foot plates 	<ul style="list-style-type: none"> • Tighten, replace if necessary 	See chapter 8.14 & the User Guide	
Electric legrests (if available)	<ul style="list-style-type: none"> • Check cable • Check contacts • Check functions 	<ul style="list-style-type: none"> • Replace cable if necessary 	See chapter 8.14 & the User Guide	
Lighting (if available)	<ul style="list-style-type: none"> • Check cable • Check function 	<ul style="list-style-type: none"> • If necessary, replace light or cable 	See chapter 8.6	
Battery box	<ul style="list-style-type: none"> • Check battery box and fastening belt for damage 	<ul style="list-style-type: none"> • Replace if necessary 		
Batteries	<ul style="list-style-type: none"> • Check batteries for damage 	<ul style="list-style-type: none"> • Replace batteries if necessary 	See chapter 8.4.1 and 8.4.3	
	<ul style="list-style-type: none"> • Check battery voltage 	<ul style="list-style-type: none"> • Charge batteries 		
	<ul style="list-style-type: none"> • Check battery voltage 	<ul style="list-style-type: none"> • Charge batteries 	See instruction manual	
	<ul style="list-style-type: none"> • Check contacts and terminal clamps 	<ul style="list-style-type: none"> • Clean contacts and terminal clamps 	See the safety notes in chapter 8.4.1 and 8.4.3 for information on correctly handling batteries	

Component	Check for	Measures	Remarks	ü
Remote / electronic module	<ul style="list-style-type: none"> Remote, status display flashing 	<ul style="list-style-type: none"> Analyse the error / flash code 	See chapter 6.2	
	<ul style="list-style-type: none"> Fixations 	<ul style="list-style-type: none"> Tighten fixations, replace if necessary 		
	<ul style="list-style-type: none"> Cables and plug-in connections 	<ul style="list-style-type: none"> Check all cables and plug-in connections for secure fit, replace if necessary 		
	<ul style="list-style-type: none"> Joystick function 	<ul style="list-style-type: none"> Replace joystick if necessary Replace remote if necessary 		
	<ul style="list-style-type: none"> Power supply 	<ul style="list-style-type: none"> Check all cables and plug-in connections for secure fit, replace if necessary 		
Drive program	<ul style="list-style-type: none"> Check the version of the program in the driving electronic. 	<ul style="list-style-type: none"> Update the software if a newer version is available. 	See chapter 8.3	

6 Operational faults

The various electronic modules can be fitted in connection with differing remotes in the mobility aid. Rectification of operational faults is dependent on the electronic module fitted.

The electronic modules used are described in Chapter 4.2.



Note

The tables for rectification of operational faults listed in the following chapters are only an excerpt from the original manufacturer's manuals.

You can obtain the original manuals from Invacare®.

If you have problems with the mobility aid, please proceed as follows:

- First assess the possible cause of the problem using the following table.
- Check the remote status display. Evaluate the error code.
- Carry out the necessary checks and repairs as recommended in the following table.

6.1 Drive fault diagnosis

PROBLEM	OTHER SYMPTOMS	POSSIBLE CAUSE	SOLUTION	DOCUMENTATION
Mobility aid will not start	The remote status display illuminates normally and displays blink code 5/6.	Drive motors disengaged	Engage drive motors	See operating manual
	Remote status display does not illuminate	Batteries defective	Replace batteries	See chapter 8.4.1.
		Completely discharge battery	Pre-charge batteries	See operating manual
		Power supply to remote interrupted	Check master fuse	See chapter 8.4.4.
			Check cables between the modules for loose connections and damage	See chapter 8.4.5.
	Remote defective	Replace remote	See chapter 8.2.1.	
Remote status display blinking	Various causes	Assess error code	See chapter 6.2.	
Mobility aid judders in drive mode	None	Batteries defective (unstable voltage)	Replace batteries	See chapter 8.4.1.
		Drive motor(s) defective	Replace motor(s)	See chapter 8.11.1.
			Replace carbon brushes	See chapter 8.11.4.
Mobility aid pulls to left or right	None	Drive motors running asymmetrically	Change programming to synchronise motors.	See chapter 8.3.
Error message does not go out	None	Bad connections	Check all connecting cables.	See chapter 8.4.5.
		Motor brake defective	Measure internal resistance of brakes, replace motor if defective.	See chapters 7.2 and 8.11.1
Motors stop and start irregularly	None	Voltage decline	Stop journey and allow electronic to cool down.	
Motor runs but loses power	None	High motor loading causes	Stop journey and allow electronic to	

PROBLEM	OTHER SYMPTOMS	POSSIBLE CAUSE	SOLUTION	DOCUMENTATION
		electronic module to decrease voltage	cool down.	
Motors stop and do not start again	None	High motor loading causes electronic module to decrease voltage	Leave mobility aid switched on and allow electronic module to work. Charge batteries overnight with mobility aid switched on.	
	None	Fuse burnt out	Check cabling and replace fuse	See chapters 8.4.5 and 8.4.4
	None	Motor defective	Check carbon brushes and replace if necessary	See chapter 8.11.4.
			Measure internal resistance of motor, replace motor if defective.	See chapters 7.1 and 8.11.1
	None	Electronic module defective	Replacing the electronic module	See chapter 8.2.2.
Motors lose power during journey	None	Bad connections	Switch mobility aid off, wait 10 seconds, switch mobility aid on again. Check all cabling.	See chapter 8.4.5.
Motor judders or runs irregularly, or only one motor runs	None	Carbon brushes worn	Check carbon brushes and replace if necessary	See chapter 8.11.4.
		Clutch(es) defective	Replace clutch	See chapter 8.11.3.
		Bearing defective	Replacing the motor	See chapter 8.11.1.
		Collector defective	Measure internal resistance of motor, replace motor if defective.	See chapters 7.1 and 8.11.1
Motors do not run	None	Bad connections	Check all cabling.	See chapter 8.4.5.
		Fuse burnt out	Check cabling and replace fuse	See chapters 8.4.5 and 8.4.4
		Batteries defective	Replace batteries	See chapter 8.4.1.

PROBLEM	OTHER SYMPTOMS	POSSIBLE CAUSE	SOLUTION	DOCUMENTATION
		Cabling to electronic module or joystick defective	check cabling	See chapter 8.4.5.
		Electronic module defective	Replacing the electronic module	See chapter 8.2.2.
	Corroded contacts	Water, salt or urine has penetrated	Check cabling, replace if necessary.	See chapter 8.4.5.
Motor makes clicking noise	None	Clutch(es) defective	Replace clutch	See chapter 8.11.3.
		Bearing defective	Replacing the motor	See chapter 8.11.1.
		Collector defective	Measure internal resistance of motor, replace motor if defective.	See chapters 7.1 and 8.11.1
Scraping noise or motor blocked	None	Clutch(es) defective	Replace clutch	See chapter 8.11.3.
		Bearing defective	Replacing the motor	See chapters 8.11.1 and 8.11.3
		Transmission defective	Replace transmission.	See chapters 8.11.1 and 8.11.3
Transmission makes clicking noise	None	Transmission defective	Replace transmission.	See chapters 8.11.1 and 8.11.3
		Drive wheel loose	Tighten drive wheel, secure bolts with Loctite if necessary	See chapter 8.8.1.
Transmission losing oil	None	Sealing ring on drive shaft defective	Replace transmission if sealing ring defective.	See chapters 8.11.1 and 8.11.3
			Check carbon brushes for oil wetting, replace motor if brushes wet	See chapters 8.11.1, 8.11.3 and 8.11.4
Irregular running	None	Drive shaft movable or bent	Check drive shaft, replace transmission if defective.	See chapters 8.11.1 and 8.11.3
Parts lost	None	Parts lost	Reattach parts once found.	
Batteries not being charged	None	Fuse burnt out, cable defective	Check cabling and replace fuse	See chapters 8.4.5 and 8.4.4

PROBLEM	OTHER SYMPTOMS	POSSIBLE CAUSE	SOLUTION	DOCUMENTATION	
		Batteries defective	Replace batteries	See chapter 8.4.1.	
	LEDs blinking on charging unit	Charging unit defective	Replace charging unit	See charging unit operating manual	
Short charging period	None	One of the batteries could be defective	Replace batteries	See chapter 8.4.1.	
Mobility aid runs too slowly	None	Remote defective	Replace remote	See chapter 8.2.1.	
		Batteries defective	Replace batteries	See chapter 8.4.1.	
Actuator does not react	Remote shows blinking "E" ¹ or blink code 2 ² Status diode on lighting/actuator module does not go out even if the remote has been switched off or disconnected	Lighting / actuator module defective	Replace lighting / actuator module	See chapter 8.2.2.	
		None	Cable disconnected or damaged	Safeguard cable connection, replace cable if necessary	See chapter 8.4.5.
			Electrical adjusting motor defective	Check adjusting motor	
	Remote defective	Replace remote	See chapter 8.2.1.		

¹ Only applies to remote SD24

² All remotes except SD24

6.2 REM remotes: Error codes and diagnostic codes



Note

The following table is applicable to remotes G90A, REM A, REM B und REM 550, which are connected to electronic modules ACS2 PMB70, ACS2 PMB70L, ACS2 PMB90LG.

The drive electronic can automatically rectify some faults. In this case the status display will stop blinking. Switch the remote on and off again several times. Wait around 5 seconds each time before switching the remote on again. If this does not rectify the fault, determine the cause using the blink codes from the following table.

BLINK CODE	POSSIBLE CAUSE	SOLUTION	DOCUMENTATION
1 x blink	Module defective	Replace defective module	See chapter 8.2.2.
2 x blink	Accessory error (e.g. short-circuit in adjusting motor)	Check accessory connections, check accessory	See chapter 8.4.5.
	Lifter too high or too low (seat not at driving height)	If the lifter is raised, lower it slowly until the status display stops blinking. If the lifter is too low, raise it slowly until the status display stops blinking. Only drive when the seat is at driving height.	See operating manual
3 x blink	Fault on left-hand motor (M2). Connection loose/defective or motor defective	Check connection plug, check motor	See chapters 8.4.5 and 7.1
4 x blink	Fault on right-hand motor (M1). Connection loose/defective or motor defective	Check connection plug, check motor	See chapters 8.4.5 and 7.1
5 x blink	Fault/brake fault on left-hand motor (M2). Connection loose/defective or motor defective	Check connection plug, check motor	See chapters 8.4.5 and 7.1
6 x blink	Fault/brake fault on right-hand motor (M19). Connection loose/defective or motor defective	Check connection plug, check motor	See chapters 8.4.5 and 7.1
7 x blink	Completely discharge battery	Pre-charge battery	See operating manual
8 x blink	Battery voltage too high	Switch lighting to low battery voltage Check battery charger	See charging unit operating manual
9 or 10 x blink	Faulty data transmission between modules	Remove electronic modules except for the power module and the remote. Replace the modules one after another in order to ensure which was the one causing the fault.	See chapter 8.2.2.

BLINK CODE	POSSIBLE CAUSE	SOLUTION	DOCUMENTATION
11 x blink	Drive motors overloaded / overheated	Switch remote on and off / wait if necessary	-
12 x blink	Compatibility problems between modules	Remove incorrect module	See chapter 8.2.2.

6.3 Diagnosis of charging device faults

SYMPTOM	POSSIBLE CAUSE	SOLUTION
No LEDs illuminating on battery charger	Charging device not connected to mains supply.	Ensure that the battery charger has been plugged in.
	No mains supply	Check the mains supply with a voltmeter.
	Defective mains supply cable.	Check the mains supply cable. Replace damaged cables or send the battery charger to Invacare® Service for repair.
	LEDs are burnt out	Send the battery charger to Invacare® Service for repair.
	An internal fuse might be burnt out.	Send the battery charger to Invacare® Service for repair.
Batteries do not charge	Fuse on mobility aid has burnt out.	Check mobility aid fuses. See chapter 8.4.4.
	Battery charger not connected to mobility aid.	Ensure that the battery charger has been connected to the mobility aid.
	No mains supply	Check the mains supply with a voltmeter.
	Defective mains supply cable.	Check the mains supply cable. Replace damaged cables or send the battery charger to Invacare® Service for repair.
	Battery charger could be defective.	Use a battery charger which you know is working properly to charge the batteries. Send the defective battery charger to Invacare® Service for repair.
	Battery voltage is too low to operate mobility aid.	Replace the batteries. See chapter 8.4.1.

7 Test procedures

7.1 Testing the motor



Requirements:

- Phillips screwdriver size 2
 - digital multimeter with resistance measurement
-
- Remove the rear panel as described in Chapter 8.1.2.

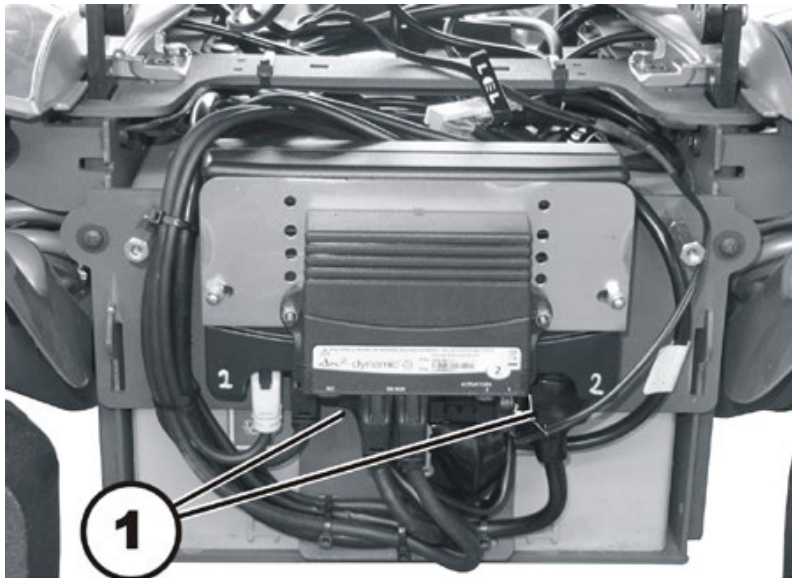

- Pull the motor plug (1) out of the electronic module.

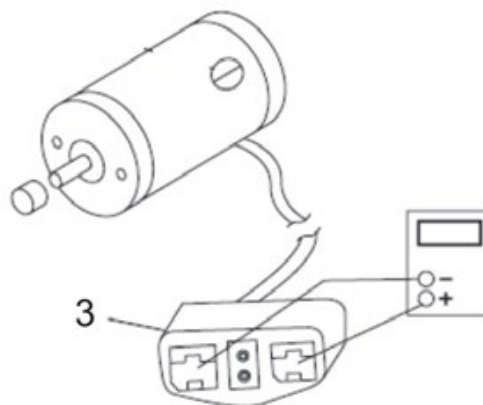

- Connect the digital multimeter to the motor plug contacts (3) and measure the resistance between the contacts.



Note

A resistance of between 0.5 and 5 ohms indicates a motor ready for operation.

A resistance of between 15 ohms and infinity indicates a defective motor. High resistances are normally caused by bad connections or worn carbon brushes.

7.2 Testing the electro-mechanical parking brake



Note

This test should only be carried out on mobility aids with conventional motor/transmission units.



Requirements:

- Phillips screwdriver size 2
 - digital multimeter with resistance measurement
-
- Remove the rear panel as described in Chapter 8.1.2.

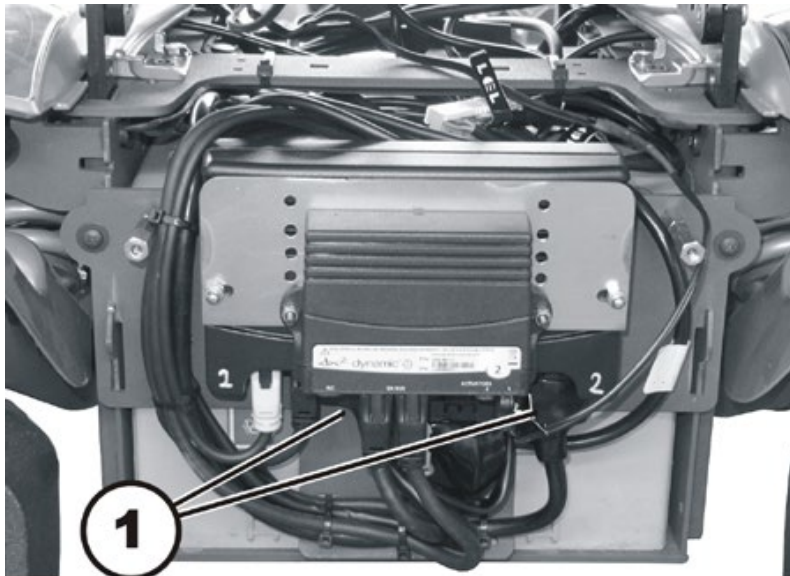

- Pull the motor plug (1) out of the electronic module.

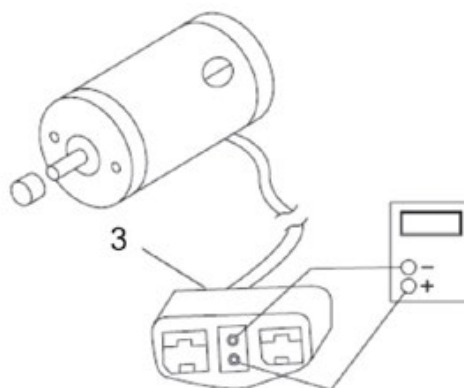

- Connect the digital multimeter to the adjacent central motor plug contacts (3) and measure the resistance between the contacts.
- If there is a defect, replace the motor and send it to Invacare® Service for inspection or repair.



Note

A resistance of between 40 and 80 ohms indicates an intact brake.

A resistance of 0 ohms or a very high resistance (mega-ohms or infinity) indicates a short-circuit, a bad connection or a defective brake.

**CAUTION!**

Material damage can be caused to the electronic module due to short-circuit in the electro-mechanical brake.

- *NEVER connect an electro-mechanical brake to an intact electronic module with a short-circuit!*
 - *Always replace short-circuited brakes immediately.*
-

**Note**

A defective motor can damage the electronic module, but not the other way around.

8 Repair Work



CAUTION!

Danger of injury and damage to property, if the maximum speed reduction on a wheelchair with a lifter does not function correctly!

- *The wheelchair's control unit must reduce the maximum possible speed as soon as the lifter is raised.*
- *Test the maximum speed reduction for correct function after any maintenance work or modifications to the wheelchair.*

8.1 Covers

8.1.1 Open front cover

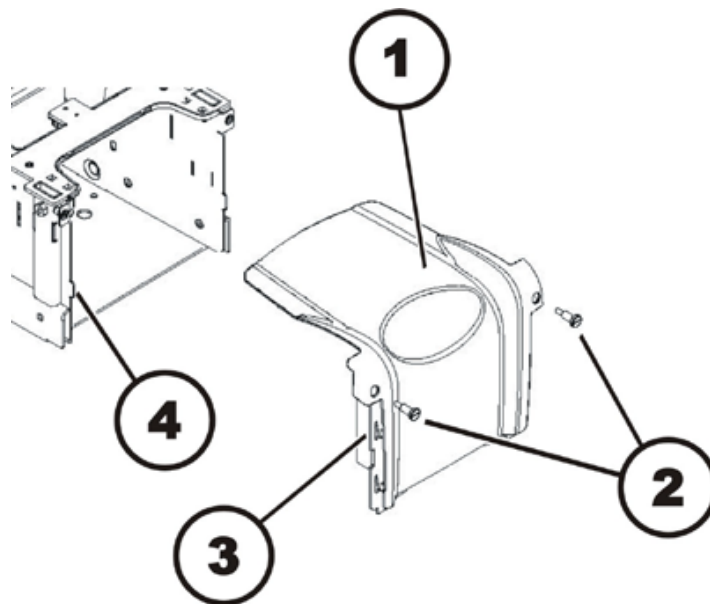

Removing the front cover:

- Remove the leg rests.
- Loosen and remove both of the knurled head screws (1).
- Press the front cover (2) slightly upward, then pull the cover forward and off.

Installing the front cover:

- Assemble the parts in reverse order.
- When installing the plastic cover, make sure that the slots on the sides (3) and the lower hooks on the cover latch onto the chassis (4).
- Tighten both knurled head screws hand-tight.

8.1.2 Opening the rear cover

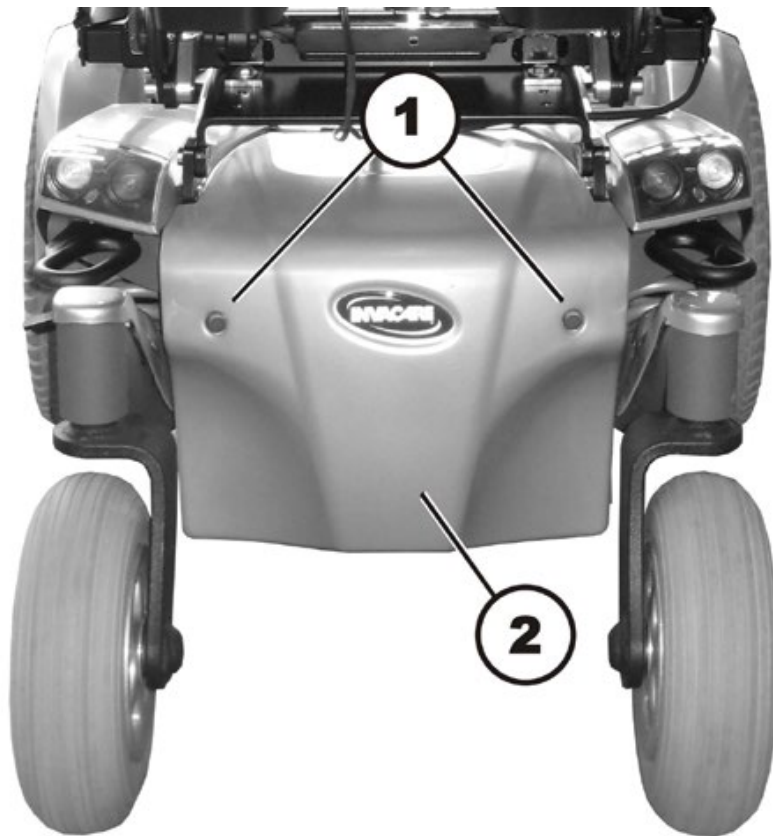
**Removing the rear cover:**

- Loosen and remove both of the knurled head screws (1).
- Remove the rear cover (2).

Installing the rear cover:

- Assemble the parts in reverse order.
- Tighten both knurled head screws hand-tight.

8.1.3 Opening the lateral cover

**Requirements:**

- 10 mm socket wrench
- 6 mm Allen key
- Two oblong wooden blocks, at least 14 x 14 x 30 cm

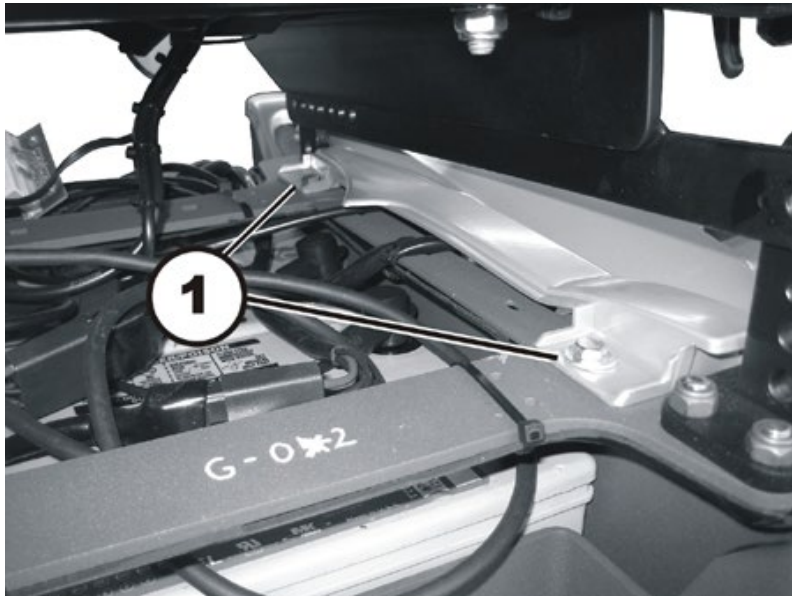
**Removing the lateral cover:**

- Remove the drive wheel, as described in chapter 8.8.1.
- Remove the front cover and the rear covers, as described in chapters 8.1.1 and 8.1.2.
- Use the 10 mm socket wrench to loosen both screws (1).
- Hold the cover firmly with one hand.
- Completely remove both screws (1) including the washers.
- Pull the cover off towards the side.
- Disconnect the plug-in connections if there are tail lights installed in the lateral cover (see illustration below).

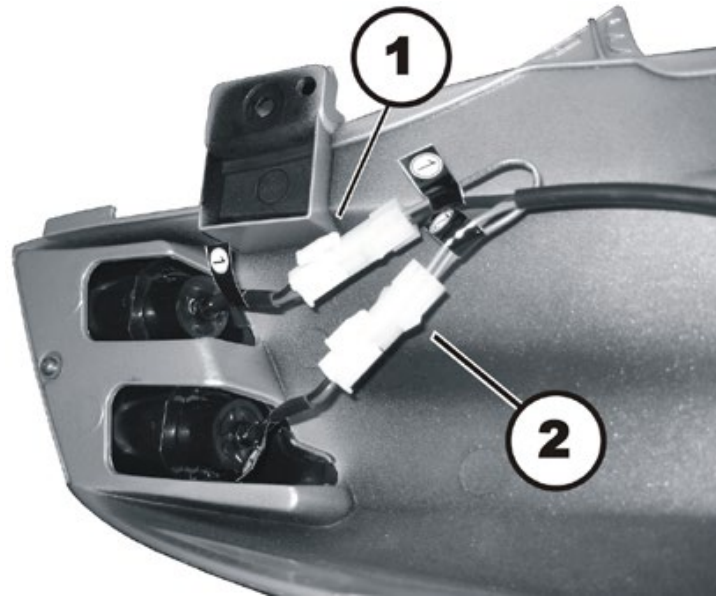

Installing the lateral cover:

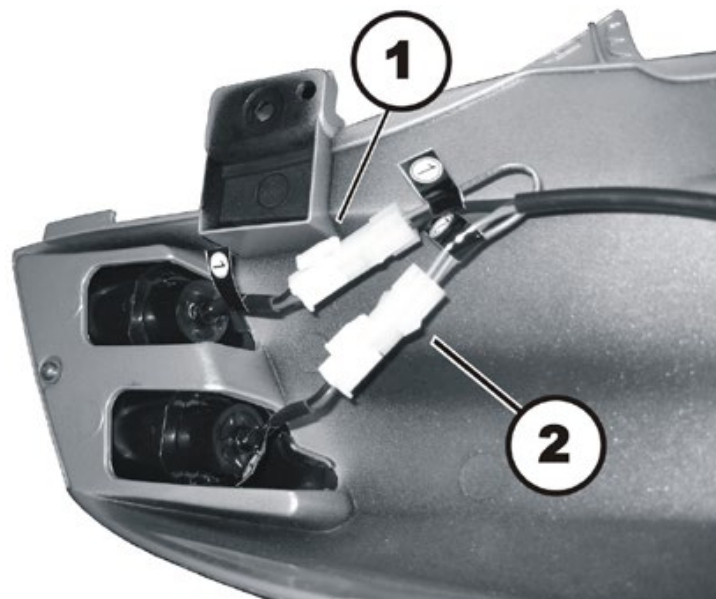

- Connect the plug-in connections if there are tail lights installed in the lateral cover. Make sure that the markings (1 = red tail light) and (2 = yellow flasher) on the power supply cable and on the tail light plug-in connection are aligned with each other.

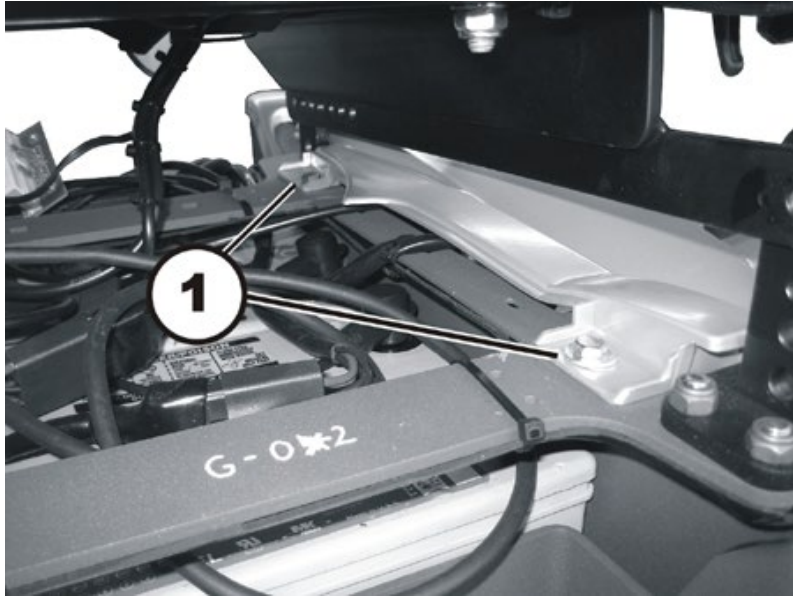

- Push the cover from the side between the seat and the chassis.
- Position both screws (1) including the washers and tighten the screws hand-tight.

8.1.4 Opening the cover of the rear wheel cantilever arm

**Requirements:**

- 4 mm Allen key

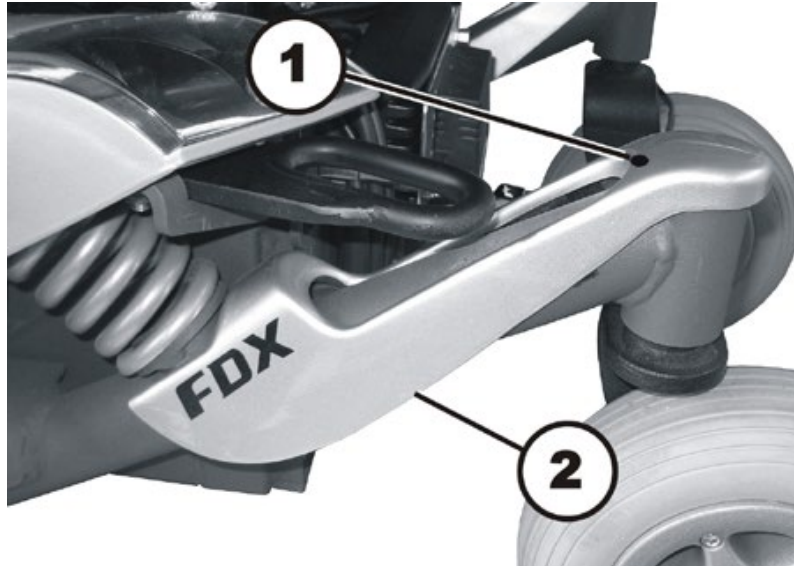
**Removing the rear cover:**

- Use the 4 mm Allen key to loosen and remove the hexagon socket head screw (1).
- Pull the cover up in the rear and remove it. The cover is held in place by additional Velcro fasteners.

Installing the rear cover:

- Assemble the parts in reverse order.

8.2 Electronic modules

8.2.1 Replacing remotes

**Note**

The procedure to replace remotes is trivial and is not described in detail.

However, when replacing a REM remote in connection with a DX, ACS or ACS2 electronic module, please make sure to select the correct drive programme as described in chapter 8.2.4.

8.2.2 Replacing electronic modules

**Note**

When replacing a REM remote in connection with a DX, ACS or ACS2 electronic module, please make sure to select the correct drive programme as described in chapter 8.2.4.

Various different types of electronic modules can be installed in connection with different remotes in the wheelchair. The electronic modules that might be installed are described in chapter 4.2.

The procedure to replace components is described using the ACS2 electronic module with an optional lighting circuit board and optional actuator module as an example. The procedure is identical for other electronic modules. The only difference is the position of the plug-in connections.

**WARNING!**

Every alteration to the drive programme can influence vehicle handling and the tipping stability of the wheelchair!

- *Alterations to the drive programme must only be carried out by authorised Invacare® dealers!*
- *Invacare® can only assume a warranty for the safe vehicle handling of the wheelchair – in particular tipping stability - for this standard, unaltered drive programme!*

**Note**

All electronic modules are supplied with a standard drive programme. If you have performed customer-specific modifications to the drive programme, then these will need to be recreated manually after installing the new electronic module.

**Requirements:**

- 7 mm socket wrench
- 8 mm socket wrench
- To modify a drive programme you will need:
Programming software or a hand-held programming device and the installation manual, available from Invacare®.

Uninstalling electronic modules:

- Remove the rear cover, as described in chapter 8.1.2.

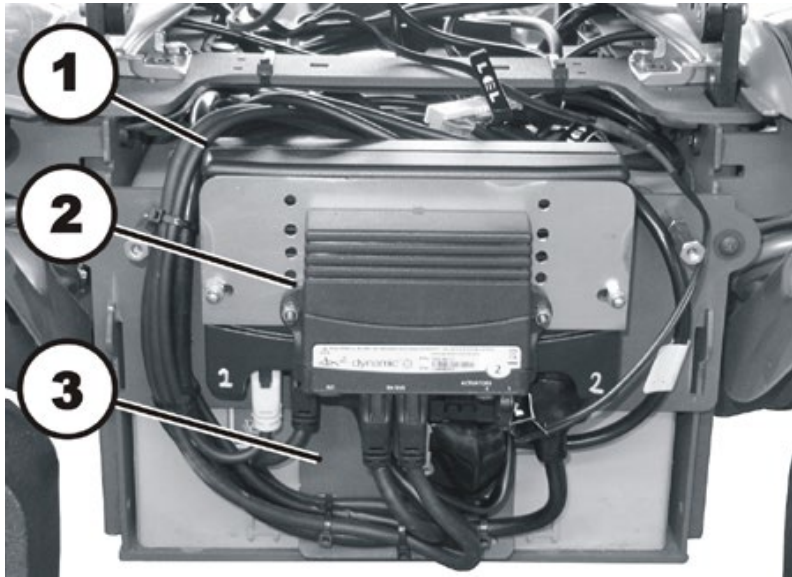

- Take exact note of the positions of all cables and the sockets that they are connected to. Mark the connectors and sockets or take a photograph with a digital camera.
- The illustration shows the electronic module (1) and the optional actuator module (2). The optional lighting circuit board is not shown in the picture, but it would be installed at position (3) if it was present.

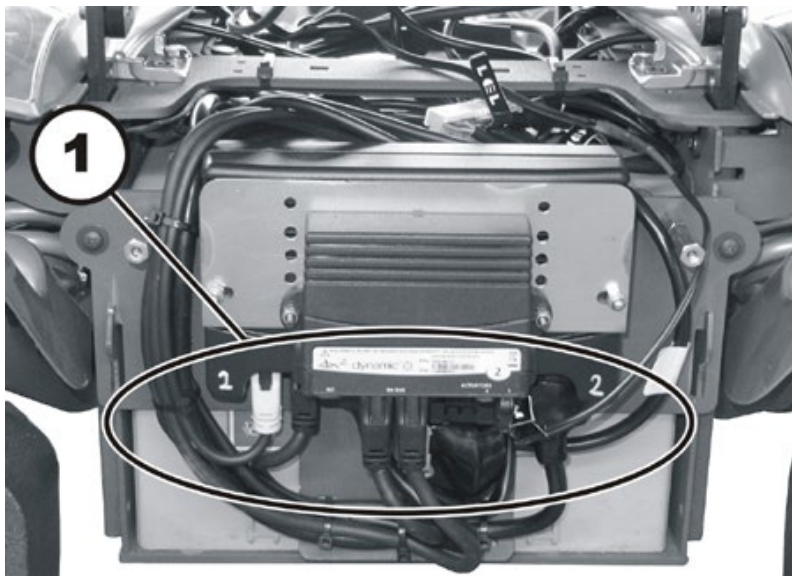

- Disconnect the plugs (1) from the electronic module and, if installed, from the optional actuator module and the optional lighting circuit board.

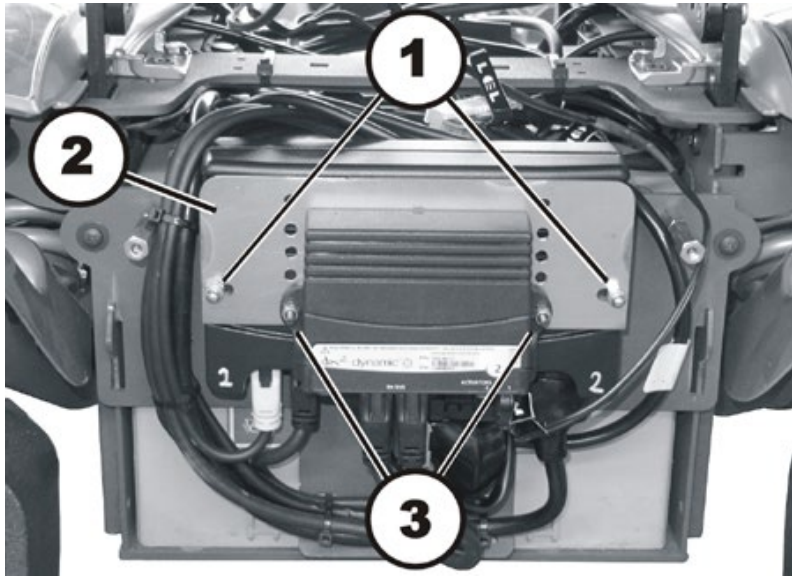

- Use the 8 mm socket wrench to loosen and remove the nuts (1).
- Remove the actuator module together with the mounting plate (2).
- If the actuator module is to be replaced:
Use the 7 mm socket wrench and a Phillips screwdriver to loosen and remove the nuts (3).
- If the electronic module is to be replaced:
Remove the electronic module.
- Replace the defective modules.

Installing electronic modules:

- Install the various modules in reverse order.
- Reconnect all cable connectors to their former positions.
- If you have replaced ACS2 electronic module, please select the correct drive program, as described in chapter 8.2.4.
- Update the drive program, in case a new software version is available, as described in chapter 8.3.
- Modify the drive program using the programming software as needed.
- The last step is to test all functions of the vehicle.

8.2.3 Replacing the G-Trac sensor

**Requirements:**

- 10 mm socket wrench
- Side cutting pliers
- Cable ties

Uninstalling the G-Trac sensor:

- Switch the electronic of the wheelchair OFF.
- Remove the front, rear and right lateral covers, as described in chapter 8.1.1, 8.1.2 and 8.1.3.

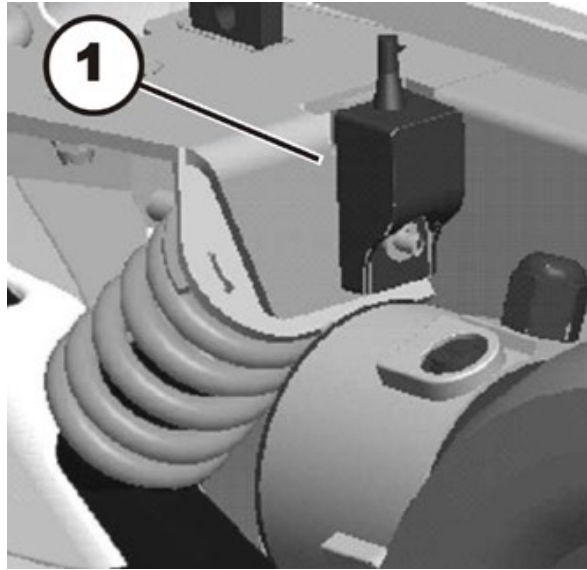

The G-Trac sensor is located on the spring-seat of the right-hand spring.

- Trace the cable of the G-Trac sensor (1) to the electronic module and disconnect it there.
- Pull the cable out of the wheelchair. If necessary remove any attached cable ties.

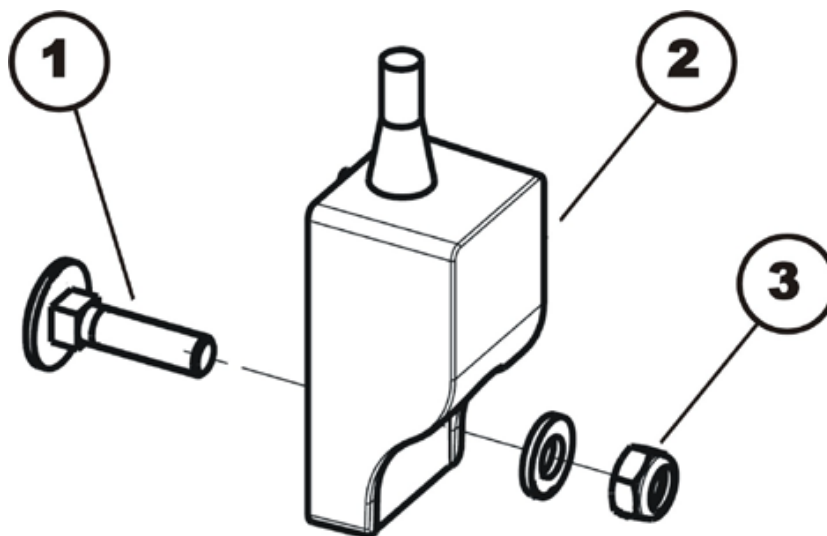

- Use the 10 mm socket wrench to loosen and remove the self-securing nuts (3) including the washers.
- Pull the G-Trac sensor (2) off of the carriage bolt (1) which is inserted in the spring seat.
- Replace the G-Trac sensor.

Installing the G-Trac sensor:

- Assemble the parts in reverse order.
- Reconnect all cable connectors to their former positions.
- The G-Trac sensor must be installed with the cable pointing upwards.
- The last step is to test all functions of the vehicle.

8.2.4 Drive program selection after component replacement

The drive program is saved in the REM remote, and also in the DX, ACS or ACS2 electronic module. If one of these two components is replaced, the system must be told which of the components has not been replaced so that it knows which contains the current controller profile.



Note

The system allows normal usage of the mobility aid after component replacement only if the profile is selected afterwards.

8.2.4.1 Profile selection with G90A remote

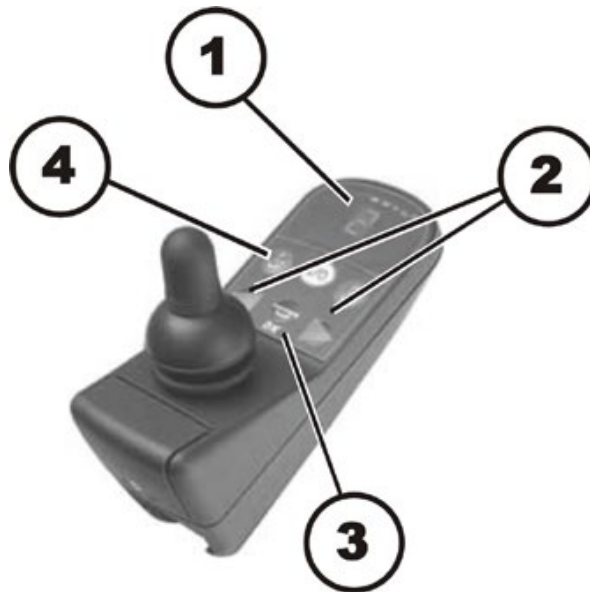

- Connect the plug to the remote or the ACS2 electronic system, respectively.
- The display (1) will indicate that you should select a profile.
- Use the arrow keys (2) to select the location where the desired controller profile is stored:
 - I = Remote
 - II = Electronic module
- The display will indicate which profile you have selected.
- Press the "Horn" key (3) and the "Drive Mode" key (2) and keep them pressed for 3 seconds to confirm the selection.
- The system switches itself off and starts again automatically. During this process, the selected profile is stored in the remote as well as in the electronic module.

8.2.4.2 Profile selection with remote REM A or REM B



- Plug the plug into the remote or the ACS2 controller.
- LEDs (1) and (4) blink.
- Use the bottom rocker switch (5) to select where the required controller profile is saved.
 - LED 1 = remote
 - LED 4 = ACS2 control system
- The relevant LED illuminates permanently, the other LED is off.
- Press the "Horn" (2) and "+" (3) buttons on the speed selection and hold them down for 3 seconds to confirm the selection.
- The system will switch itself off and restart automatically. During the process, the selected profile will be saved both in the remote and in the electronic module.

8.2.4.3 Profile selection with remote REM 550



- Plug the plug into the remote or the ACS2 controller.
- The display (2) shows that you need to select a profile.
- Use the bottom rocker switch (3) to select where the required controller profile is saved.
 - I = remote
 - II = electronic module
- The display will show which profile you have selected.
- Press the "Horn" (4) and "+" (1) buttons on the speed selection and hold them down for 3 seconds to confirm the selection.
- The system will switch itself off and restart automatically. During the process, the selected profile will be saved both in the remote and in the electronic module.

8.3 Updating the driving program

The driving programs for electric wheelchairs are continually updated and improved by Invacare®. For this reason, you should check whether the version number is still up to date each time a wheelchair comes in for repairs, and also during regular inspections.

If a newer version is available, the driving program must be updated. The procedure for updating the driving program is described in the user manual of the Wizard software.



Note

The electronic system is supplied with a standard drive program. If the driving program has been customised, you have to perform this customisation again, after installing the new driving program. This also applies to the customer-specific options of the seat setting for ACS2 remotes, which are activated ex works.



WARNING: Every alteration to the drive program can influence vehicle handling and the tipping stability of the wheelchair!

- *Alterations to the drive program must only be carried out by trained Invacare®-dealers!*
 - *Invacare® can only assume a warranty for the safe vehicle handling of the wheelchair – in particular tipping stability - for unaltered standard drive programs!*
-



Pre-requisites:

- Dynamic® Wizard software
 - User manual for the Wizard software
 - For further information on other requirements - such as the minimum system configuration of the PC to be used for programming, necessary programming cables - see the user manual of the Wizard software. You find the latest version of the user manual in the download area on <http://www.dynamiccontrols.com/>.
-



Note

When an electrical adjustment option is retrofitted, such as electrical legrests, then this option needs to be activated in the driving program as well if you have an ACS2 remote. For more information, refer to the user manual of the Wizard software and the installation instructions for the electronic modules

8.4 Batteries, cables & battery chargers

8.4.1 Removing the batteries



CAUTION:

Danger of injury and danger of damage to property if the batteries are handled incorrectly!

- *The installation of new batteries may only be performed by authorised technicians.*
- *Pay attention to the warning notes on the batteries.*
- *Only use the battery type defined in the technical specifications.*



CAUTION:

Risk of fire and burns if battery terminals are short-circuited!

- *Take special care that the battery terminals are NOT short-circuited with a tool or metallic components of the wheelchair!*
- *Make sure that the battery terminal caps are fitted to the battery terminals at all times if you are not working on them.*



CAUTION: Danger of crushing!

The batteries are very heavy. There is a danger that you may injure your hands.

- *Take into account the heavy weight of the batteries.*
- *Handle the batteries carefully.*



WARNING: Risk of chemical burns!

Danger of injury by leaking acid.

- *Wear acid-resistant protective gloves when handling batteries.*
- *Wear protective goggles when handling batteries.*



How to deal with a battery acid leak:

- *Remove clothes that have been soiled or soaked with acid immediately!*
- *Immediately wash the affected area of skin that has come into contact with battery acid with lots of water!*



After contact with eyes:

- *Immediately rinse eyes under running water for several minutes! Consult an eye doctor immediately afterwards!*



Requirements:

- Phillips screwdriver, size 2
- Side cutting pliers
- Cable ties

Uninstalling the batteries:

- Remove the legrests.
- Remove the front cover, as described in chapter 8.1.1.

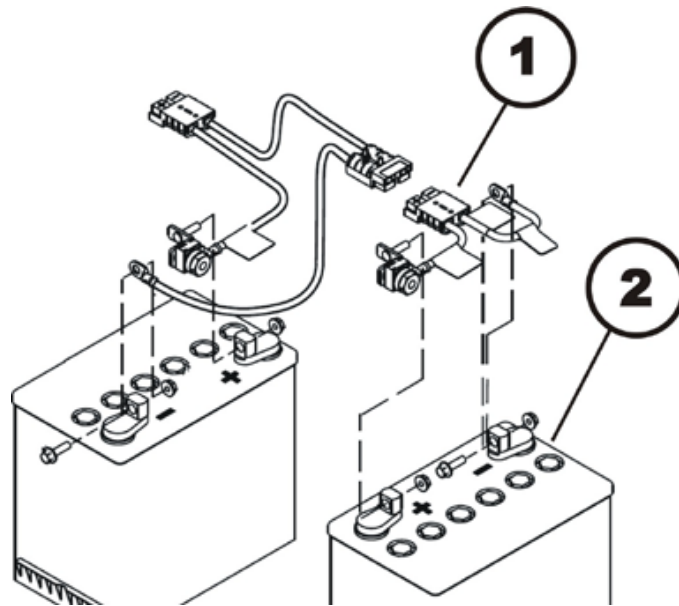

- Disconnect the plug-in connection (1) of the front battery (2).
- Remove the rear cover, as described in chapter 8.1.2.

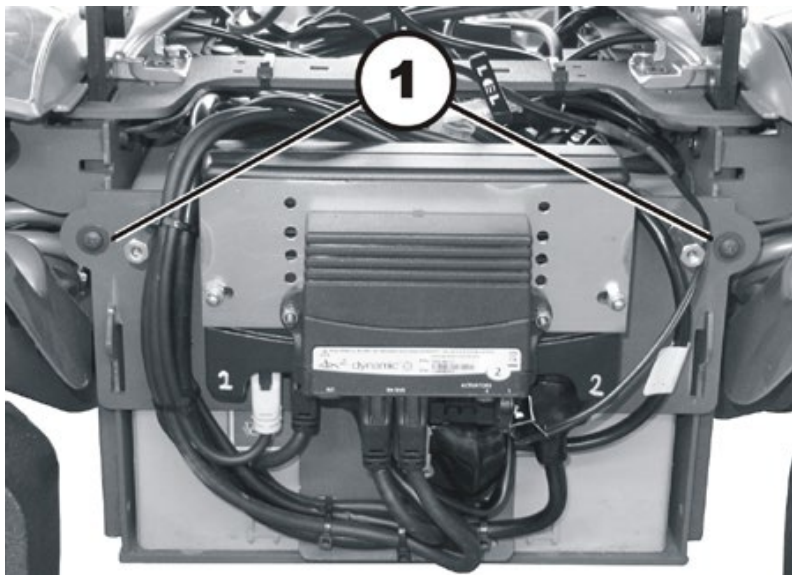

- Take exact note of the positions of all cables and the sockets that they are connected to. Mark the connectors and sockets or take a photograph with a digital camera.
- If necessary, remove the cable ties that secure the bundles of cables to the chassis on both sides of the electronic modules.
- Position the bundles of cables so that they lie outside of the fixation screws (1) of the electronic module brackets.
- Loosen and remove both fixation screws of the electronic module brackets including the washers with a Phillips screwdriver.

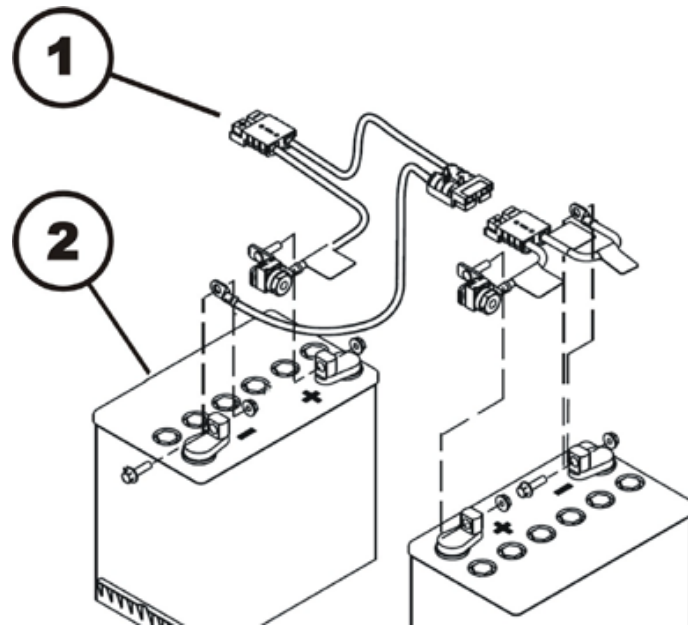

- Disconnect the plug-in connection (1) of the rear battery (2).
- Disconnect the battery cable from the electronic module.
- Lift the electronic module bracket up and remove it. Pull the bracket towards the rear and let it hang over the back end of the wheelchair.
- Pull both batteries backwards out of the chassis and remove them. Take into account the heavy weight of the batteries.

Installing batteries:

- Install the batteries in reverse order.
- Make sure the battery box sockets and plugs are correctly installed. A schematic showing the correct positions can be found in the battery box cover.

8.4.2 Replacing batteries / replacing battery cables



Note

To replace the fuse, the battery cable with the fuse attached to it must be replaced.



CAUTION:

Danger of injury and danger of damage to property if the batteries are handled incorrectly!

- *The installation of new batteries may only be performed by authorised technicians.*
- *Pay attention to the warning notes on the batteries.*
- *Only use the battery type defined in the technical specifications.*



CAUTION:

Risk of fire and burns if battery terminals are short-circuited!

- *Take special care that the battery terminals are NOT short-circuited with a tool or metallic components of the wheelchair!*
- *Make sure that the battery terminal caps are fitted to the battery terminals at all times if you are not working on them.*



CAUTION: Danger of crushing!

The batteries are very heavy. There is a danger that you may injure your hands.

- *Take into account the heavy weight of the batteries.*
- *Handle the batteries carefully.*



WARNING: Risk of chemical burns!

Danger of injury by leaking acid.

- *Wear acid-resistant protective gloves when handling batteries.*
- *Wear protective goggles when handling batteries.*



How to deal with a battery acid leak:

- *Remove clothes that have been soiled or soaked with acid immediately!*
- *Immediately wash the affected area of skin that has come into contact with battery acid with lots of water!*

After contact with eyes:

- *Immediately rinse eyes under running water for several minutes! Consult an eye doctor immediately afterwards!*



Requirements:

- 11 mm socket wrench
- Side cutting pliers
- Cable ties

Uninstalling batteries/battery cables:

- Remove the batteries, as described in chapter 8.4.1.

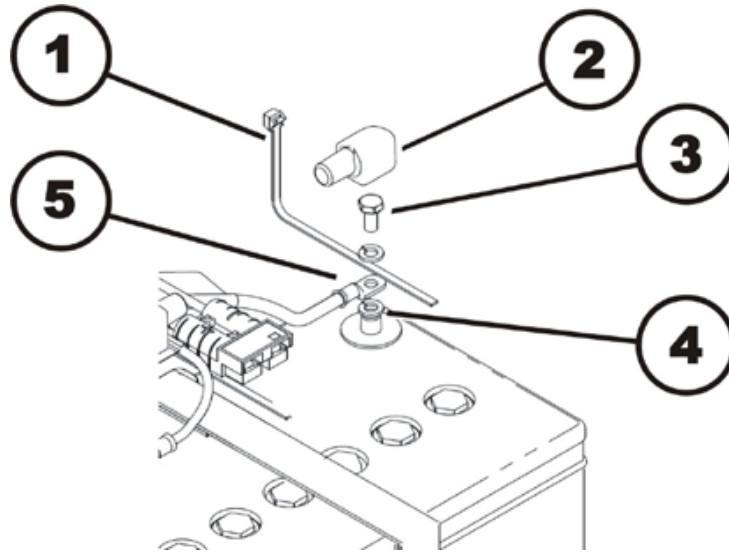
**Positive terminal (+):**

- Remove the cable ties (1) with side cutting pliers.
- Lift the battery terminal cap (2) off and move it up the cable and out of the way.
- Use an 11 mm socket wrench to loosen the battery terminal screw (3).
- Remove the battery terminal screw together with both washers and the cable lug (5) from the battery terminal (4).

Negative terminal (-):

- Repeat the steps of the procedure for the positive terminal on the negative terminal of the battery.
- Replace the batteries and/or the battery cables.

Installing batteries/battery cables:

- Assemble the parts in reverse order. Connect the negative terminal first, then the positive terminal.
- Make sure the battery box sockets and plugs are correctly installed. A schematic showing the correct positions can be found in the battery box cover.
- Carefully reposition the battery terminal caps and secure them with a cable tie to prevent them from possibly slipping out of place.

8.4.3 How to handle damaged batteries correctly



WARNING: Risk of chemical burns!

Danger of injury by leaking acid.

- *Wear acid-resistant protective gloves when handling batteries.*
- *Wear protective goggles when handling batteries.*



How to deal with a battery acid leak:

- *Remove clothes that have been soiled or soaked with acid immediately!*
- *Immediately wash the affected area of skin that has come into contact with battery acid with lots of water!*

After contact with eyes:

- *Immediately rinse eyes under running water for several minutes! Consult an eye doctor immediately afterwards!*



Requirements:

- Safety goggles
- Acid-resistant gloves
- Acid-resistant container for transportation

- Always wear appropriate safety clothing when handling damaged batteries.
- Place damaged batteries in an acid-resistant container immediately after removing them.
- Only ever transport damaged batteries in an appropriate acid-resistant container.
- Wash all objects that have come into contact with acid with lots of water.



Disposing of dead or damaged batteries correctly

Dead or damaged batteries can be given back to your dealer or directly to Invacare®.

8.4.4 Replacing the main fuse



Note

To replace the fuse, the battery cable with the fuse attached to it must be replaced.

- Replace the battery cables, as described in chapter 8.4.2.

8.4.5 Checking the cables



Requirements:

- Side cutting pliers
- Cable ties

- Remove the covers, disconnect the battery plug connections and pull the batteries out of the battery compartment, as described in chapter 8.4.1.

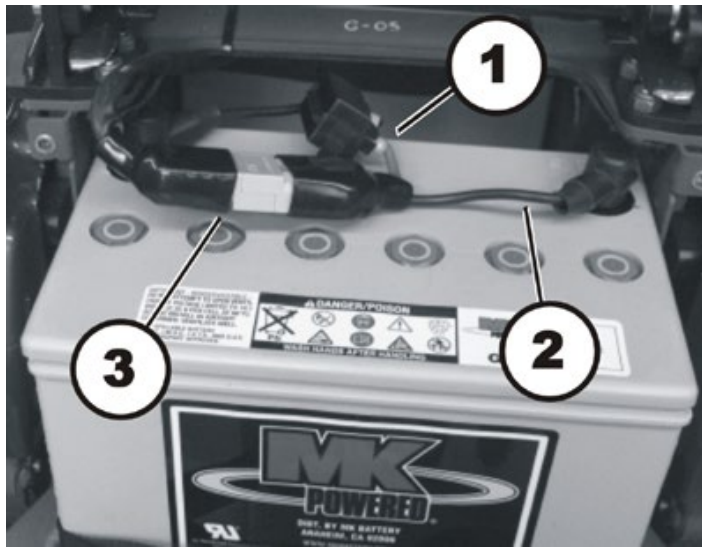

- Check the fuse cable (1), the battery cable (2) and the battery connections (3) for visible damage and pinches.
- Replace damaged cables, as described in chapter 8.4.2.



Note

The positions of the plugs are described in chapter 4.2.

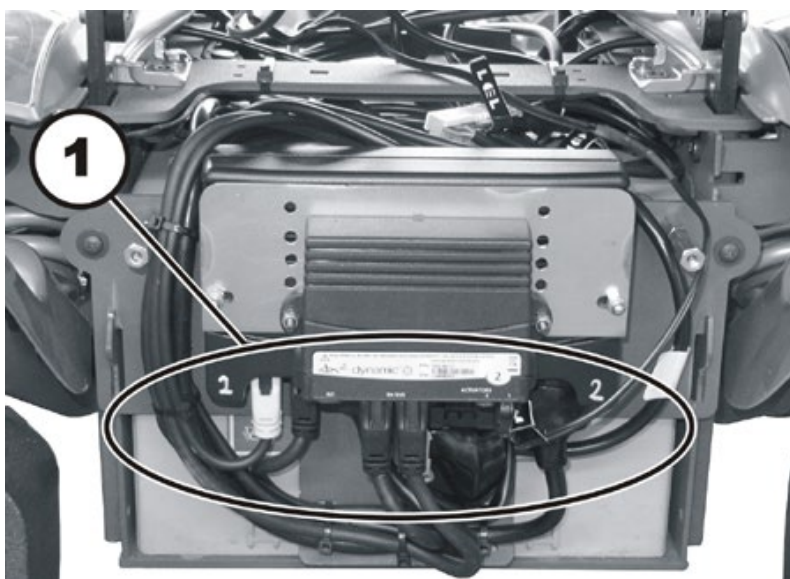

- Check all cables for visible damage and crushing. Replace damaged cables.
- Pull on each plug (1) carefully. The plug must not come out of the socket.
- If a plug is loose, apply slight pressure to push the plug into the socket. The plug must snap in place securely.
- Check whether the connector is fitted firmly. If not, repeat the previous step.
- Assemble the parts in reverse order.
- Check all functions of the vehicle and go for a test drive.

8.5 Replacing the battery boxes



Requirements:

- 7 mm socket wrench
- 8 mm socket wrench
- 10 mm socket wrench
- 13 mm socket wrench
- 16 mm socket wrench
- 22 mm socket wrench
- 13 mm open-ended wrench
- 3 mm Allen key
- 4 mm Allen key
- 5 mm Allen key
- 6 mm Allen key
- Small flat screwdriver
- Torque wrench 5 – 30 Nm (or similar)
- Torque wrench 10 – 80 Nm (or similar)
- Side cutting pliers
- Cable ties
- Two oblong wooden blocks, at least 14 x 14 x 30 cm

Uninstalling the battery box:

- Remove the drive wheels, as described in chapter 8.8.1.
- Uninstall all plastic covers, as described in chapter 8.1.
- Remove all electronic modules that are fitted in the rear on the battery box, as described in chapter 8.2.2.
- Remove the seat including the seat frame, as described in chapter 8.13 and 8.17.
- Remove the batteries, as described in chapter 8.4.1.
- If necessary, remove the conventional rear lighting system, as described in chapters 8.6.10 and 8.6.14.
- Remove the anti-tipper wheels, as described in chapter 8.10.
- Remove the motor / gearbox mounting including suspension, as described in chapter 8.12.
- Remove the fixation rings, as described in chapter 8.19.
- Replace the battery box.

Installing the battery box:

- Install the fixation rings, as described in chapter 8.19.
- Install the motor / gearbox mounting including suspension, as described in chapter 8.12.
- Install the drive wheels, as described in chapter 8.8.1.
- Install the anti-tipper wheels, as described in chapter 8.10.
- If necessary, install the conventional rear lighting system, as described in chapters 8.6.10 and 8.6.14.
- Install the batteries, as described in chapter 8.4.1.
- Install the seat including the seat frame, as described in chapter 8.13 and 8.17.
- Install all electronic modules that are fitted in the rear on the battery box, as described in chapter 8.2.2.
- Install all plastic covers, as described in chapter 8.1.
- Install the drive wheels, as described in chapter 8.8.1.
- Perform a comprehensive driving and function test with the wheelchair.

8.6 Lighting system

**Note**

There are two different lighting units. A conventional lighting unit with bulbs and a LED lighting unit.

8.6.1 Replacing light bulbs in the front (conventional lighting system)

**Requirements:**

- Phillips screwdriver size 2

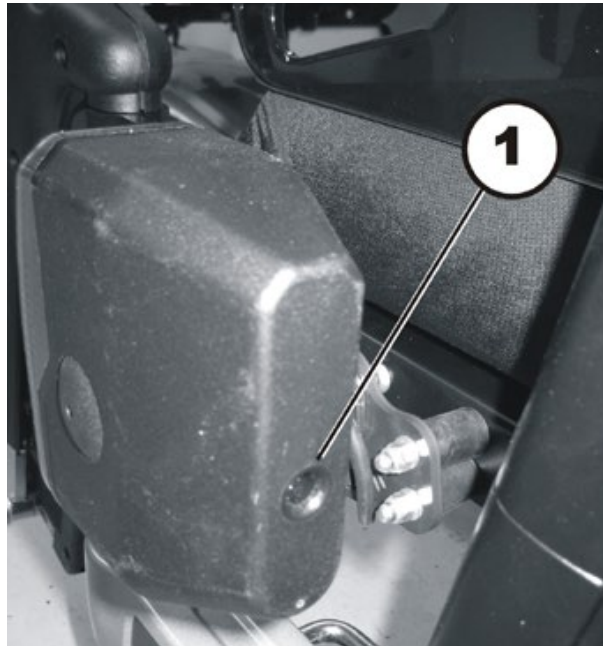

- Loosen the concealed Phillips head screw on the back of the head lamp / turn indicator combination.
- Remove the transparent plastic cover.
- Replace the defective light bulb.
- Reposition the cap and tighten the Phillips head screw hand-tight.

8.6.2 Replacing the LEDs in the front (LED lighting system)

- Individual LEDs are not intended to be replaced. Replace the complete lighting system, as described in chapter 8.6.5.

8.6.3 Replacing the complete head lamp assembly (conventional lighting system until 03/2012)

**Requirements:**

- Phillips screwdriver size 2
- Side cutting pliers
- Cable ties

Uninstalling head lamps:

- Remove the rear cover, as described in chapter 8.1.2.

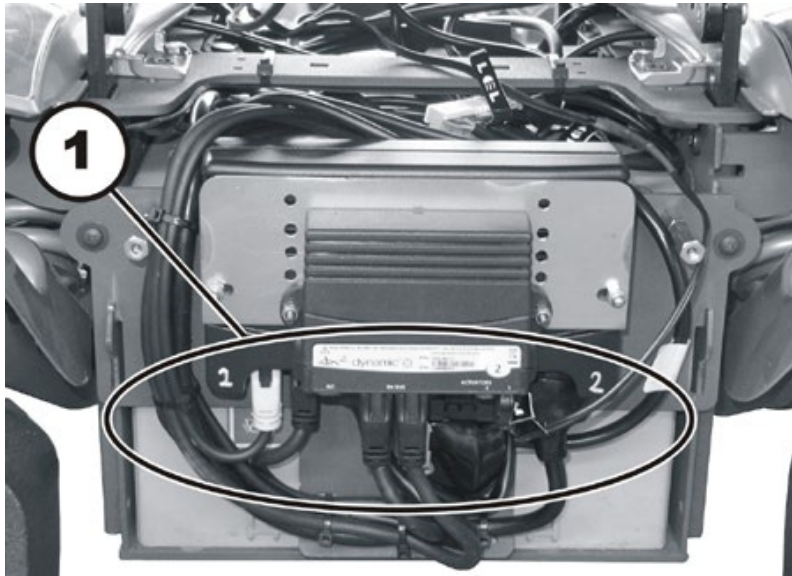

- Take exact note of the positions of all cables and the sockets (1) that they are connected to. Mark the connectors and sockets or take a photograph with a digital camera.
- Disconnect the cable of the affected head lamp from the lighting circuit board.
- Remove all cable ties and pull the cable out of the wheelchair.

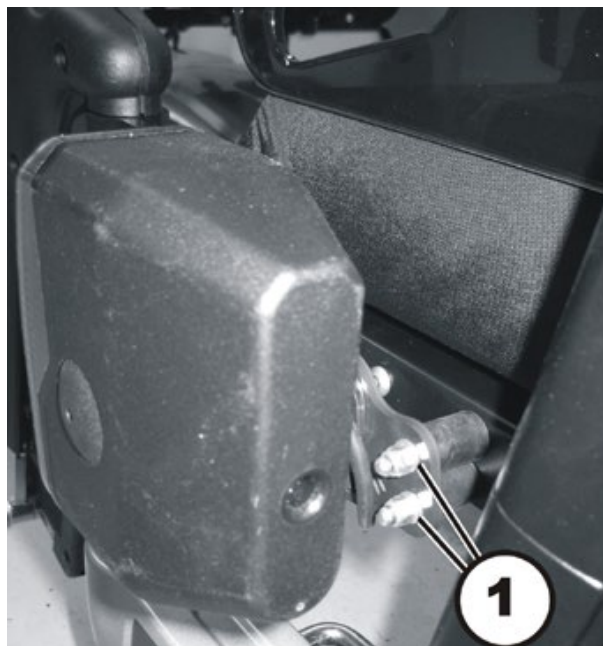

- Loosen both of the cap nuts (1) with an 8 mm open-end wrench and remove the head lamp with the bracket from the rubber mounting.
- Not shown in the illustration are two Phillips head screws, with which the head lamp is secured to the bracket. Loosen both of these Phillips head screws to remove the head lamp from the bracket.
- Replace the head lamp.

Installing head lamps:

- Assemble all parts again in reverse order.
- Install the cables carefully and secure them with cable ties. Make sure that the cables not are not pinched or stretched.
- Tighten both screws hand-tight.
- Check all vehicle functions.
- Perform an approximate adjustment of the head lamp using the ratchet plate as a guide. The final adjustment can be performed by the user according to the instructions found in the User Guide.

8.6.4 Replacing headlamps completely (conventional lighting system starting 03/2012)

**Requirements:**

- Phillips screwdriver size 2
- Open-end wrench 8 mm
- Side cutting pliers
- Cable ties

Uninstalling headlights:

- Remove the rear cover, as described in chapter 8.1.2.

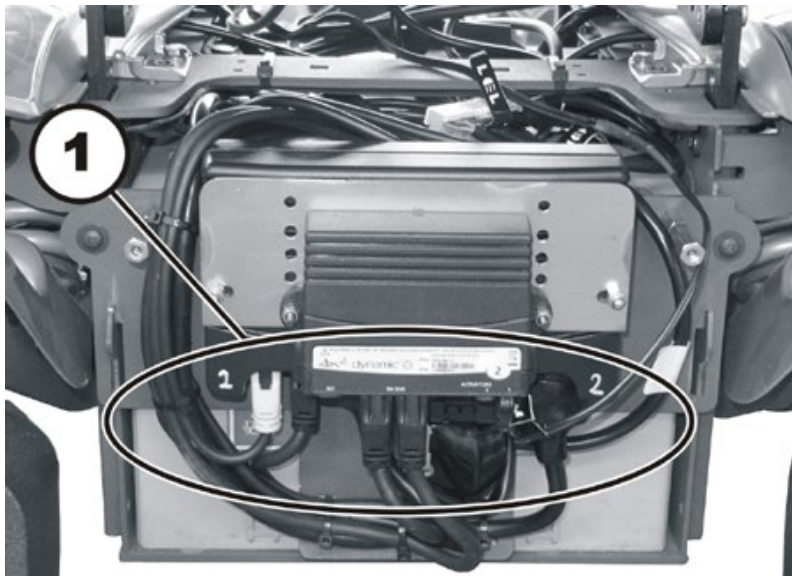

- Take exact note of the positions of all cables and the sockets that they are connected to. Mark the connectors and sockets or take a photograph with a digital camera.
- Disconnect the cable of the affected headlight from the lighting circuit board.
- Open the cable clamps (1), remove all cable ties and pull the cable out of the wheelchair.

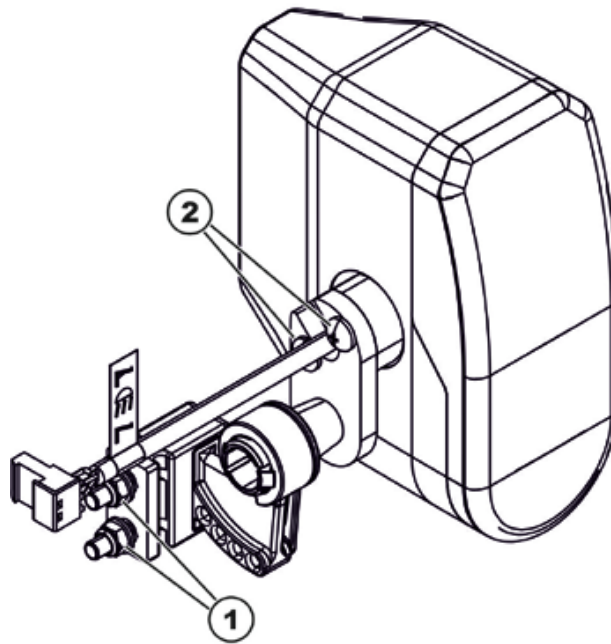

- Loosen both of the nuts (1) with an 8 mm open-end wrench and remove the headlight with the bracket from the rubber mounting.
- Loosen both Phillips head screws (2) to remove the headlight from the bracket.
- Replace the headlight.

Installing headlights:

- Assemble all parts again in reverse order.
- Install the cables carefully and secure them with the cable clamps and cable ties.
- Tighten the screws hand-tight.
- Check all vehikel functions.
- Perform an approximate adjustment of the headlight using the ratchet plate as a guide. The final adjustment can be performed by the user according to the instructions found in the User Guide.

8.6.5 Replacing the head lamps completely (LED lighting system until 03/2012)



Requirements:

- 3 mm Allen key
- Side cutting pliers
- Cable ties

Uninstalling head lamps:

- Remove the rear cover, as described in chapter 8.1.2.

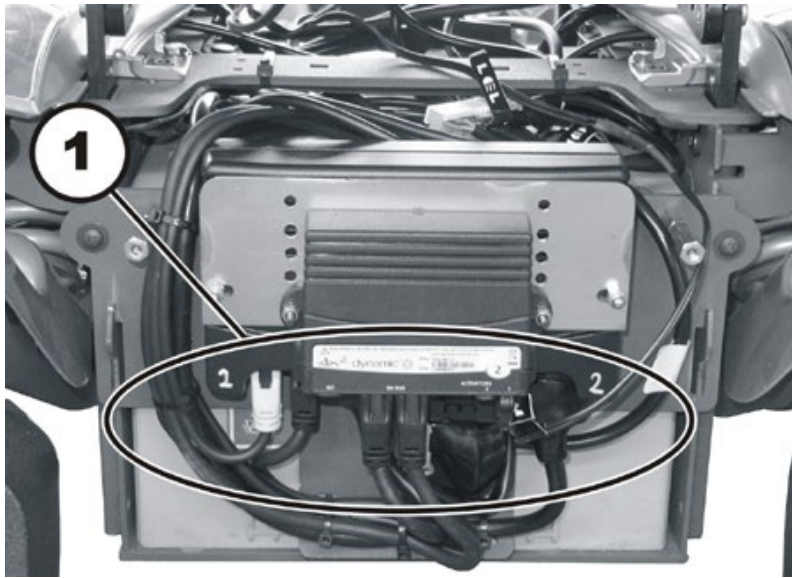

- Take exact note of the positions of all cables and the sockets (1) that they are connected to. Mark the connectors and sockets or take a photograph with a digital camera.
- Disconnect the cable of the affected head lamp from the lighting circuit board.
- Remove all cable ties and pull the cable out of the wheelchair.

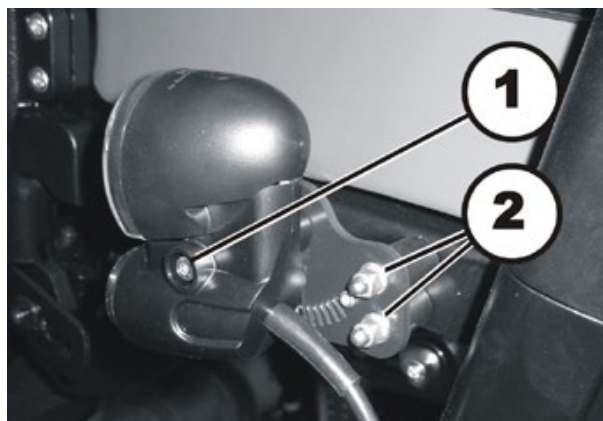

- Loosen the hexagon socket head screw (1) with a 3 mm Allen key and remove the head lamp from the bracket.
- Replace the head lamp.

Installing head lamps:

- Assemble all parts again in reverse order.
- Install the cables carefully and secure them with cable ties. Make sure that the cables not are not pinched or stretched.
- Tighten both screws hand-tight.
- Check all vehicle functions.
- Perform an approximate adjustment of the head lamp using the ratchet plate as a guide. The final adjustment can be performed by the user according to the instructions found in the User Guide.

8.6.6 Replacing headlamps completely (LED lighting system starting 03/2012)



Requirements:

- 4 mm Allen wrench
- Side cutting pliers
- Cable ties

Uninstalling headlights:

- Remove the rear cover, as described in chapter 8.1.2.

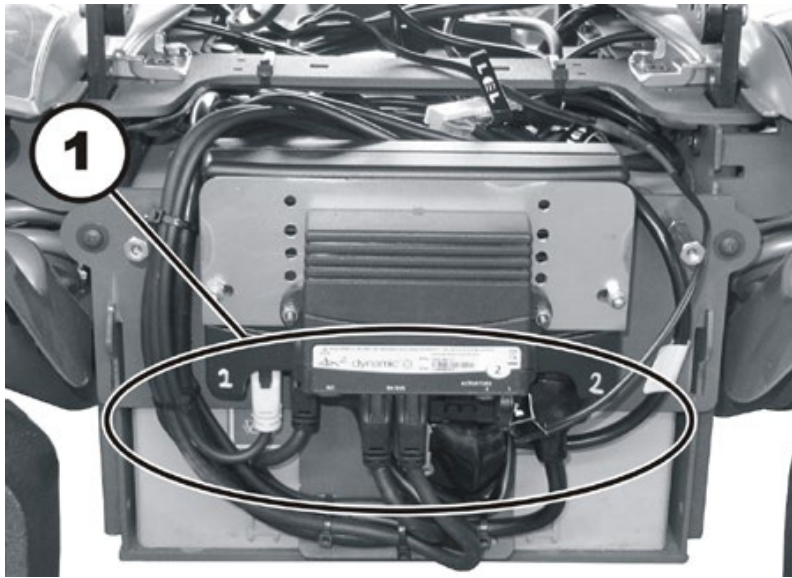

- Take exact note of the positions of all cables and the sockets that they are connected to. Mark the connectors and sockets or take a photograph with a digital camera.
- Disconnect the cable of the affected headlight from the lighting circuit board.
- Open the cable clamps (1), remove all cable ties and pull the cable out of the wheelchair.

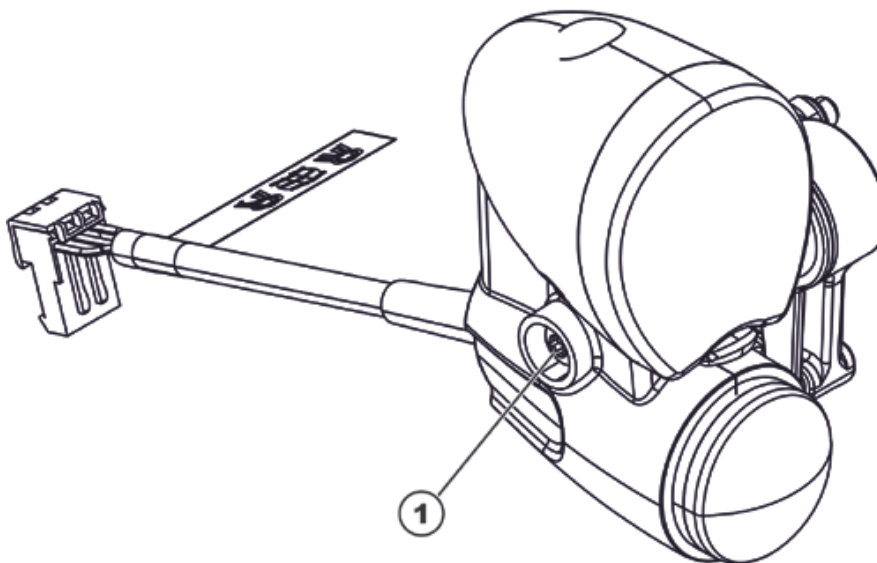

- Loosen the hexagon socket head screw (1) with a 4 mm Allen wrench and remove the headlight from the bracket.
- Replace the headlight.

Installing headlights:

- Assemble all parts again in reverse order.
- Install the cables carefully and secure them with the cable clamps and cable ties.
- Tighten the screws hand-tight.
- Check all vehicle functions.
- Perform an approximate adjustment of the headlight using the ratchet plate as a guide. The final adjustment can be performed by the user according to the instructions found in the User Guide.

8.6.7 Replacing the head lamp bracket (conventional lighting system until 03/2012)

**Requirements:**

- Phillips screwdriver size 2
- 8 mm socket wrench

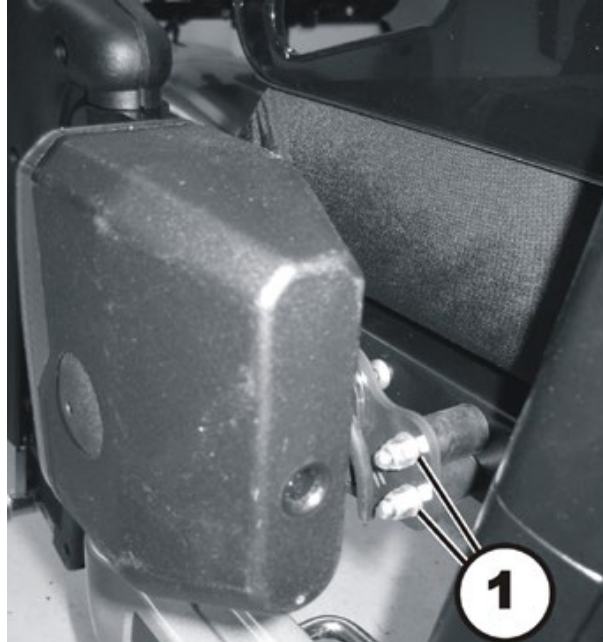
**Uninstalling the head lamp bracket:**

- Loosen both of the cap nuts (1) with an 8 mm socket wrench and remove the head lamp with the bracket from the rubber mounting.
- Not shown in the illustration are two Phillips head screws, with which the head lamp is secured to the bracket. Loosen both of these Phillips head screws to remove the head lamp from the bracket.
- Replace the bracket.

Installing the head lamp bracket:

- Assemble all parts again in reverse order.
- Tighten both screws hand-tight.
- Check all vehicle functions.
- Perform an approximate adjustment of the head lamp using the ratchet plate as a guide. The final adjustment can be performed by the user according to the instructions found in the User Guide.

8.6.8 Replacing headlamp brackets (conventional lighting system starting 03/2012)

**Requirements:**

- Phillips screwdriver size 2
- Open-end wrench 8 mm

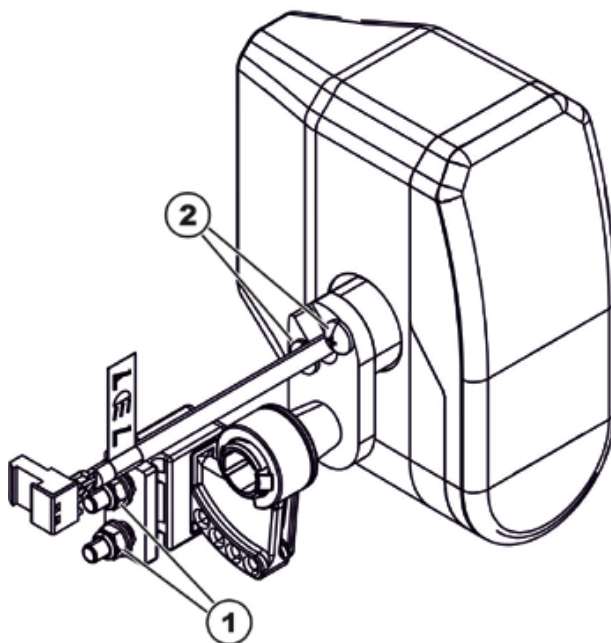
**Uninstalling the tail light bracket:**

- Loosen both of the nuts (1) with an 8 mm open-end wrench and remove the headlight with the bracket from the rubber mounting.
- Loosen both Phillips head screws (2) to remove the headlight from the bracket.
- Replace the bracket.

Installing the headlight bracket:

- Assemble all parts again in reverse order.
- Tighten the screws hand-tight.
- Check all vehicle functions.
- Perform an approximate adjustment of the headlight using the ratchet plate as a guide. The final adjustment can be performed by the user according to the instructions found in the User Guide.

8.6.9 Replacing the front bulb holder (LED lighting system until 03/2012)

**Requirements:**

- 4 mm Allen key
- 8 mm spanner

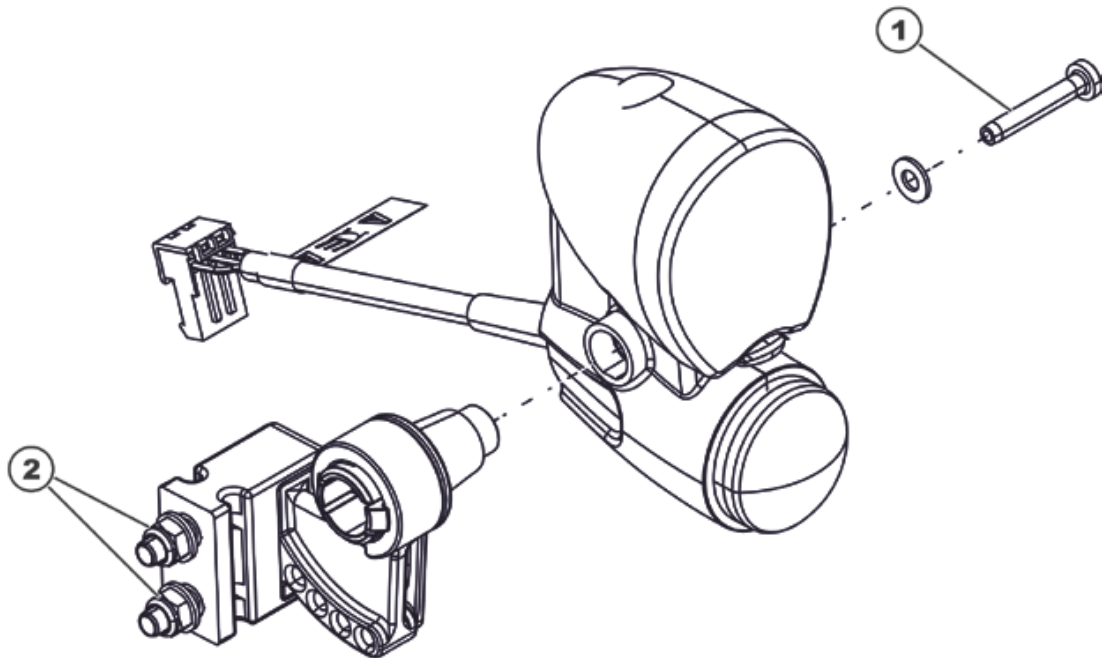
**Dismantling the bulbholder:**

- Loosen the Allen screw (1) using a 4 mm Allen key and remove the headlight from the mounting.
- Loosen the two cap nuts (2) using an 8 mm spanner and remove the headlight with the mounting from the rubber bumpers.
- Replace the mounting.

Refitting the bulbholder:

- Refit the parts in reverse order.
- Now tighten all the screws finger-tight again.
- Check all vehicle functions.
- Adjust the headlight roughly using the grid. The user can carry out the final adjustment following the operating manual.

8.6.10 Replacing a light bulb in the rear (conventional lighting system)

**Requirements:**

- Phillips screwdriver size 2



- Loosen the Phillips head screw in the transparent cover of the tail lamp / turn indicator combination.
- Remove the transparent plastic cover.
- Replace the defective light bulb.
- Reposition the cap and tighten the Phillips head screw hand-tight.

8.6.11 Replacing the LEDs in the rear (LED lighting system)

- Individual LEDs are not intended to be replaced. Replace the complete red tail lamp and/or the yellow turn indicator, as described in chapter 8.6.16.

8.6.12 Replacing the complete tail lamp assembly (conventional lighting system until 08/2014)



Requirements:

- 8 mm socket wrench

Uninstalling the tail lamp:

- Remove the front cover and the rear covers, as described in chapters 8.1.1 and 8.1.2.

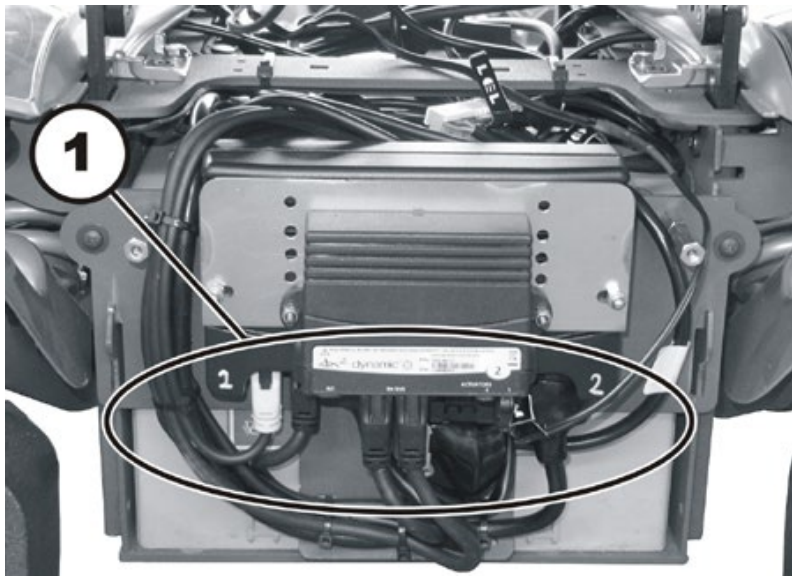

- Take exact note of the positions of all cables and the sockets (1) that they are connected to. Mark the connectors and sockets or take a photograph with a digital camera.
- Disconnect the cable of the affected tail lamp from the lighting circuit board.
- Remove all cable ties and pull the cable out of the wheelchair.

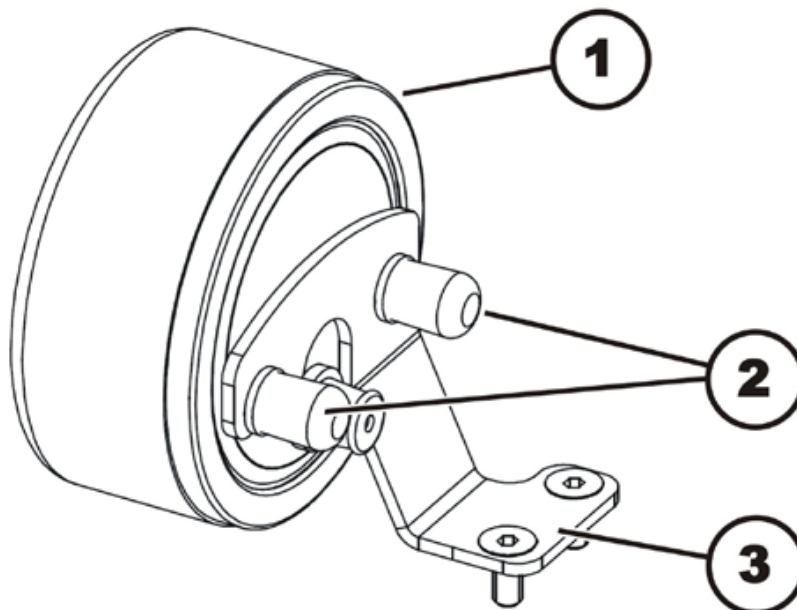

- Remove both plastic covers (2).
- Use an 8 mm socket wrench to loosen both nuts.
- Remove the nuts together with the washers.
- Pull the tail lamp (1) towards the rear and remove from the tail lamp bracket (3).

Installing the tail lamp:

- Assemble all parts again in reverse order.
- Tighten both screws hand-tight.
- Check all vehicle functions.

8.6.13 Replacing the complete tail lamp assembly (conventional lighting system starting 08/2014)



Requirements:

- 8 mm socket wrench

Uninstalling the tail lamp:

- Remove the front cover and the rear covers, as described in chapters 8.1.1 and 8.1.2.

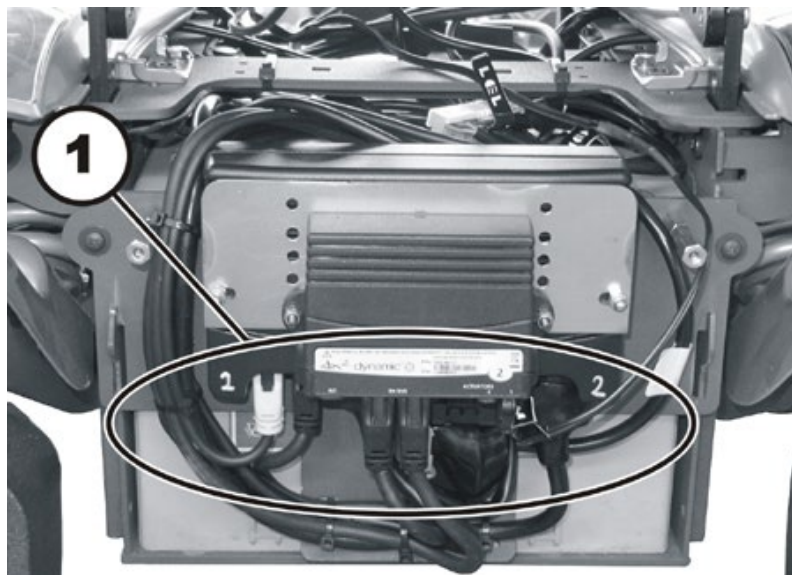

- Take exact note of the positions of all cables and the sockets (1) that they are connected to. Mark the connectors and sockets or take a photograph with a digital camera.
- Disconnect the cable of the affected tail lamp from the lighting circuit board.
- Remove all cable ties and pull the cable out of the wheelchair.

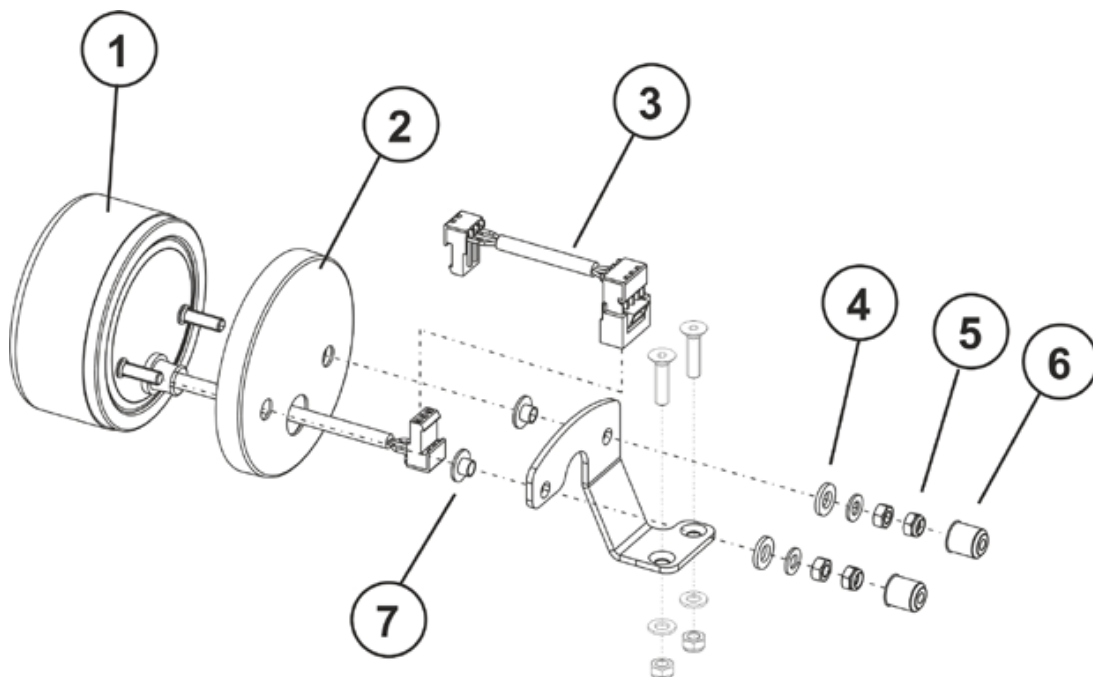

- Remove both plastic covers (6).
- Use an 8 mm socket wrench to loosen the four nuts.
- Remove the nuts together with the washers (4).
- Pull off the rear light (6) to the rear and remove both bushes (7) including the lamp protector (2).

Installing the tail lamp:

- Assemble all parts again in reverse order.
- Tighten both screws hand-tight.
- Check all vehicle functions.

8.6.14 Replacing the tail lamp bracket (conventional lighting system until 08/2014)

**Requirements:**

- 3 mm Allen key

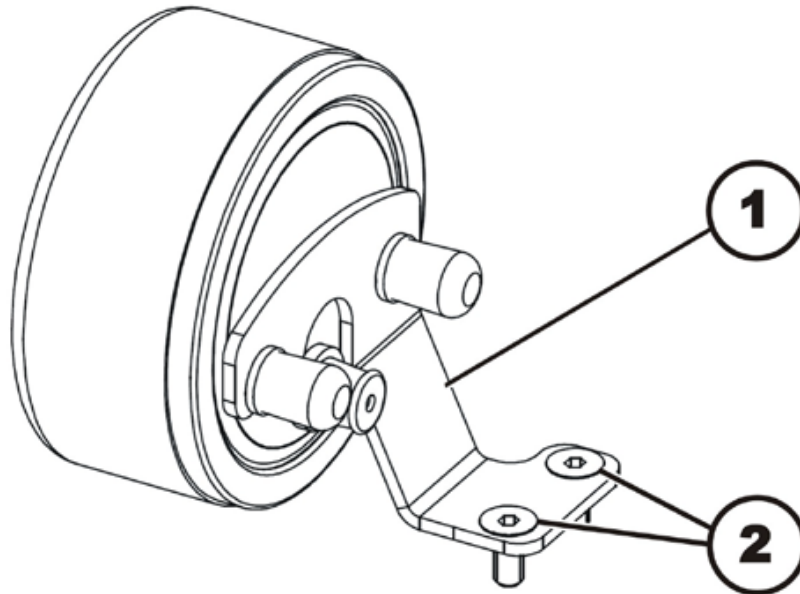
**Uninstalling the head lamp bracket:**

- Remove the front, rear and lateral covers, as described in chapter 8.1.1, 8.1.2 and 8.1.3.
- Uninstall the complete tail lamp assembly, as described in chapter 8.6.12.
- Use the 3 mm Allen key to loosen and remove both screws (2).
- Replace the lamp bracket (1).

Installing the head lamp bracket:

- Assemble all parts again in reverse order.
- Check all vehicle functions.

8.6.15 Replacing the tail lamp bracket (conventional lighting system starting 08/2014)

**Requirements:**

- 3 mm Allen key

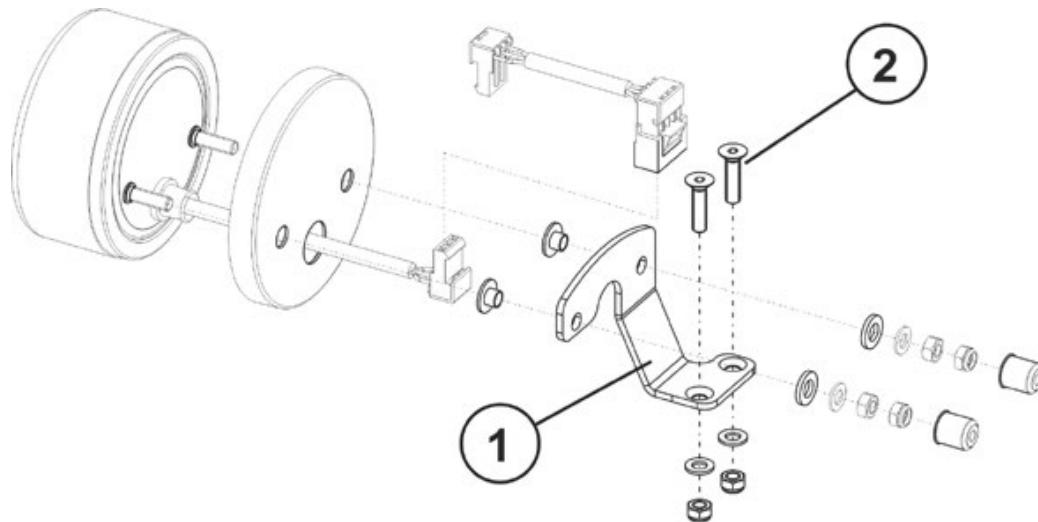
**Uninstalling the head lamp bracket:**

- Remove the front, rear and lateral covers, as described in chapter 8.1.1, 8.1.2 and 8.1.3.
- Uninstall the complete tail lamp assembly, as described in chapter 8.6.13.
- Use the 3 mm Allen key to loosen and remove both screws (2).
- Replace the lamp bracket (1).

Installing the head lamp bracket:

- Assemble all parts again in reverse order.
- Check all vehicle functions.

8.6.16 Replacing the tail lamps completely (LED lighting system)

**Note**

Individual LEDs are not intended to be replaced. The LEDs are replaced along with the complete bracket assembly. This means that the complete red or yellow tail lamp is replaced.

**Requirements:**

- Phillips screwdriver, size 1

Uninstalling the tail lamp:

- Remove the front, rear and the applicable lateral cover, as described in chapters 8.1.1, 8.1.2 and 8.1.3.

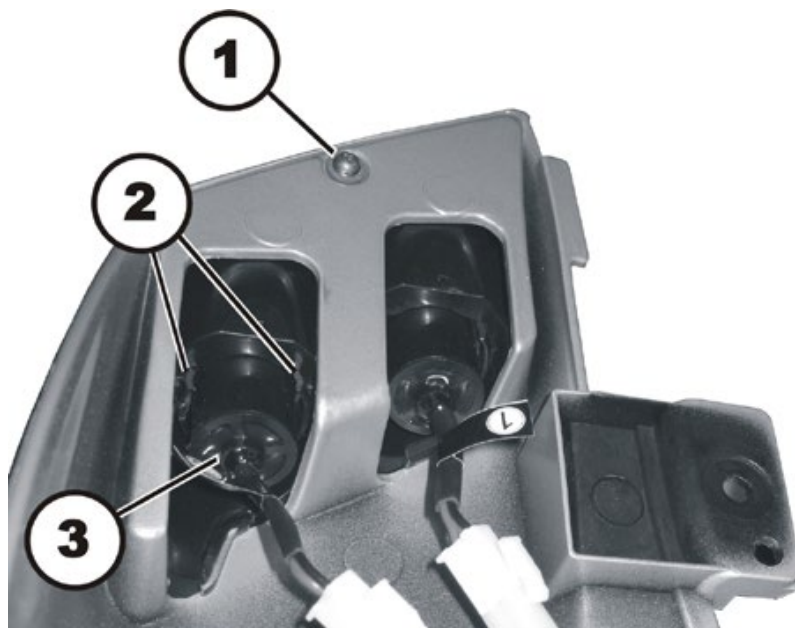

- Use a Phillips screwdriver to loosen and remove the screw (1).
- Remove the transparent cover from the top side (not visible in the illustration).
- Carefully bend both mounting brackets (2) apart.
- Push the tail lamp (3) including cable and plug out of the bracket.

Installing the tail lamp:

- Assemble all parts again in reverse order.
- Tighten both screws hand-tight.
- Check all vehicle functions.

8.7 Rear wheels

8.7.1 Replacing a rear wheel



Requirements:

- Small flat screwdriver
- 16 mm socket wrench
- Two oblong wooden blocks, at least 14 x 14 x 30 cm



WARNING: Danger of crushing!

The wheelchair is very heavy. Danger of injury to the hands and feet!

- Use proper lifting techniques.

Danger of injury due to uncontrolled movement of the wheelchair!

- Switch the vehicle's power system off (ON-/OFF key).
- Engage the drive motors.
- Secure the vehicle against rolling away by placing wedges under the wheels.

Uninstalling a rear wheel:

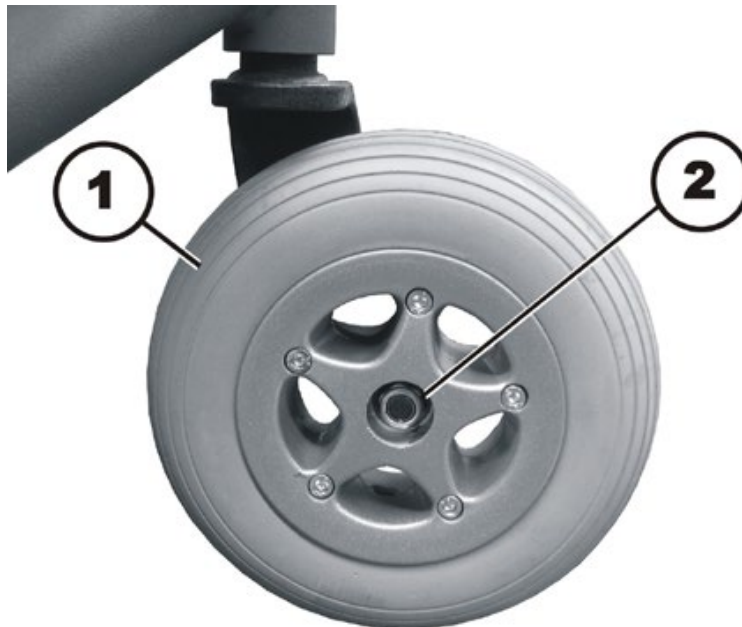

- Lift the wheelchair on one side and place a 14 cm high wooden block underneath it so that the rear wheel is off the ground and can rotate freely. Use proper lifting techniques.
- Carefully remove the black plastic cap from the middle of the anti-tipper wheel (1) with a small flat screwdriver. The cap is not shown in the above illustration.
- Use the 16 mm socket wrench to loosen the self-securing axle nut (2).
- Remove the axle nut and the washer.
- Pull the wheel off the axle.

Installing a rear wheel:

- Assemble the parts in reverse order.
- Tighten the self-securing axle nuts just tight enough that the wheel can still rotate without resistance.

8.7.2 Replacing a rear wheel fork



WARNING: Danger of crushing!

The wheelchair is very heavy. Danger of injury to the hands and feet!

- Use proper lifting techniques.

Danger of injury due to uncontrolled movement of the wheelchair!

- Switch the vehicle's power system off (ON-/OFF key).
- Engage the drive motors.
- Secure the vehicle against rolling away by placing wedges under the wheels.



Requirements:

- 22 mm socket wrench
- 4 mm Allen key
- Oblong wooden blocks, at least 14 x 14 x 30 cm

Uninstalling a wheel fork:

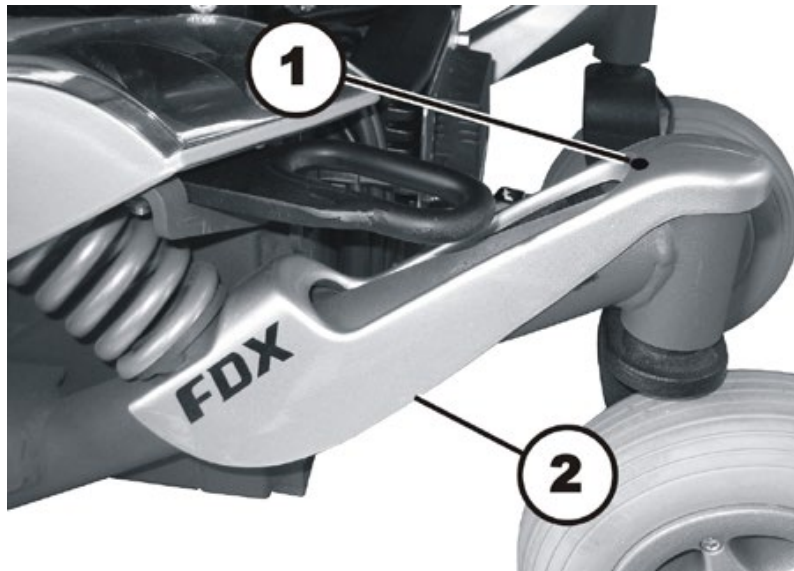

- Use the 4 mm Allen key to loosen and remove the hexagon socket head screw (1).
- Pull the cover up in the rear and remove it. The cover is held in place by additional Velcro fasteners.

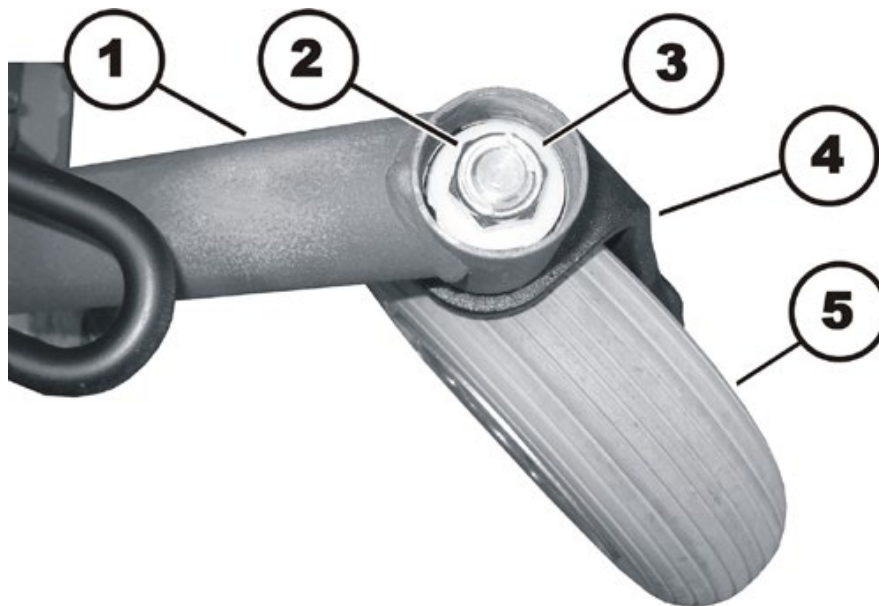

- Prop up the wheelchair on multiple wooden blocks. Use proper lifting techniques.
- Use the 22 mm socket wrench to loosen and remove the self-securing nut (2).
- Pull the wheel fork (4) downwards out of the rear wheel cantilever arm (1). Pay attention to the washers (3), spacer washers and the separable ball bearings (not visible in the illustration).

Installing a wheel fork:

- Assemble the parts in reverse order.
- When installing the ball bearings, make absolutely sure that the wide inner rings are visible on the outside.
- Adjust the wheel fork, as described in chapter 8.7.3.
- The last step is to test all functions of the vehicle.

8.7.3 Adjusting the wheel fork



WARNING: Danger of crushing!

The wheelchair is very heavy. Danger of injury to the hands and feet!

- Use proper lifting techniques.



Requirements:

- 22 mm socket wrench

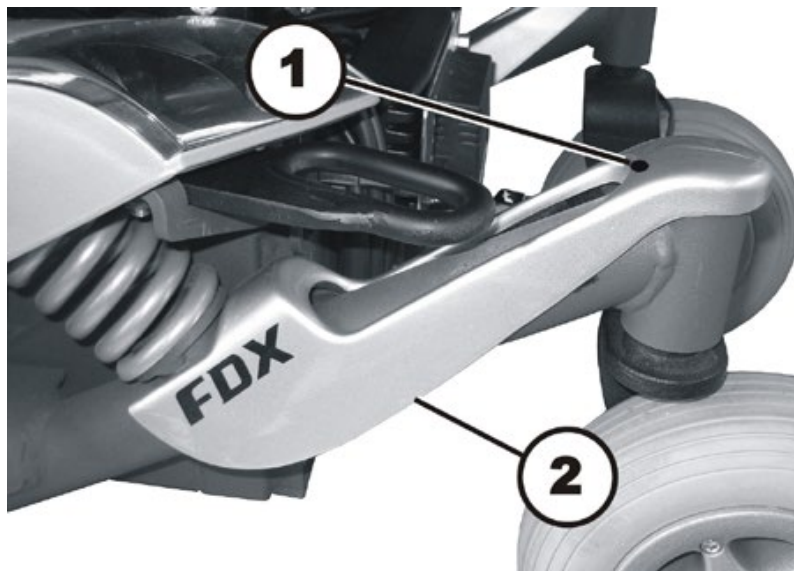

- Use the 4 mm Allen key to loosen and remove the hexagon socket head screw (1).
- Pull the cover up in the rear and remove it. The cover is held in place by additional Velcro fasteners.

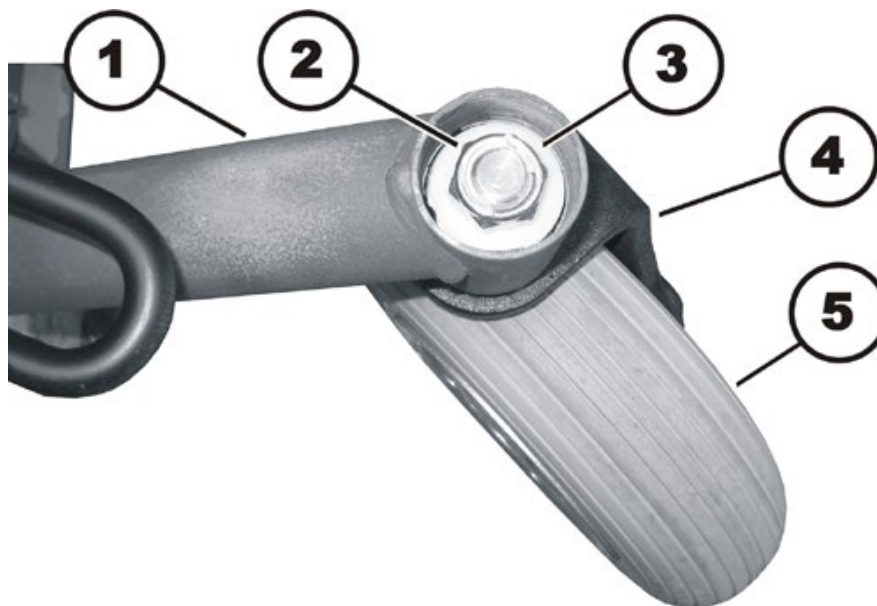

- Tilt the wheelchair forward over the drive wheels, until the anti-tipper wheels prevent it from tipping any farther. Use proper lifting techniques.
- Swivel the wheels (5) so that they point upward.
- Release the wheels, so that they can swing downwards.
- Adjust the nut (2) using a 22 mm socket wrench so that the wheel forks are not too loose, but can still rotate freely.
The wheels should swing up to the other side a maximum of one time, before coming to rest pointed downward.
- Place the wheelchair back on all of its wheels.
- Test the maneuverability of the wheelchair.
- Repeat the individual steps if necessary until the coasters are correctly adjusted.
- Install the cover again.

8.8 Drive wheels

8.8.1 Replacing a drive wheel



WARNING: Danger of crushing!

The wheelchair is very heavy. Danger of injury to the hands and feet!

- Use proper lifting techniques.

Danger of injury due to uncontrolled movement of the wheelchair!

- Switch the vehicle's power system off (ON-/OFF key).
 - Engage the drive motors.
 - Secure the vehicle against rolling away by placing wedges under the wheels.
-

**Requirements:**

- 6 mm Allen key
 - Two oblong wooden blocks, at least 14 x 14 x 30 cm
 - Torque wrench 5 – 30 Nm (or similar)
-

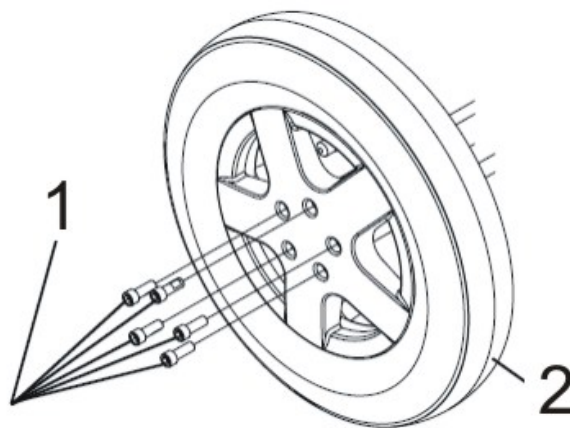
**Uninstalling a drive wheel:**

- Lift the wheelchair on one side and place a 14 cm high wooden block underneath it so that the drive wheel is off the ground and can rotate freely. Use proper lifting techniques.
- Repeat this if necessary on the other side of the wheelchair.
- Loosen the five 6 mm hexagon socket head screws (1).
- Pull the wheel (2) off the hub.

Installing a drive wheel:

- Install the wheel in reverse order.
- Tighten the screws to a torque of 25 Nm.

8.8.2 Replacing a tyre



Requirements:

- 5 mm Allen key
- Two oblong wooden blocks, at least 14 x 14 x 30 cm
- Three c-clamps with plastic caps
- Torque wrench 5 – 30 Nm (or similar)
- Talcum powder

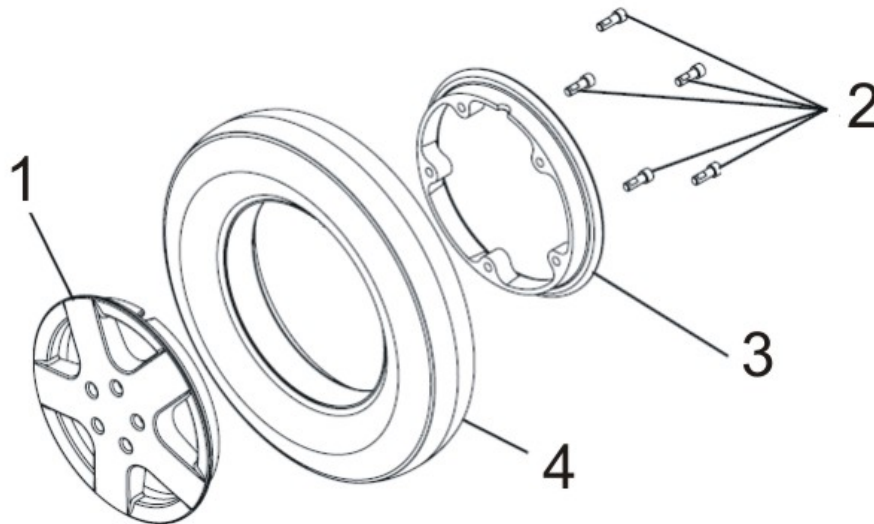

Uninstalling a tyre:

- Remove the wheel, as described in chapter 8.8.1.



CAUTION: EXPLOSION HAZARD!

The tyre is under high pressure. There is danger of injury! Parts can be projected at you causing serious injury if you do not secure the wheel rims.

- *Secure the wheel rim halves with c-clamps.*

- Secure the wheel rim halves with three c-clamps to prevent them from unintentionally popping apart. Be careful not to scratch the rims in the process.
- Loosen the five 5 mm hexagon socket head screws (2) on the inside of the wheel.
- Carefully loosen the c-clamps in small increments one after the other, until you can safely remove the rim halves.
- Remove the inner ring (3) and outer ring (1) of the rim from the tyre (4).
- Replace defective or worn out components.

Installing a tyre:

- Assemble the tyre in reverse order on the rim.
- When assembling the rim halves, make sure that the smooth and threaded holes for the screws are aligned exactly on top of each other.
- Apply the three c-clamps.
- Tighten the c-clamps in small increments one after the other until the rim halves are squarely pressed together.
- Tighten the hexagon socket head screws (2) to a torque of 25 Nm.

8.8.3 Replacing a drive wheel hub



WARNING!

Danger of damage to the wheelchair! Collisions can be caused if shim rings are removed from the drive wheels during installation work!

- Shim rings are frequently placed between the drive shaft and the wheel hub to compensate tolerances. Collisions can be caused if these shim rings are removed and not re-installed.
- Please install all shim rings in exactly the same positions they were before disassembly.



Requirements:

- 19 mm socket wrench
- Torque wrench 10 – 80 Nm (or similar)

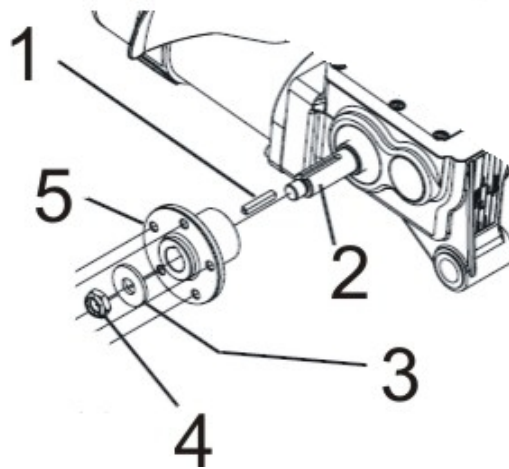

Uninstalling a drive wheel hub:

- Use the 19 mm socket wrench to loosen and remove the axle nut (4).
- Remove the washer (3).
- Pull the wheel hub (5) off of the axle (2).
- Remove the feather key (1) from the axle.

Installing a drive wheel hub:

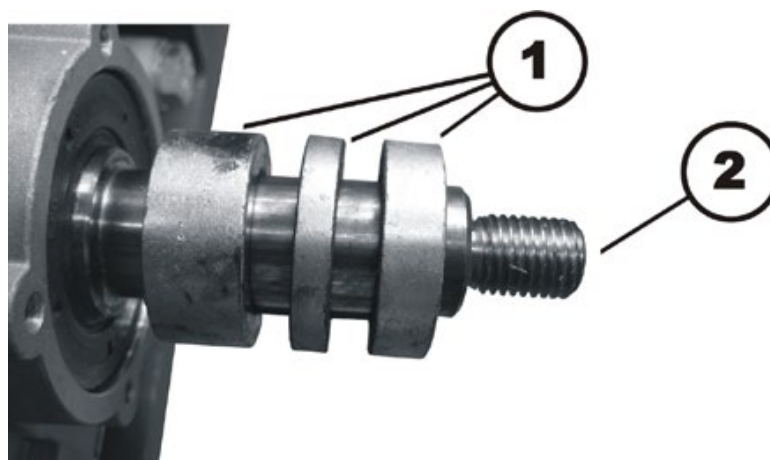

- Assemble the parts of the wheel hub in reverse order.
- Between the wheel and the motor / drive unit, distance rings of various widths are inserted to adjust the clearance between the wheel and the motor. Select the correct width for the distance rings.
- Use a thin film of lubricant to replace the wheel hub on the axle.
- Tighten the screws to a torque of 60 Nm.

8.9 Replacing the spring in the rear



Note

Invacare® recommends always replacing both springs to ensure optimum performance of the wheelchair.



WARNING: Danger of crushing!

The wheelchair is very heavy. Danger of injury to the hands and feet!

- Use proper lifting techniques.

Danger of injury due to uncontrolled movement of the wheelchair!

- Switch the vehicle's power system off (ON-/OFF key).
- Engage the drive motors.
- Secure the vehicle against rolling away by placing wedges under the wheels.



Requirements:

- 5 mm Allen key
- Two oblong wooden blocks, at least 14 x 14 x 30 cm

Uninstalling the suspension:

- Lift the wheelchair on one side and place a 14 cm high wooden block underneath the battery compartment, so that the drive wheel is off the ground and can rotate freely. Use proper lifting techniques.
- Repeat this on the other side of the wheelchair.
- Remove the drive wheel, as described in chapter 8.8.1.
- Remove the front, rear and lateral covers, as described in chapter 8.1.1, 8.1.2 and 8.1.3.
- Remove the drive wheel, as described in chapter 8.8.1.

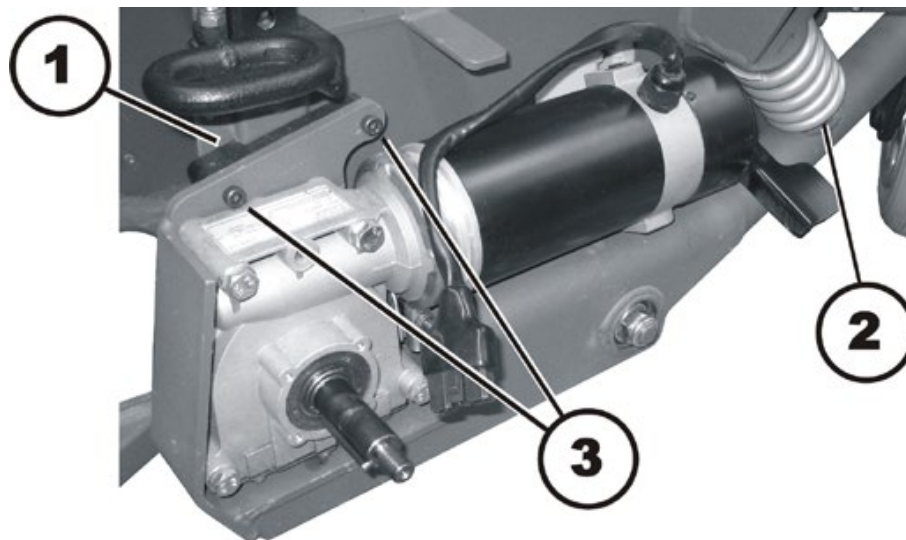

- Use the 5 mm Allen key to loosen and remove both screws (3).
- Remove the black plastic stop (1).
- Push the rear wheel cantilever arm downwards.

With a 12.5 x 2.25 inch wheel in conjunction with a hard spring, there is a shim located on top of the spring. During the next work procedure, pay attention to this shim.

- Remove the spring (2).

Installing the suspension:

- Assemble the parts in reverse order.

8.10 Replacing the anti-tipper wheels



Requirements:

- Small flat screwdriver
- Two 13 mm socket wrenches

Uninstalling an anti-tipper wheel:

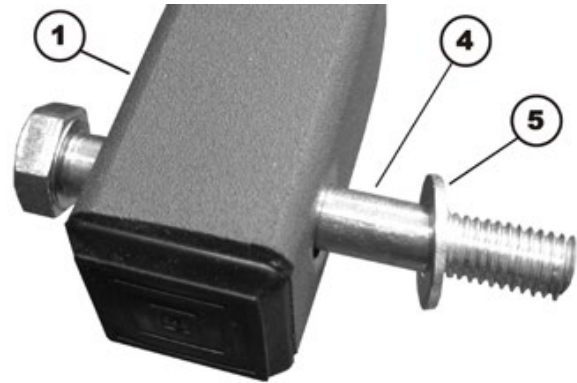
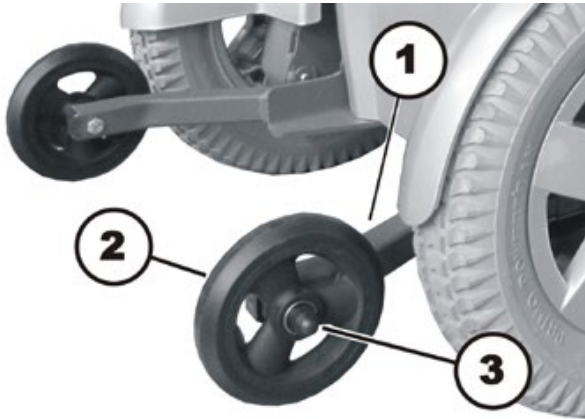

- Carefully remove the black plastic cap (3) from the middle of the anti-tipper wheel (2) with a small flat screwdriver.
- Loosen the self-securing axle nut, which is located underneath the plastic cap (not visible in the illustration) using a 13 mm socket wrench. Secure the axle (4) against slippage using a second 13 mm socket wrench.
- Remove the axle nut and the washer.
- Pull the wheel (2) off of the axle.
- Replace the wheel and/or the ball bearing.
The ball bearings are inserted in the wheel. They can be removed using a small screwdriver.

Installing an anti-tipper wheel:

- Assemble the parts in reverse order.
- When installing the ball bearings, make sure you do not forget to insert the distance sleeve between the ball bearings.
- When repositioning the wheel on the axle, make sure you do not forget the spacer washer (5).
- Tighten the self-securing axle nuts just tight enough that the wheel can still rotate without resistance. When rotated very quickly, it must not start to wobble.

8.11 Drive unit

8.11.1 Replacing the motor / gearbox unit



WARNING: Danger of crushing!

The wheelchair is very heavy. Danger of injury to the hands and feet!

- Use proper lifting techniques.

Danger of injury due to uncontrolled movement of the wheelchair!

- Switch the vehicle's power system off (ON-/OFF key).
- Engage the drive motors.
- Secure the vehicle against rolling away by placing wedges under the wheels.



Requirements:

- 5 mm Allen key
- 10 mm socket wrench
- 13 mm socket wrench
- Torque wrench 0 – 10 Nm (or similar)
- Torque wrench 5 – 30 Nm (or similar)
- Torque wrench 10 – 80 Nm (or similar)
- Two oblong wooden blocks, at least 14 x 14 x 30 cm

Uninstalling the motor / gear box unit:

- Remove the drive wheel, as described in chapter 8.8.1.
- Remove the front, rear and lateral covers, as described in chapter 8.1.1, 8.1.2 and 8.1.3.
- Disconnect the motor cable plug.
- Remove the wheel hub, as described in chapter 8.8.3.

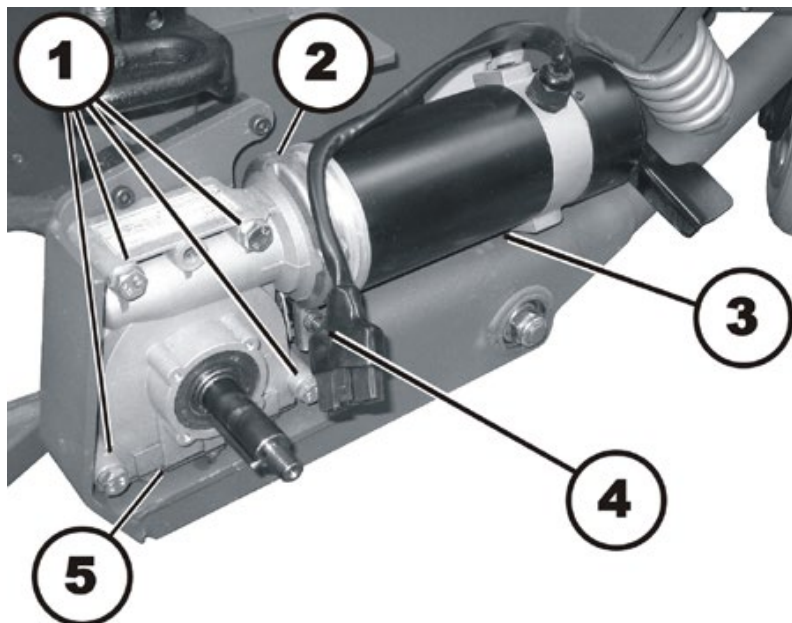

CAUTION: Danger of crushing!

The motor / gearbox unit is very heavy. Danger of injury to the hands!

- Pay attention to the heavy weight.

- Use the 13 mm socket wrench to loosen the four screws (1).
- Hold the motor / gearbox unit with one hand.
- Completely remove the four screws, including the washers.
- Remove the motor / gearbox unit.

Installing the motor / gearbox unit:

- Replace the defective components.
- Before installing a new motor / gearbox unit, make sure the sealing ring (2) is correctly mounted. The sealing ring securely attaches the motor (3) and the gearbox (5). The ring must be installed such that the self-locking nut (4) is located on the outside.
- If the sealing ring is incorrectly installed, rotate it around as described in chapter 8.11.2.
- Refit the motor/transmission unit in reverse order.
- Use the scale to align the motor to the centre axis (1)
2-pole motors and 4-pole motors:
 - Left: 0°
 - Right: 0°
- Make sure that the motor cable cannot be pinched or bent, and that it is not exposed to chafing in any place.
- To conclude, you should always carry out a trial run to test the vehicle functions.

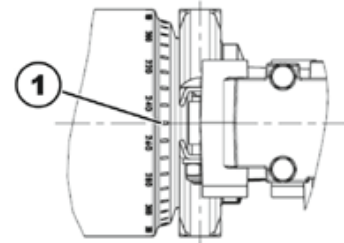

8.11.2 Replacing or rotating the motor / gearbox unit sealing ring



CAUTION: Danger of crushing!

The motor / gearbox unit is very heavy. Danger of injury to the hands!

- *Pay attention to the heavy weight.*



Requirements:

- 10 mm socket wrench

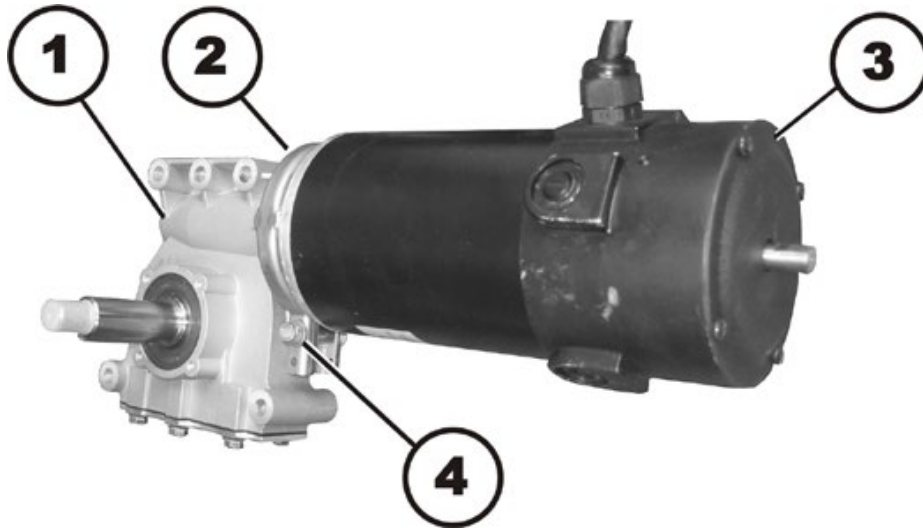

Uninstalling the sealing ring:

- Uninstall the motor / gearbox unit, as described in chapter 8.11.1.
- Use the 10 mm socket wrench to loosen and remove the self-securing nuts (4) including the washers.
- Remove the carriage bolt, which secures the sealing ring (2).
- Carefully bend the sealing ring apart and remove it.

Installing the sealing ring:

- Install the sealing ring so that the square hole for the carriage bolt is on the inside of the wheelchair.
- Insert the carriage bolt through the sealing ring.
- Install the washer and the self-locking nut.
- Do not tighten the self-locking nut completely, as the motor orientation must be adjusted during installation.

8.11.3 Replacing the motor / gearbox coupling



CAUTION: Danger of crushing!

The motor / gearbox unit is very heavy. Danger of injury to the hands!

- *Pay attention to the heavy weight.*



Requirements:

- 10 mm socket wrench

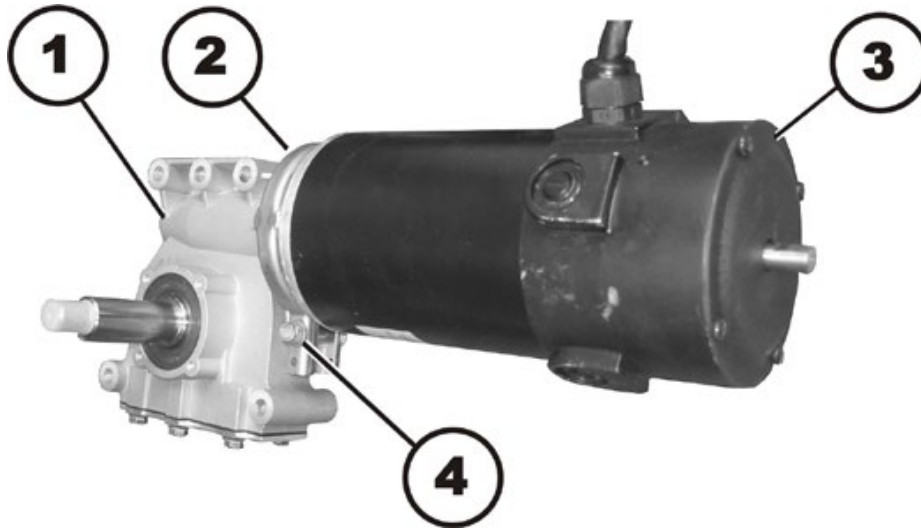

Uninstalling the motor / gearbox coupling:

- Uninstall the motor / gearbox unit, as described in chapter 8.11.1.
- Use the 10 mm socket wrench to loosen and remove the self-securing nut (4).
- Remove the carriage bolt, which secures the sealing ring (2).
- Carefully bend the sealing ring apart and remove it.



WARNING!

Danger of damage to the wheelchair if the coupling is not serviced correctly.

- *Be careful not to damage the coupling mechanism during maintenance work.*

- Carefully pull the motor (3) and the gearbox (1) apart.
- Remove the component parts of the coupling.
- If necessary replace the coupling.

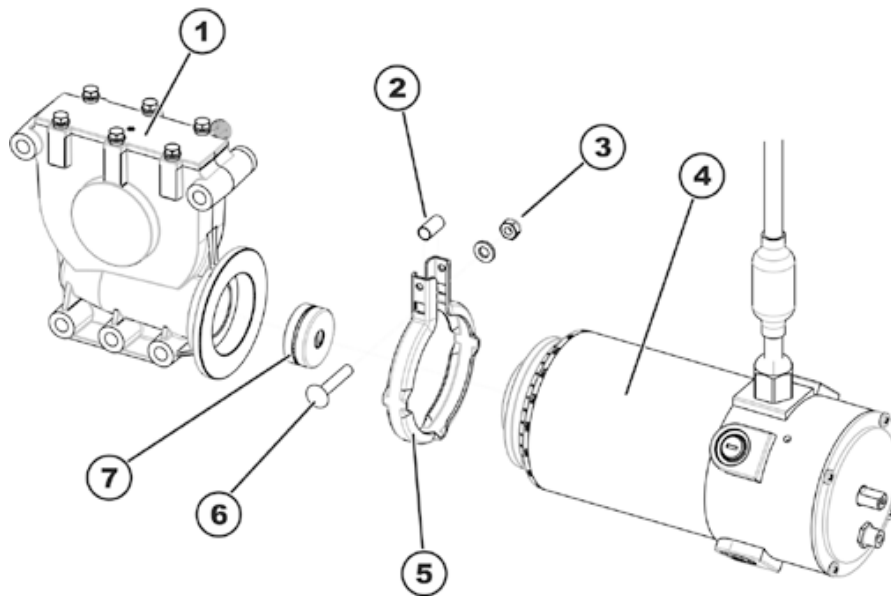
Installing the motor / gearbox coupling:

- Place the new clutch (7) on the motor axle. Pay attention to the position of the groove.
- Position the locking ring (5) on the motor (4) or the gearbox (1).
- Carefully insert the motor into the gearbox. Pay attention to the position of the groove in the axle of the gearbox. If necessary, rotate the motor and gearbox in the same position as before assembly.
- Insert the carriage bolt through the locking ring. Do not forget the spacer sleeve (2)!
- Install the washer and the self-locking nut.
- Do not tighten the self-locking nut completely, as the motor orientation must be adjusted during installation.
- Install the motor / gearbox unit, as described in chapter 8.11.1.

8.11.4 Replacing the carbon brushes

Note

Always replace all carbon brushes on both motors at the same time.

WARNING: Danger of crushing!

The wheelchair is very heavy. Danger of injury to the hands and feet!

- Use proper lifting techniques.

Requirements:

- Flat screwdriver
- 10 mm socket wrench
- Torque wrench 5 – 30 Nm (or similar)
- Two oblong wooden blocks, at least 14 x 14 x 30 cm

Uninstalling carbon brushes:

- Switch the wheelchair off.
- Remove the drive wheels, as described in chapter 8.8.1.

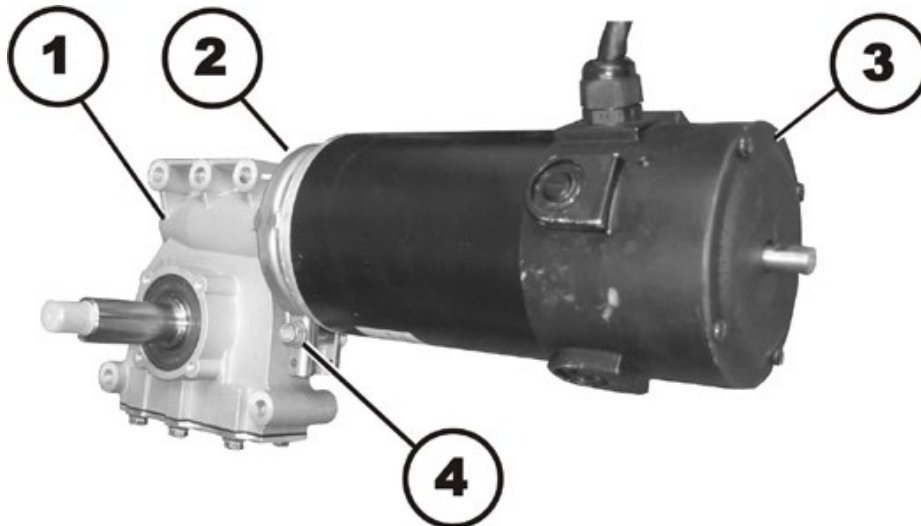

- Disconnect the motor (3) by setting the clutch lever or the clutch rotary knob (from 08/2014) to "push".
- Loosen and remove the self-locking nut (4) of the retaining ring (2) with a 10 mm socket wrench, so that the motor (3) can be rotated against the gearbox (1). This way the carbon brushes are easier to access.

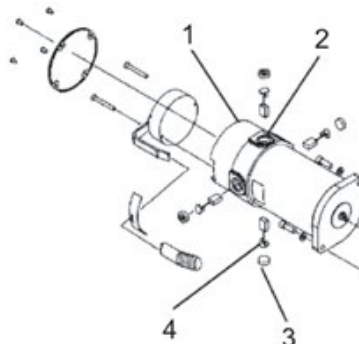

- Loosen all four plastic caps (3) with a flat screwdriver and remove the caps.
- Pull the carbon brushes (4) out of their holders slightly. Take note of the installation position and orientation of the carbon brushes.



Note

If the carbon brushes are just to be checked and not replaced, then you must take note of the position and orientation of the brushes. Used carbon brushes must be reinstalled in exactly the same position and orientation as they are in before, to ensure optimum contact with the collector.

- Mark the motor and the carbon brush to ensure correct installation.
- Completely remove the carbon brush from the socket (2).
- Check the carbon brush and the tension spring for wear, broken pieces and discolouration.

Installing carbon brushes:

- Depending on the condition of the carbon brush and the tension spring:
 - Reinstall the same carbon brush exactly as it was before, or
 - Install a new carbon brush.
- Reposition the plastic caps and tighten them.
- Turn the motor into position so that the clutch lever or clutch rotary knob (from 08/2014) can be set either to the "push" or "drive" position.
- Now retighten the bolt fingertight.
- Install the drive wheels, as described in chapter 8.8.1.
- Run the motor in, as described in chapter 8.11.6.

8.11.5 Fitting the clutch rotary knob (SSD motor)



Note

When replacing the clutch rotary knob, you must ensure that the correct fitting position is used during assembly.



Requirements:

- 3 mm Allen key

- Screw the shim on to the grub screw.
- Place the screw joint in the rotary knob (rear side (1)).

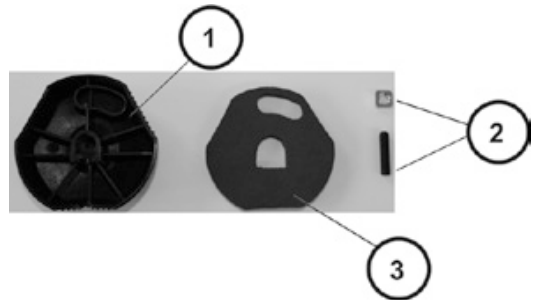

- Check to ensure that the screw joint (4) is positioned precisely in the rotary knob.
- Place the nonwoven fabric (3) in the rotary knob (rear side (1)).

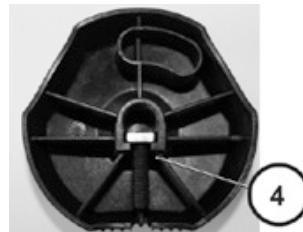

- When installing the rotary knob (5) ensure that the position (6) is correct.

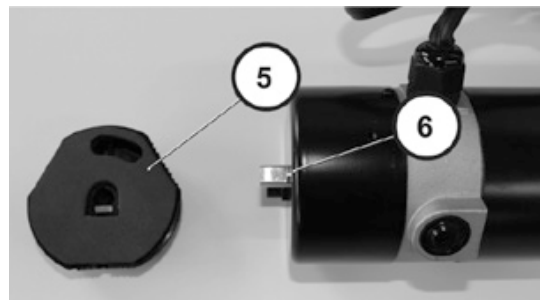

- Tighten the bolt using a 3 mm Allen key.



- Checked to ensure that the clutch rotary knob can be turned to the "push" position (downloads) and "drive" (upwards).

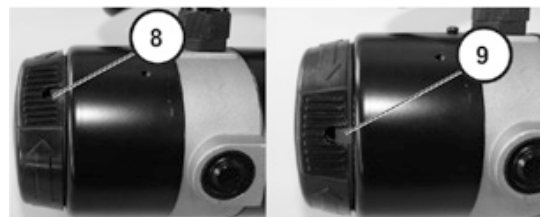

8.11.6 Running the motor in

**Note**

The following procedure is necessary to run in the motor after replacing the carbon brushes to guarantee maximum performance.

**WARNING: Danger of accidents!****Danger to people, the surroundings and wheelchair!**

- *Never leave the wheelchair unattended during the following procedure!*
- *Make sure that BOTH drive wheels are raised and CANNOT touch the ground.*
- *Secure the surrounding area.*

**Requirements:**

- Two oblong wooden blocks, at least 14 x 14 x 30 cm
-
- Lift the wheelchair on one side and place a 14 cm high wooden block underneath it so that the drive wheel is off the ground and can rotate freely. Use proper lifting techniques.
 - Repeat this on the other side of the wheelchair.
 - Allow the motors to run for an hour in the forward direction.
 - Allow the motors to cool off for 30 minutes.
 - Allow the motors to run for an hour in the backward direction.
 - Lift the wheelchair off of the wooden blocks.

8.12 Replacing the motor / gearbox fixation and rear wheel cantilever arm



WARNING: Danger of crushing!

The wheelchair is very heavy. Danger of injury to the hands and feet!

- Use proper lifting techniques.

Danger of injury due to uncontrolled movement of the wheelchair!

- Switch the vehicle's power system off (ON-/OFF key).
- Engage the drive motors.
- Secure the vehicle against rolling away by placing wedges under the wheels!



Requirements:

- 22 mm socket wrench
- 5 mm Allen key
- Torque wrench 20 – 80 Nm (or similar)
- Two oblong wooden blocks, at least 14 x 14 x 30 cm

Dismantling the motor / gearbox fixation and rear wheel cantilever arm:

- Lift the wheelchair on one side and place a 14 cm high wooden block underneath the battery compartment, so that the wheels are off the ground and can rotate freely. Use proper lifting techniques.
- Repeat this on the other side of the wheelchair.
- Remove the drive wheel, as described in chapter 8.8.1.
- Remove the front, rear and lateral covers, as described in chapter 8.1.1, 8.1.2 and 8.1.3.
- Remove the drive wheel, as described in chapter 8.8.1.

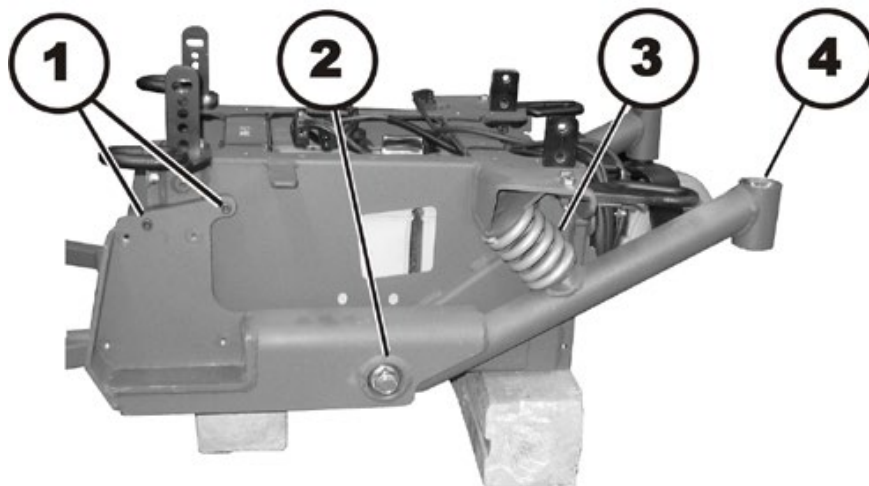

- Use the 5 mm Allen key to loosen and remove both screws (1).
- Remove the black plastic stop that is held by the screws.
- Push the rear wheel cantilever arm (4) downwards.
- Remove the spring (3).

- Use the 22 mm socket wrench to loosen and remove the self-securing nut (2).
- Remove the washer.
- Pull the motor / gearbox fixation and rear wheel cantilever arm off of the pivot point.

Assembling the motor / gearbox fixation and rear wheel cantilever arm:

- Assemble the parts in reverse order.
- Tighten the self-locking nut (2) hand-tight and check the whole assembly moves freely.

8.13 Seat adjustment standard

8.13.1 Seat / seat frame (without lifter)



Note

This chapter describes how to replace the seat frame on a wheelchair without a lifter or tilt module. To replace a lifter or tilt module, please follow the procedures explained in chapter 8.13.2.



WARNING: Danger of crushing!

The seat is very heavy. Danger of injury to hands and feet!

- Use proper lifting techniques.



Requirements:

- 6 mm Allen key
- Torque wrench 5 – 30 Nm (or similar)
- Protractor
- Side cutting pliers
- Cable ties
- Wooden block



Note

Take careful note of the exact position of the seat. Mark the position it is mounted in, the angle and so on. If necessary, make photographs with a digital camera.

Any modification of the adjustment of the seat affects the centre of gravity of the wheelchair.

Removing the seat:

- Switch the wheelchair off.
- Remove the front cover and the rear covers, as described in chapters 8.1.1 and 8.1.2.

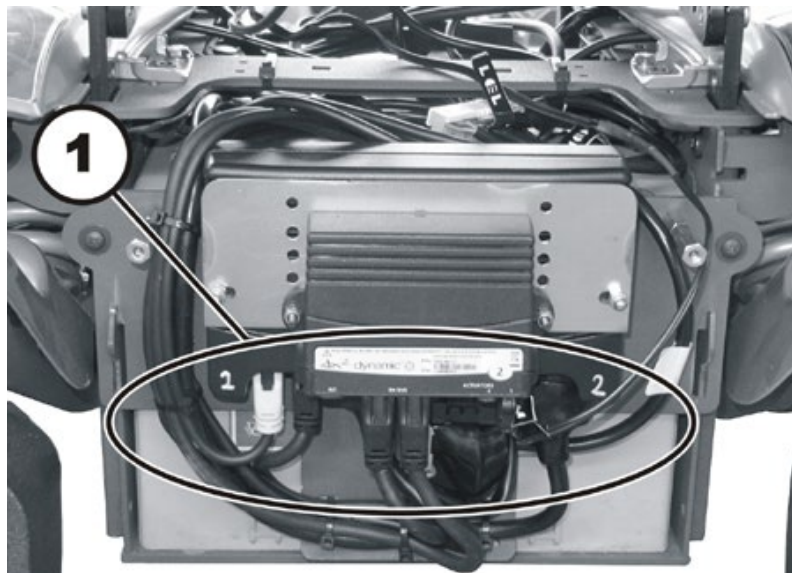

- Take exact note of the positions of all cables and the sockets (1) that they are connected to. Mark the connectors and sockets or take a photograph with a digital camera.
- Detach all cables from the electronic modules which run from the seat to the chassis.
- Place the cables so that they do not get in the way when you remove the seat.

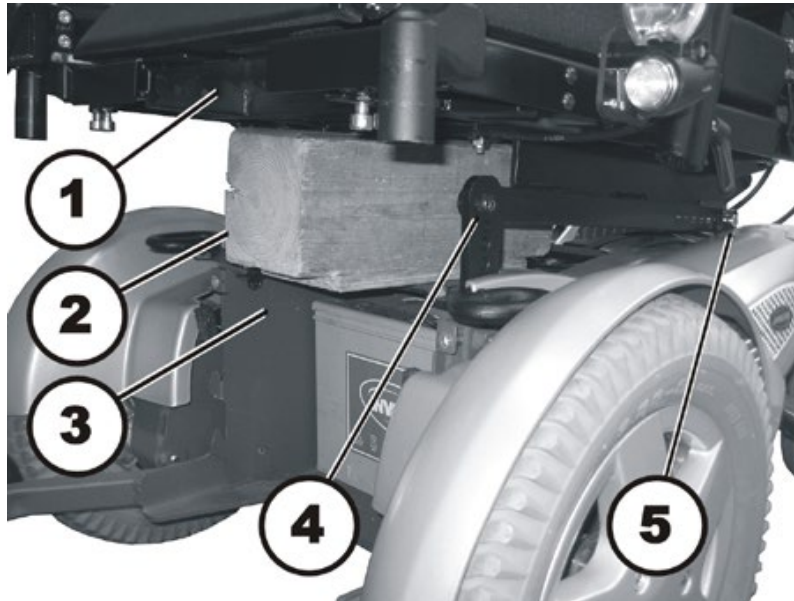

- Insert a suitable wooden block (2) between the seat (1) and the chassis (3). This will prevent the seat from falling down when you loosen and remove the screws.



WARNING: Danger of crushing!

The seat is very heavy. Danger of injury to hands and feet!

- *Use proper lifting techniques.*

-
- Use the 6 mm Allen key to loosen and remove the screws (4) on both sides in the front at the same time.
 - Hold the seat securely and loosen the rear hexagon socket head screw (5) on both sides with a 6 mm Allen key at the same time.
 - Lift the seat off.

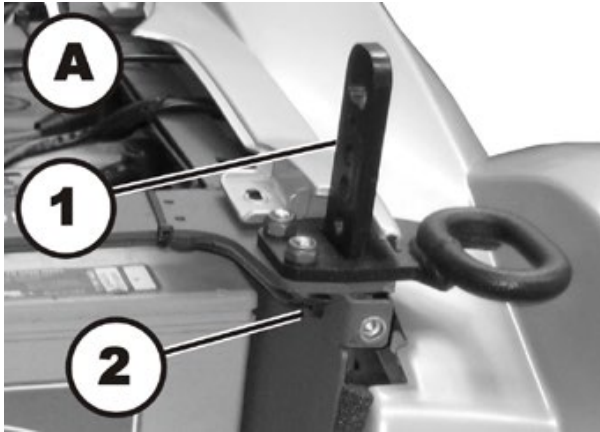
Uninstalling the seat frame:

A – front seat frame

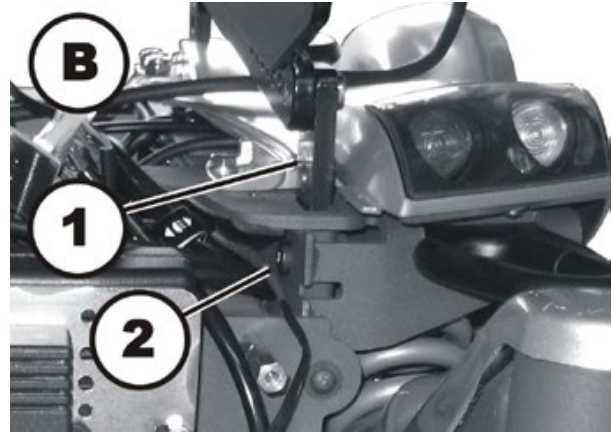

B – rear seat frame

- Use a 6 mm Allen key to loosen the hexagon socket head screws (2).
- Pull the seat frame (1) up and off.

Installing the seat and seat frame:

- Assemble all parts in reverse order.
- When installing the seat, pay attention to its heavy weight!
- When installing the seat, pay attention to the adjustment settings of the seat tilt.
- Tighten the screws to a torque of 25 Nm.
- Check all functions of the vehicle and go for a test drive.

8.13.2 Replacing the tilt module / lifter module

8.13.2.1 Replacing the tilt module (without lifter)



Note

This chapter describes how to replace the tilt module on a wheelchair without a lifter. Similar tasks are described in the following chapters:

- Replacing the seat frame alone – chapter 8.13.1
- Replacing a lifter / tilt module – chapter 8.13.2.2
- Replacing just the tilt actuator – chapter 8.13.2.3
- Replacing just the lifter actuator – chapter 8.13.2.4



WARNING: Danger of crushing!

The seat is very heavy. Danger of injury to hands and feet!

- Use proper lifting techniques.



Requirements:

- 13 mm open-ended wrench
- 4 mm Allen key
- 6 mm Allen key
- Side cutting pliers
- Cable ties



Note

Take careful note of the exact position of the seat. Mark the position it is mounted in, the angle and so on. If necessary, make photographs with a digital camera.

Any modification of the adjustment of the seat affects the centre of gravity of the wheelchair.

Uninstalling the tilt module:

- If possible, tip the wheelchair with the tilt module as far backwards as it will go.
- Switch the electronic control system off.

The actuator module for the lifter and the tilt actuator are mounted to the front edge of the seat frame.

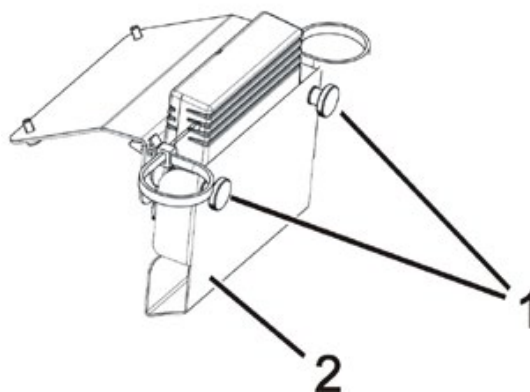

- Completely remove both knurled head screws (1) including the washers.
- Remove the cover (2).
- Disconnect the plug from the actuator module.
- Open the cable clips on the underside of the seat.
- Free up all cables so that you can lift the seat off.

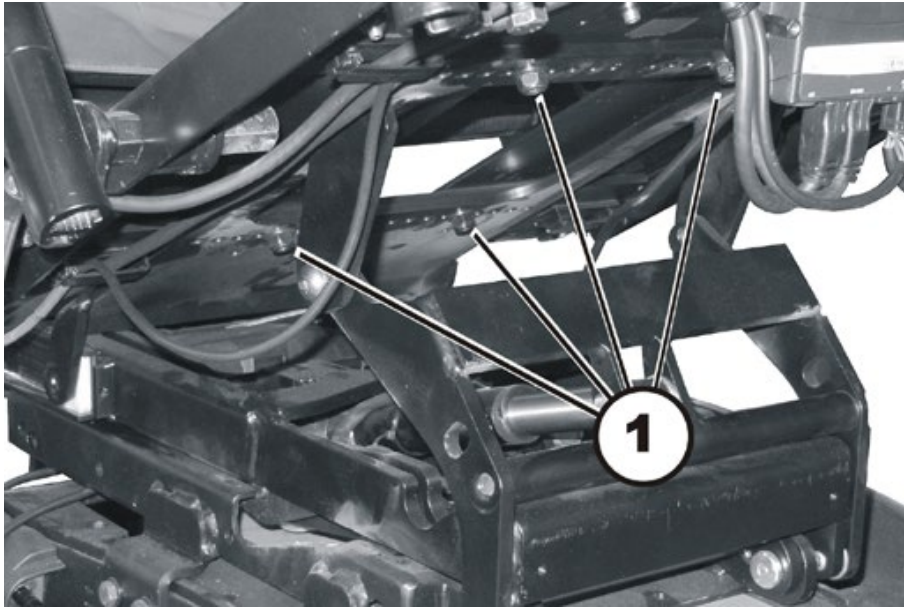

WARNING: Danger of crushing!

The seat is very heavy. Danger of injury to hands and feet!

- *Use proper lifting techniques.*
-
- Loosen the four screws (1) that attach the seat to the tilt module using a 4 mm Allen key and a 13 mm open-end wrench.
 - Lift the seat up off of the lifter module / tilt module. Use proper lifting techniques.

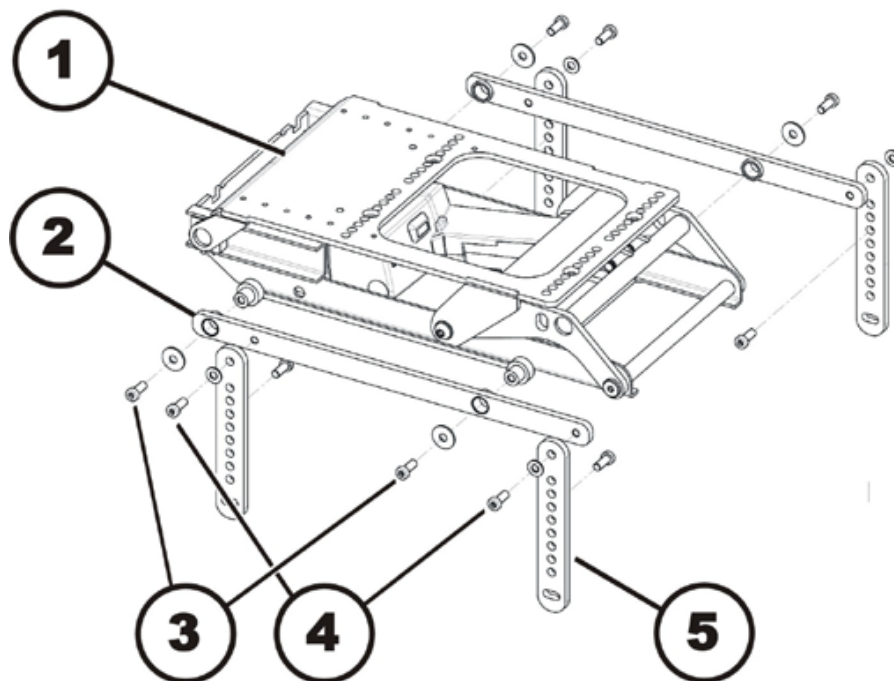

- Use the 6 mm Allen key to loosen and remove the four hexagon socket head screws (3) on both sides of the wheelchair.
- Remove the screws and the washers.
- Lift the tilt module (1) up off of its brackets (2).
- If one of the seat tilt mounting brackets (2) are to be replaced:
Use the 6 mm Allen key to loosen both screws (4) on the corresponding side of the wheelchair.
 - Remove the screws and the washers.
 - Remove the tilt mounting bracket.
- If one of the seat frame mounting brackets (5) are to be replaced:
 - Disassemble the seat frame mounting brackets as described in chapter 8.13.1 starting from the section header "Uninstalling the seat frame ".

Installing the tilt module:

- Install the tilt module in reverse order. Make sure that seat tilt mounting brackets (2) are affixed with screws to the top holes in the seat frame brackets (5).
- Tighten the connecting screws of the seat tilt mounting brackets and the seat frame mounting brackets to 18 Nm.
- When installing the cables again, make sure that they are placed in such a way that they cannot be crushed or damaged in any position of the tilt module.



WARNING: Danger of crushing!

The seat is very heavy. Danger of injury to hands and feet!

- Use proper lifting techniques.

- Install the seat.
- Install all covers again.
- Check all functions of the vehicle and go for a test drive.

8.13.2.2 Replacing the lifter / tilt module

**Note**

This chapter describes how to replace the seat frame on a wheelchair with a lifter / tilt module.

Similar tasks are described in the following chapters:

- Replacing the seat frame alone – chapter 8.13.1
- Replacing a tilt module – chapter 8.13.2.1
- Replacing just the tilt actuator – chapter 8.13.2.3
- Replacing just the lifter actuator – chapter 8.13.2.4

**WARNING: Danger of crushing!**

The seat is very heavy. Danger of injury to hands and feet!

- Use proper lifting techniques.

**Requirements:**

- 13 mm open-ended wrench
- 4 mm Allen key
- 6 mm Allen key
- 6 mm wrench
- Side cutting pliers
- Cable ties

**Note**

Take careful note of the exact position of the seat. Mark the position it is mounted in, the angle and so on. If necessary, make photographs with a digital camera.

Any modification of the adjustment of the seat affects the centre of gravity of the wheelchair.

Uninstalling the lifter / tilt module:

- If possible, raise the lifter to the highest position.
- If possible, tip the wheelchair with the tilt module as far backwards as it will go.
- Switch the electronic control system off.

The actuator module for the lifter and the tilt actuator are mounted to the front edge of the seat frame.

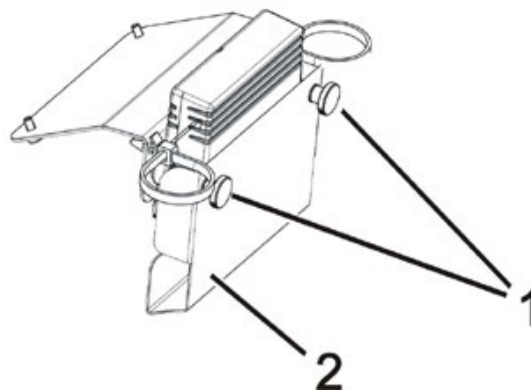

- Completely remove both knurled head screws (1) including the washers.
- Remove the cover (2).
- Disconnect the plug from the actuator module.
- Open the cable clips on the underside of the seat.
- Free up all cables so that you can lift the seat off.

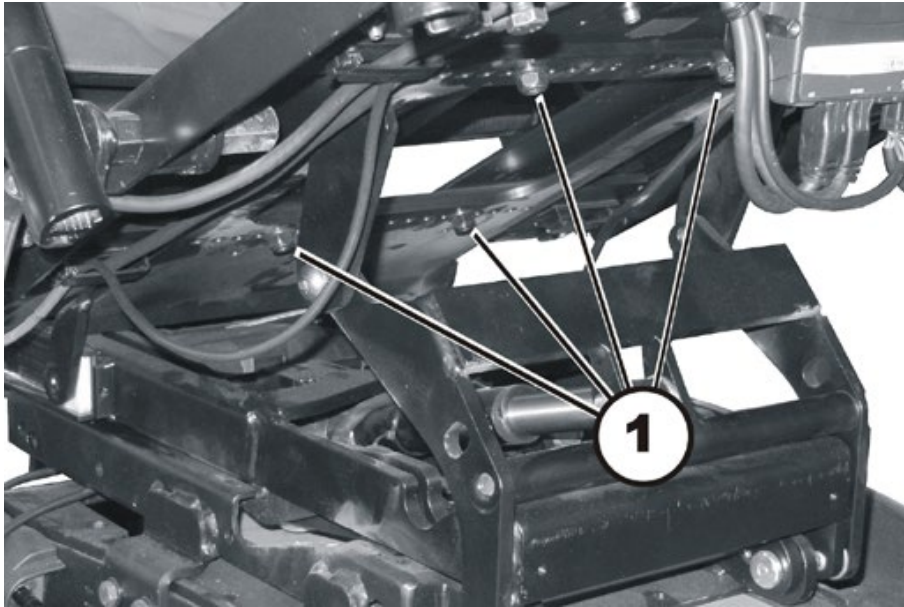

WARNING: Danger of crushing!

The seat is very heavy. Danger of injury to hands and feet!

- *Use proper lifting techniques.*

- Loosen the four screws (1) that attach the seat to the lifter / tilt module using a 4 mm Allen key and a 13 mm open-end wrench.
- Lift the seat up off of the lifter module / tilt module. Use proper lifting techniques.



- Open the power supply chain of the lifter:
 - Flip the cover (1) up.
 - Pull the flap (2) out of the cover.
 - Repeat this procedure link by link.
- Remove both cable ties that secure the cable at the ends of the power supply chain.
- Pull the cable out of the power supply chain.

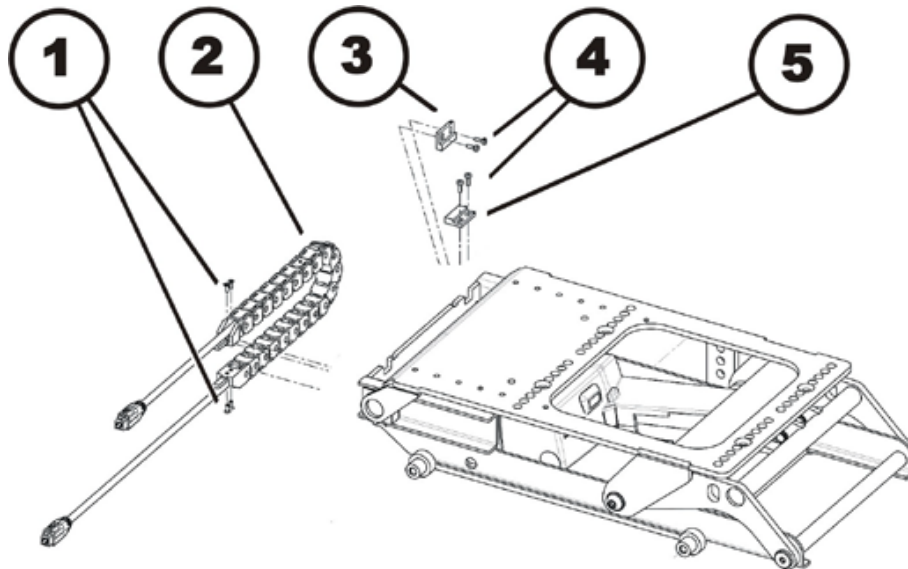

- Use the Phillips screwdriver to loosen the screws (1).
- Remove the power supply chain (2).
- Use the Phillips screwdriver to loosen the screws (4).
- Additionally the sensor (5) is secured with nuts. Loosen the nuts by holding against a 6 mm wrench.
- Remove the magnet (3).
- Remove the sensor (5).

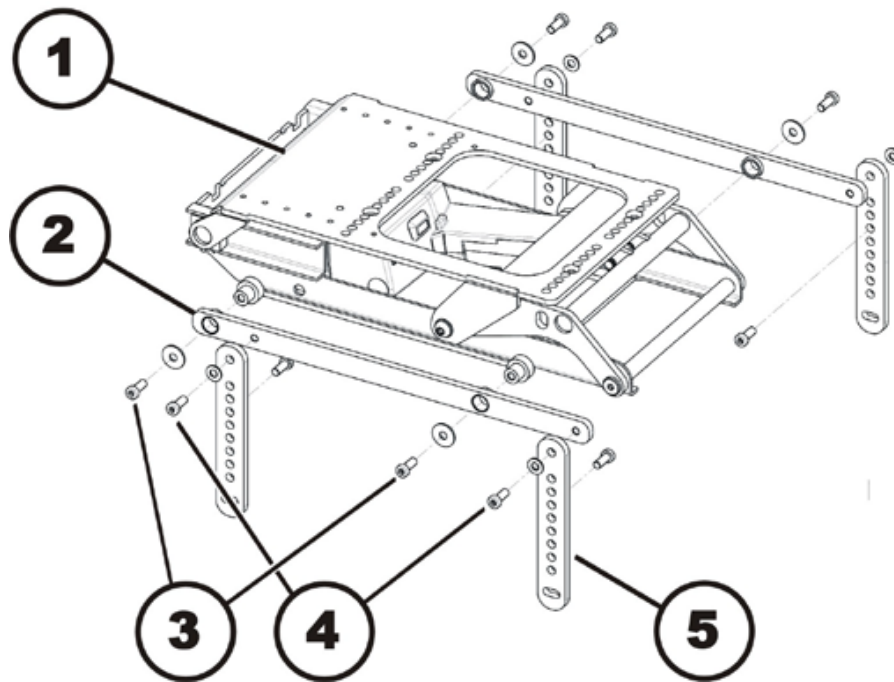

- Use the 6 mm Allen key to loosen and remove the four hexagon socket head screws (3) on both sides of the wheelchair.
- Remove the screws and the washers.
- Lift the tilt module (1) up off of its brackets (2).
- If one of the seat tilt mounting brackets (2) are to be replaced:
Use the 6 mm Allen key to loosen both screws (4) on the corresponding side of the wheelchair.
 - Remove the screws and the washers.
 - Remove the tilt mounting bracket.
- If one of the seat frame mounting brackets (5) are to be replaced:
- Disassemble the seat frame mounting brackets as described in chapter 8.13.1 starting from the section header "Uninstalling the seat frame ".

Installing the tilt module:

- Install the tilt module in reverse order. Make sure that seat tilt mounting brackets (2) are affixed with screws to the top holes in the seat frame brackets (5).
- Tighten the connecting screws of the seat tilt mounting brackets and the seat frame mounting brackets to 18 Nm.
- When installing the cables again, make sure that they are placed in such a way that they cannot be crushed or damaged in any position of the tilt module.



WARNING: Danger of crushing!

The seat is very heavy. Danger of injury to hands and feet!

- *Use proper lifting techniques.*

- Install the seat.
- Install all covers again.
- Check all functions of the vehicle and go for a test drive.

8.13.2.3 Replacing the tilt actuator

**Note**

This chapter only describes how to replace the tilt actuator.
To replace the complete tilt module, please proceed as described in chapters 8.13.2.1 and 8.13.2.2.

**WARNING: Danger of crushing!**

The seat is very heavy. Danger of injury to the hands if the seat falls down unintentionally!

- Use proper lifting techniques.
- Carefully secure the seat before removing the actuator.

**Requirements:**

- Spring-ring pliers
- Side cutting pliers
- Cable ties

**Note**

Take careful note of the exact position of the seat. Mark the position it is mounted in, the angle, the positions of all cables and so on. If necessary, make photographs with a digital camera. Any modification of the adjustment of the seat affects the centre of gravity of the wheelchair.

Uninstalling the tilt actuator:

- If possible, raise the lifter to the highest position.
- If possible, tip the wheelchair with the tilt module as far backwards as it will go.
- Switch the electronic control system off.

The actuator module for the lifter and the tilt actuator are mounted to the front edge of the seat frame.

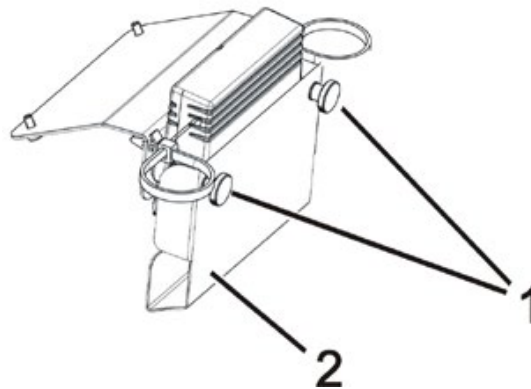

- Completely remove both knurled head screws (1) including the washers.
- Remove the cover (2).
- Disconnect the plug from the actuator module.
- Open the cable clips on the underside of the seat.
- Free up the actuator cable so it can be removed from the tilt module later along with the actuator.



WARNING: Danger of crushing!

The seat is very heavy. Danger of injury to the hands if the seat falls down unintentionally!

- Use proper lifting techniques.

- Carefully secure the seat against falling down unintentionally before removing the actuator. If there is no means to secure the seat from falling down, remove it entirely.
- In a combined lifter / tilt module, the tilt actuator is located in the upper part of the module.

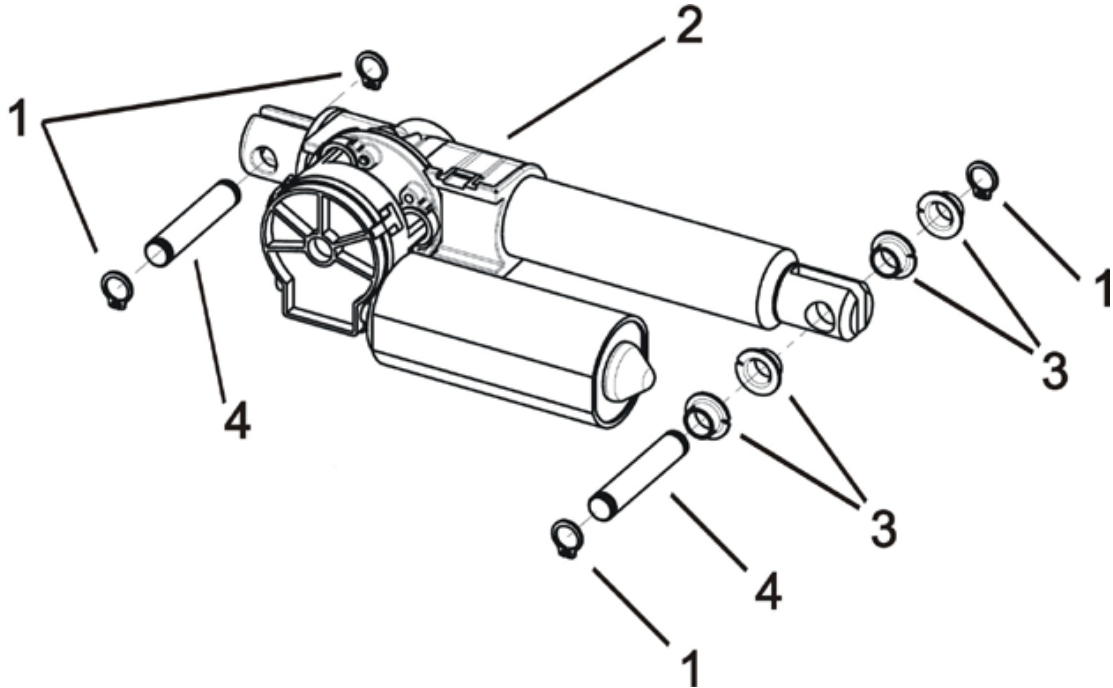

- Remove the retaining rings (1) with a pair of spring-ring pliers.
- Push the bolts (4) out of the guides. Pay attention to the bushings (3) on the front bolt.
- Remove the actuator from the tilt module.

Installing the tilt actuator:

- Assemble all parts in reverse order.
- Perform a function test.

8.13.2.4 Replacing the lifter actuator



Note

This chapter only describes how to replace the lifter actuator. To replace the complete lifter module, please follow the procedures explained in chapter 8.13.2.2.

Possible methods:

The lifter actuator is very easy to replace when the lifter is in a raised position. It is a little more complicated to replace when the lifter is in a lowered position and cannot be raised due to a fault. The individual work steps for both methods are described hereafter.

- To replace the raised lifter, please follow the procedures explained in section header "Method 1 - uninstalling the lifter actuator with the lifter raised".
- To replace the lowered lifter, please follow the procedures explained in section header "Method 2 - uninstalling the lifter actuator with the lifter lowered".

Method 1 - uninstalling the lifter actuator with the lifter raised



WARNING: Danger of crushing!

The seat is very heavy. Danger of injury to the hands if the seat falls down unintentionally!

- Use proper lifting techniques.
- Carefully secure the seat before removing the actuator.



Requirements:

- Spring-ring pliers
- Side cutting pliers
- Cable ties



Note

Take careful note of the exact position of the seat. Mark the position it is mounted in, the angle, the positions of all cables and so on. If necessary, make photographs with a digital camera. Any modification of the adjustment of the seat affects the centre of gravity of the wheelchair.

- If possible, raise the lifter to the highest position.
- If possible, tip the wheelchair with the tilt module as far backwards as it will go.
- Switch the electronic control system off.

The actuator module for the lifter and the tilt actuator are mounted to the front edge of the seat frame.

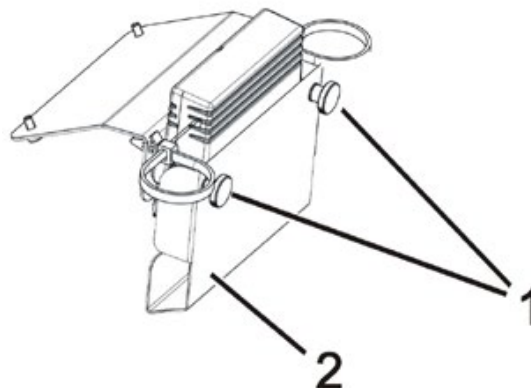

- Completely remove both knurled head screws (1) including the washers.
- Remove the cover (2).
- Disconnect the plug from the actuator module.
- Open the cable clips on the underside of the seat.
- Free up the actuator cable so it can be removed from the lifter module later along with the actuator.



WARNING: Danger of crushing!

The seat is very heavy. Danger of injury to the hands if the seat falls down unintentionally!

- *Use proper lifting techniques.*

- Carefully secure the seat against closing or falling down unintentionally before removing the actuator.
If there is no means to secure the seat from falling down, remove it entirely.
- In a combined lifter / tilt module, the lifter actuator is located in the lower part of the module.

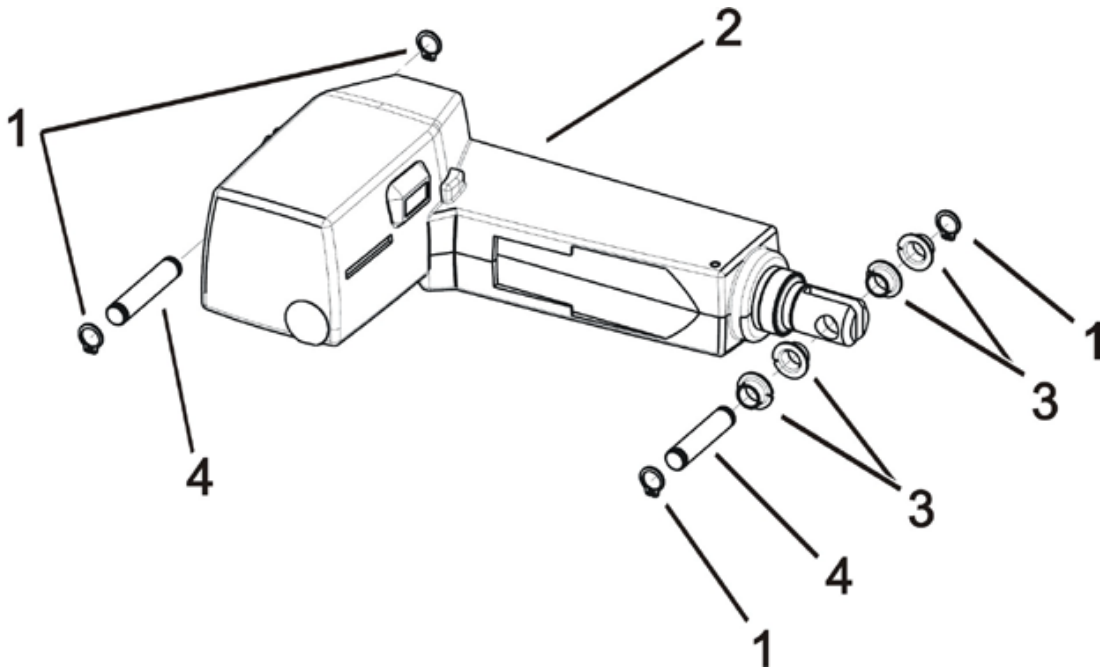

- Remove the retaining rings (1) with a pair of spring-ring pliers.
- Push the bolts (4) out of the guides. Pay attention to the bushings (3) on the front bolt.
- Remove the actuator from the lifter module.

Installing the lifter actuator:

- Assemble all parts in reverse order.
- Perform a function test.

Method 2 - uninstalling the lifter actuator with the lifter lowered**WARNING: Danger of crushing!**

The seat is very heavy. Danger of injury to hands and feet!

- Use proper lifting techniques.

**Requirements:**

- Spring-ring pliers
- Side cutting pliers
- Cable ties
- Bent-nose pliers
- 6 mm Allen key

**Note**

Take careful note of the exact position of the seat. Mark the position it is mounted in, the angle, the positions of all cables and so on. If necessary, make photographs with a digital camera. Any modification of the adjustment of the seat affects the centre of gravity of the wheelchair.

- Switch the electronic control system off.

The actuator module for the lifter and the tilt actuator are mounted to the front edge of the seat frame.

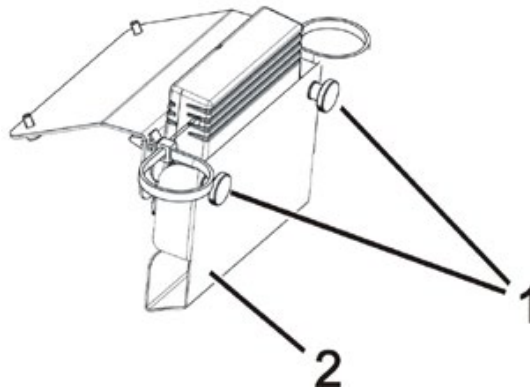

- Completely remove both knurled head screws (1) including the washers.
- Remove the cover (2).
- Disconnect the plug from the actuator module.
- Open the cable clips on the underside of the seat.
- Free up the actuator cable so that you can remove the seat.

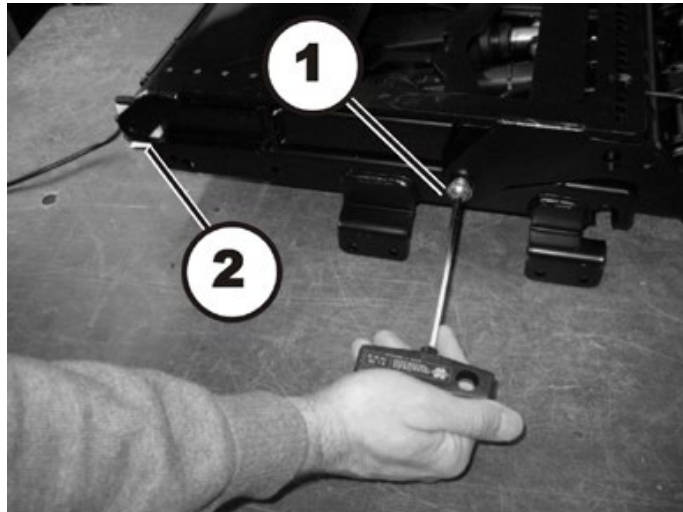

- Loosen and remove the hexagon socket head screw (1) of the seat frame on the left and on the right side of the wheelchair



WARNING: Danger of crushing!

The seat is very heavy. Danger of injury to hands and feet!

- Use proper lifting techniques.

- Lean the seat back and push the rear brackets (2) out of their guides.
- Remove the seat.

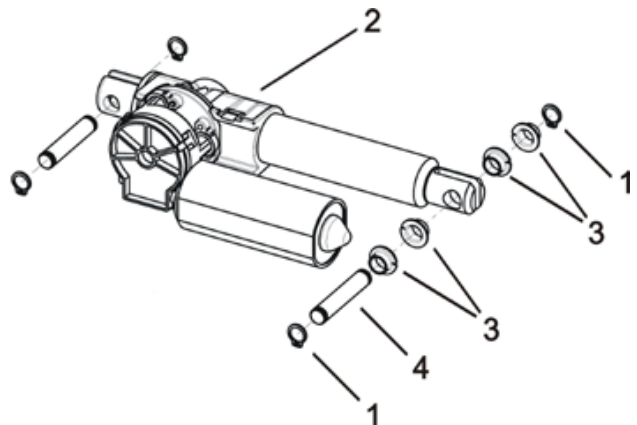

- Remove the retaining rings (1) with a pair of spring-ring pliers.
- Push the bolt (4) out of the guide. Pay attention to the bushings (3).



- Swing the tilt lever arm (1) forwards.

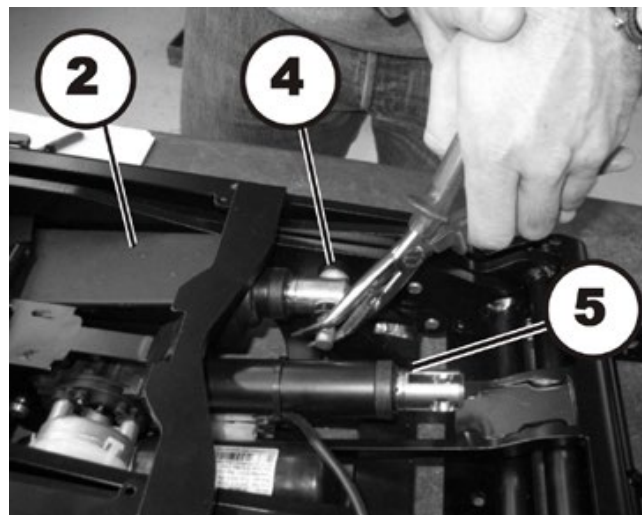
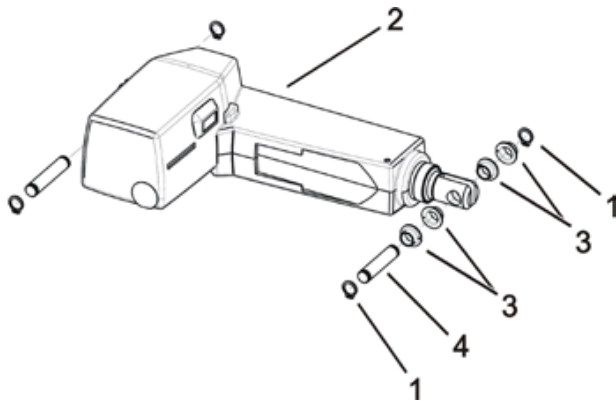

- Remove the retaining rings (1) from the front bolt (4) of the lifter actuator (2) with the spring-ring pliers.
- Pull the bolt out of the guide with a pair of bent-nose pliers, until the bolt almost touches the tilt actuator (5). Pay attention to the bushings (3).

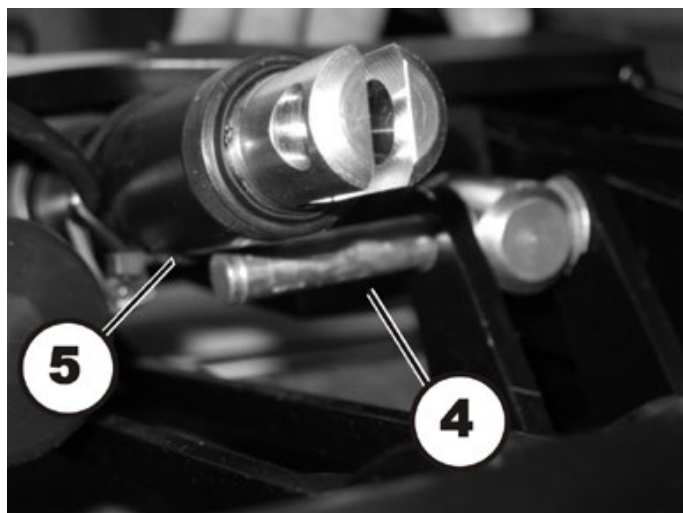

- Lift the tilt actuator (5) up a little.
- Pull the bolt (4) of the lifter actuator under the tilt actuator and out of the guide.

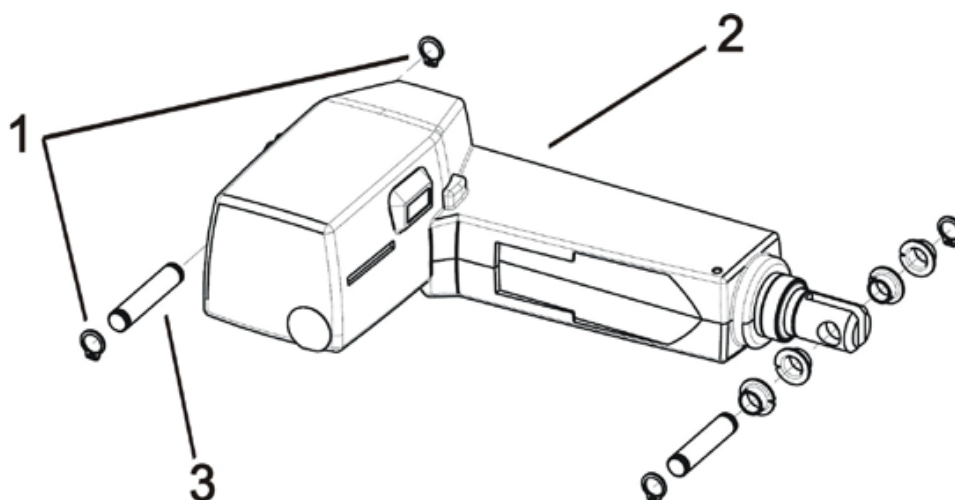

- Remove the retaining rings (1) from the rear bolt (3) of the lifter actuator (2) with the spring-ring pliers.
- Push the bolt out of the guides.
- Remove the actuator from the lifter module.

Installing the lifter actuator:

- Assemble all parts in reverse order.
- Perform a function test.

8.13.3 Seat frame

8.13.3.1 Adjusting the seat width

Note

The seat width can be adjusted in stages between 38 and 53 cm.
Please also observe the following chapter 8.13.3.2 on “adjusting the seat depth”.

Requirements:

- 4 mm Allen key

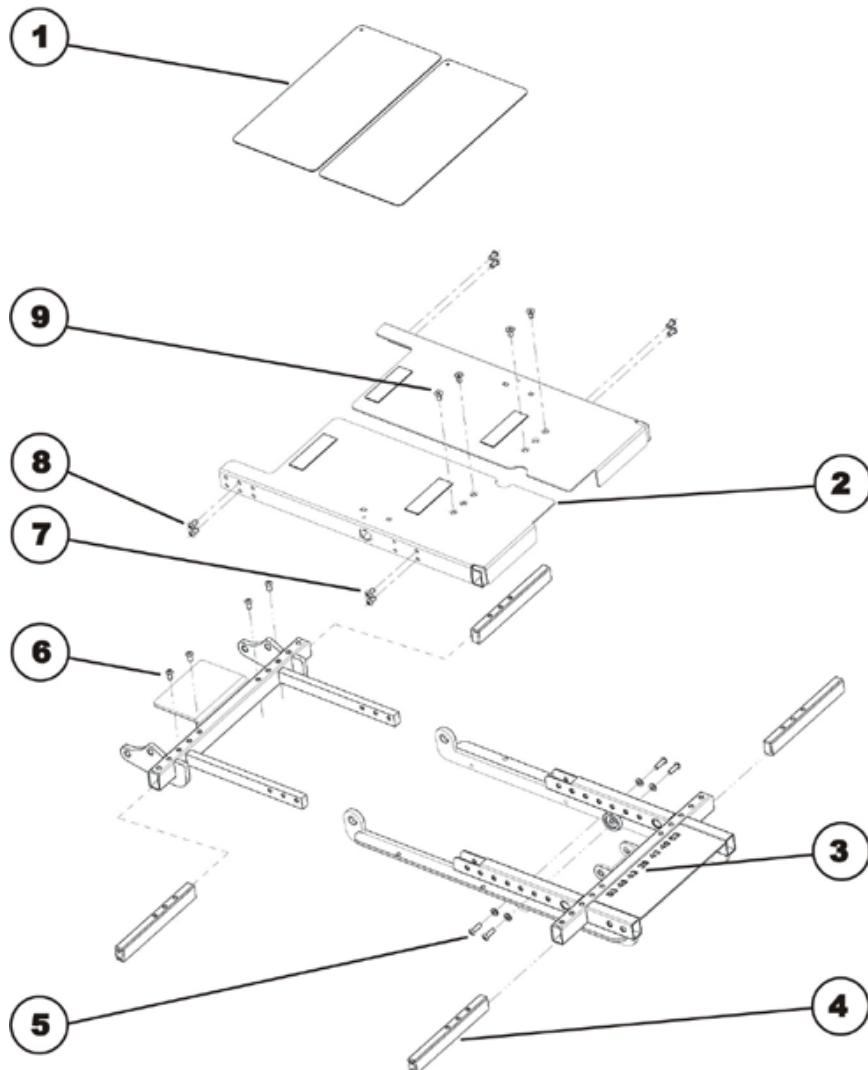

- Remove the seat cushion.
- Remove the cover plates (1).
- Release the two Allen screws (6) on the crossbar at the rear and remove them.
- Release the two upper front Allen screws (9) on the seat mounting plate and remove them.
- Loosen the four Allen screws at the front (7) and at the rear (8) that can be found on the side of the seat mounting plate in order to release tension and facilitate moving the plates. Do not remove these screws entirely.

- Pull or push the seat mounting plate (2) to the desired width. A scale (3) is included on the lower part of the seat support. You can read off the seat width in centimetres on the scale.
- Repeat these work steps on the other side of the seat.
- Now tighten all the screws again.

8.13.3.2 Adjusting the seat depth



Note

The seat depth can be adjusted in stages between 38 and 53 cm.
Please also observe preceding chapter 8.13.3.1 on “adjusting the seat width”.



Requirements:

- 4 mm Allen key
- 8 mm jaw spanner
- Oblique pliers
- Cable ties



Note

Certain holes in the seat support must be used for the screws depending on the desired seat depth. It may possibly be necessary to replace the seat support plates.

- Use the following illustration and the table to determine which holes must be used for the desired seat depth and whether the seat support plates possibly have to be replaced.

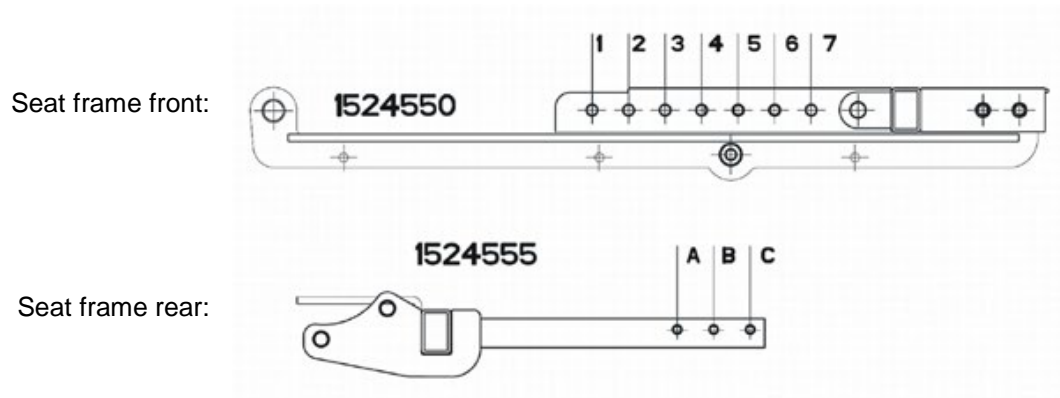

Seat depth in cm	Holes used in seat frame front Order no.: 1524550	Holes used in seat frame rear Order no.: 1524555	Required seat support plate
38	6 & 7	A & B	SHORT Order no. 1526437
41	5 & 7	A & C	
43	4 & 6	A & C	
43	4 & 6	A & C	MEDIUM Order no. 1526438
46	3 & 5	A & C	
48	2 & 4	A & C	
48	2 & 4	A & C	LONG Order no. 1526439
51	1 & 3	A & C	
53	1 & 2	B & C	

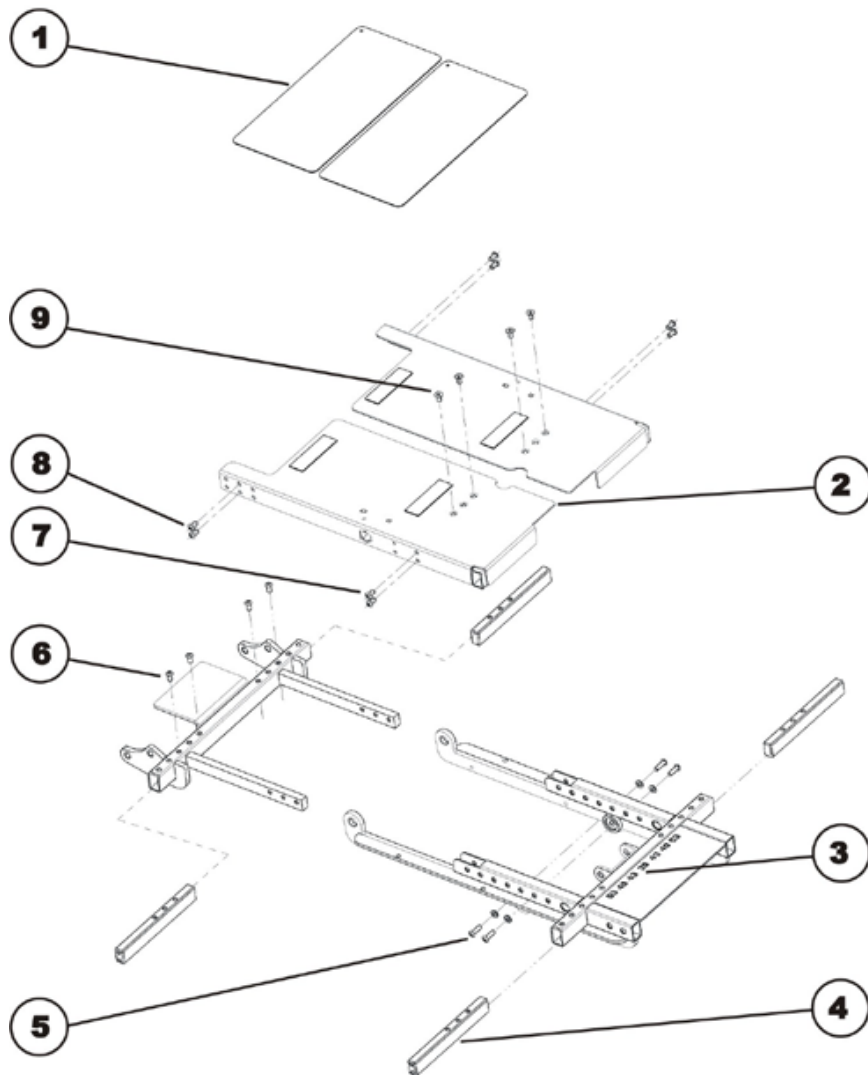

- Adjust the seat depth as described in the following chapters:
 - According to subchapter "Adjusting the seat depth without replacing the seat support plates" if the seat support plates do not have to be replaced.
 - According to subchapter "Adjusting the seat depth and replacing the seat support plates" if the seat support plates have to be replaced.

Adjusting the seat depth without replacing the seat support plates

- Remove the armrests.
- Remove the seat cushion.
- Remove the cover plates (1).
- Loosen and remove the two Allen screws (8) on the rear side of the seat support plate connecting this to the cross braces (4).
- Repeat this work step on the other side of the seat.
- Loosen and remove the two Allen screws (5) incl. the washers.

Assembly:

- Pull the seat support to the desired length so that the Allen screws (5) can be placed in the holes according to the table (see above).
- Refit the Allen screws (5) incl. the washers and tighten them.
- Fit the two Allen screws (8) on the rear side of the seat support, connecting this to the cross braces (4). Unlike dismantling, different holes in the three pairs of holes must be used for the screws.
- Refit all parts that were removed.

Adjusting the seat depth and replacing the seat support plates

Disassembly:

- Remove the legrests.
- Remove the armrests.
- Remove the seat cushion.
- Remove any existing cable ties holding the remote or lighting cables. Release the cables from the stuck on clamps.
- Loosen the cap nuts of the headlight mountings using an 8 mm jaw spanner (see chapter 8.6.3 or 8.6.5).
- Put the headlights and the mounting in a safe place on the rear part of the battery compartment cover.
- Remove the cover plates (1).
- Loosen the two Allen screws (9) at the top front of the seat support plate and remove them.
- Loosen the two Allen screws (7) on the front side of the seat support plate connecting this to the cross braces (4).
- Loosen the two Allen screws (8) on the rear side of the seat support plate, connecting this to the cross braces (4).
- Remove the seat support plate (2).
- Repeat this work step on the other side of the seat.
- Loosen and remove the two Allen screws (5) incl. the washers.

- Pull the seat support to the desired length so that the Allen screws (5) can be fitted into the holes according to the table (see above).
- Refit the Allen screws (5) incl. the washers and tighten them.
- If necessary, replace the seat support plates (2) according to the table (see above).
- Refit the seat support plate (2).
- Fit the two Allen screws (7) on the front side of the seat support, connecting this to the cross braces (4).
- Fit the two Allen screws (8) on the rear side of the seat support, connecting this to the cross braces (4). Unlike the dismantling of the old plates, other holes of the three pairs of holes may possibly have to be used for the screws.
- Fit the two Allen screws (9) at the front of the seat support plate.
- Refit all parts that were removed.

8.14 Centre-mounted legrest (electric & manual)



Note

The centre-mounted legrest is the only part of the wheelchair, in which screw sizes are indicated in inches.

8.14.1 Replacing the manually operated centre-mounted legrest



WARNING: Danger of crushing!

The legrest is very heavy. Danger of injury to hands and feet!

- Pay attention to the heavy weight.



Requirements:

- 5 mm Allen key
- 6 mm Allen key
- Side cutting pliers
- Cable ties

Uninstalling the manually operated centre-mounted legrest:

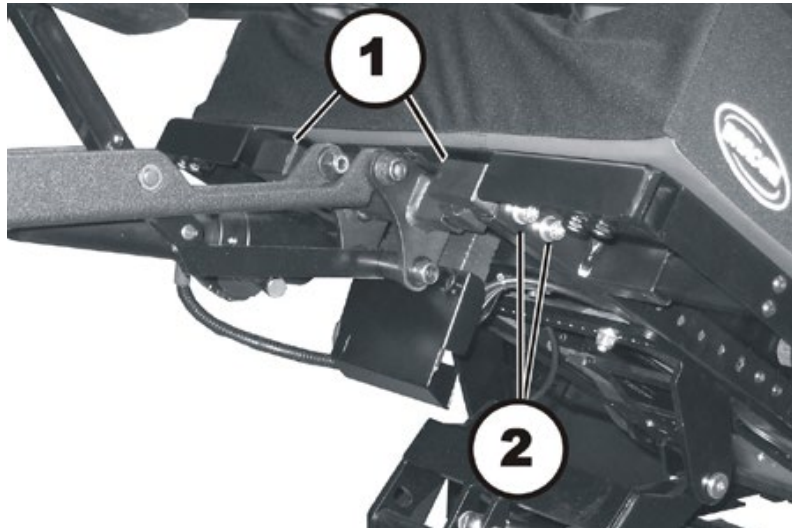

An electric legrest can be seen in the illustration. The method of fixation to the seat is identical with both legrests.

- Uninstall the locking lever for the height adjustment of the legrest, by loosening the grub screws with a 5 mm Allen key.
- Use the 6 mm Allen key to loosen and remove the two hexagon socket head screws (2) on both sides of the wheelchair.
- Completely remove both hexagon socket head screws, including the washers.
- Pull the entire legrest forwards out of the seat.
- Loosen both hexagon socket head screws, which attach the adapter brackets (1) to the legrest.
- Remove both adapter brackets.

Installing the manually operated centre-mounted legrest:

- Assemble the parts in reverse order.
- Test all functions of the wheelchair.

8.14.2 Replacing the electrically operated centre-mounted legrest



WARNING: Danger of crushing!

The legrest is very heavy. Danger of injury to hands and feet!

- Pay attention to the heavy weight.



Requirements:

- 6 mm Allen key
- Side cutting pliers
- Cable ties

Uninstalling the electrically operated centre-mounted legrest:

- If possible, raise the lifter to the highest position.
- If possible, tip the wheelchair with the tilt module as far backwards as it will go.
- Switch the electronic control system off.

The actuator module for the lifter and the tilt actuator are mounted to the front edge of the seat frame.

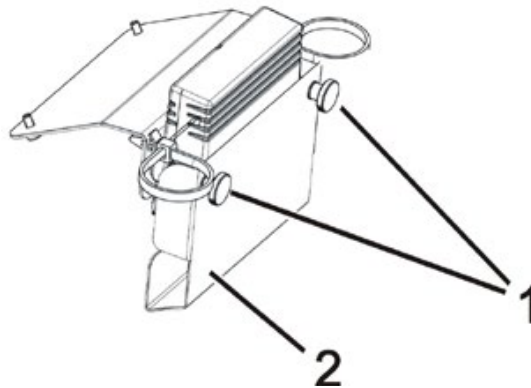

- Completely remove both knurled head screws (1) including the washers.
- Remove the cover (2).
- Pull the plug of the legrest actuator out of the actuator module.

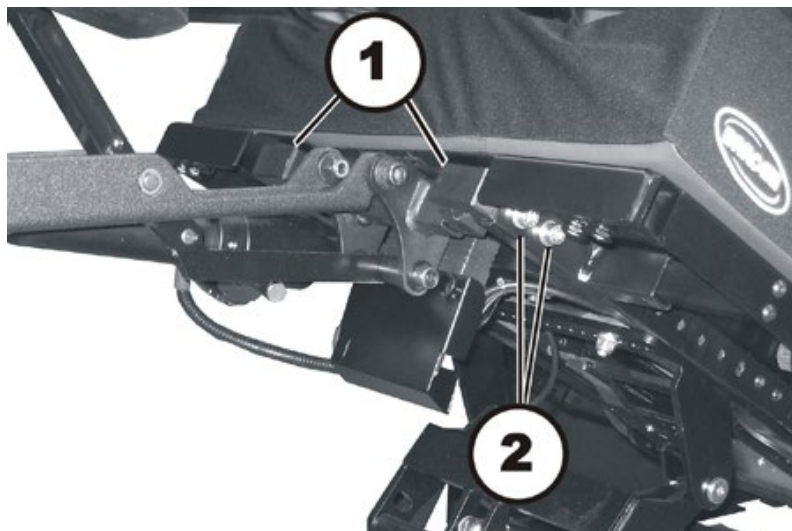

- Use the 6 mm Allen key to loosen and remove the two hexagon socket head screws (2) on both sides of the wheelchair.
- Completely remove both hexagon socket head screws, including the washers.
- Pull the entire legrest forwards out of the seat.
- Loosen both hexagon socket head screws, which attach the adapter brackets (1) to the legrest.
- Remove both adapter brackets.

Installing the electrically operated centre-mounted legrest:

- Assemble the parts in reverse order.
- Test all functions of the wheelchair.

8.14.3 Replacing the electrically operated centre-mounted legrest LNX (Modulite seat)



WARNING: Danger of crushing!

The legrest is very heavy. Danger of injury to hands and feet!

- Pay attention to the heavy weight.



Requirements:

- 4 mm Allen key
- 10 mm ring spanner or jaw spanner

Uninstalling the electrically operated centre-mounted legrest LNX:

- If possible, raise the lifter to the highest position.
- If possible, tip the wheelchair with the tilt module as far backwards as it will go.
- Switch the electronic control system off.
- Pull the plug of the legrest actuator out of the actuator module.

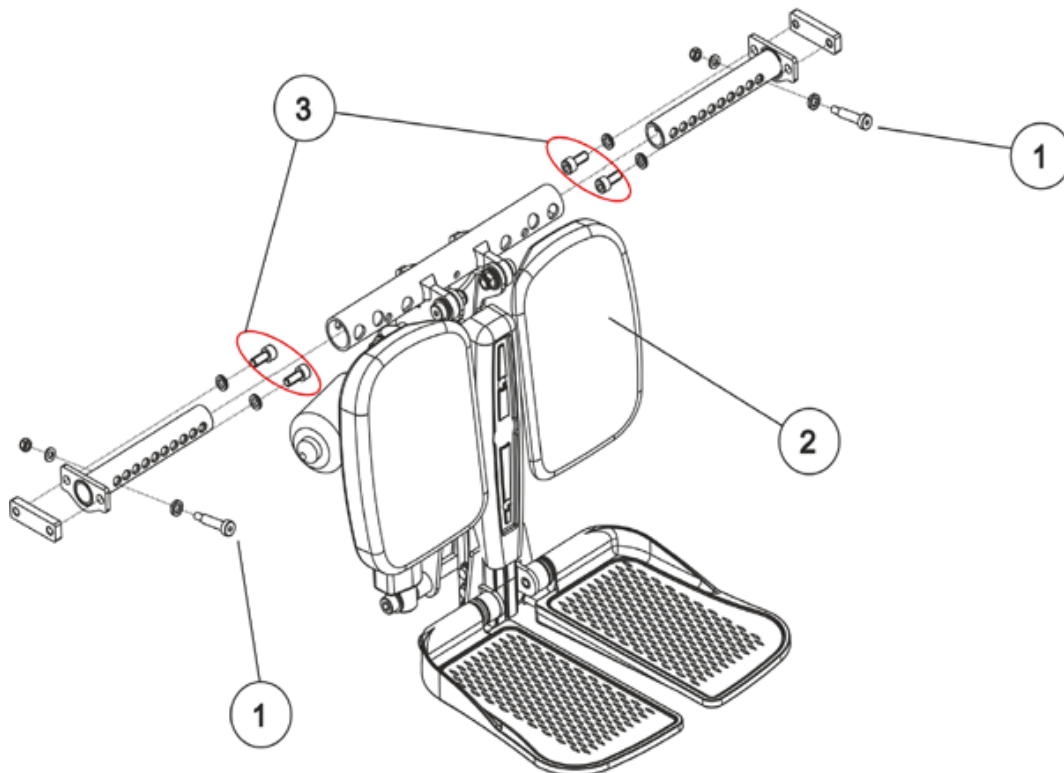

- Loosen the screws (3) with a 6 mm Allen key. Pull the entire legrest (2) forwards out of the seat frame profile.
- Loosen and remove the screws (1) including the nuts and washers with a 4 mm Allen key and a 10 mm ring spanner or jaw spanner.
- Replace the legrest (2).

Installing the electrically operated centre-mounted legrest LNX:

- Assemble the parts in reverse order.
- Test all functions of the wheelchair.

8.14.4 Replacing an electric legrest actuator**WARNING: Danger of crushing!**

The legrest is very heavy. Danger of injury to hands and feet!

- *Pay attention to the heavy weight.*

**Requirements:**

- 1/2" socket wrench
- 3/8" Allen key
- Side cutting pliers
- Cable ties

Uninstalling the electrically operated legrest:

- If possible, raise the lifter to the highest position.
- If possible, tip the wheelchair with the tilt module as far backwards as it will go.
- Switch the electronic control system off.

The actuator module for the lifter and the tilt actuator are mounted to the front edge of the seat frame.

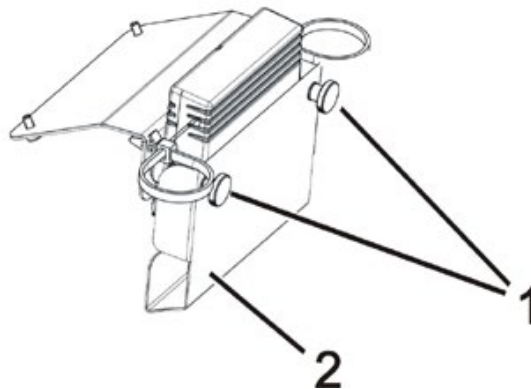

- Completely remove both knurled head screws (1) including the washers.
- Remove the cover (2).
- Pull the plug of the legrest actuator out of the actuator module.

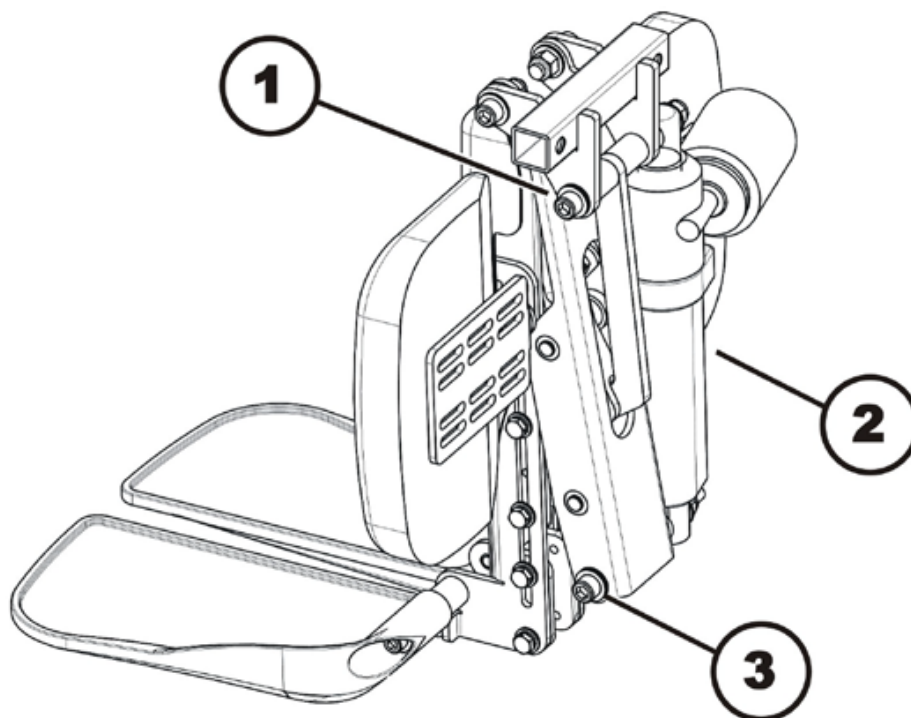

- Use the 3/8" Allen key and a 1/2" socket wrench to loosen the screw (3).
- Use the 3/8" Allen key and a 1/2" socket wrench to loosen the screw (1).
- Remove the nuts including the washers, but leave the screw inserted in the screw hole, do not pull it completely out.
- Pull the actuator (2) toward the side off of the screws (1) and (3).
- Replace the actuator.

Installing the electrically operated legrest:

- Assemble the parts in reverse order.
- Test all functions of the wheelchair.

8.14.5 Replacing the calf plate on the centre-mounted legrest (electric & manual)

**Requirements:**

- 1/64" Allen key

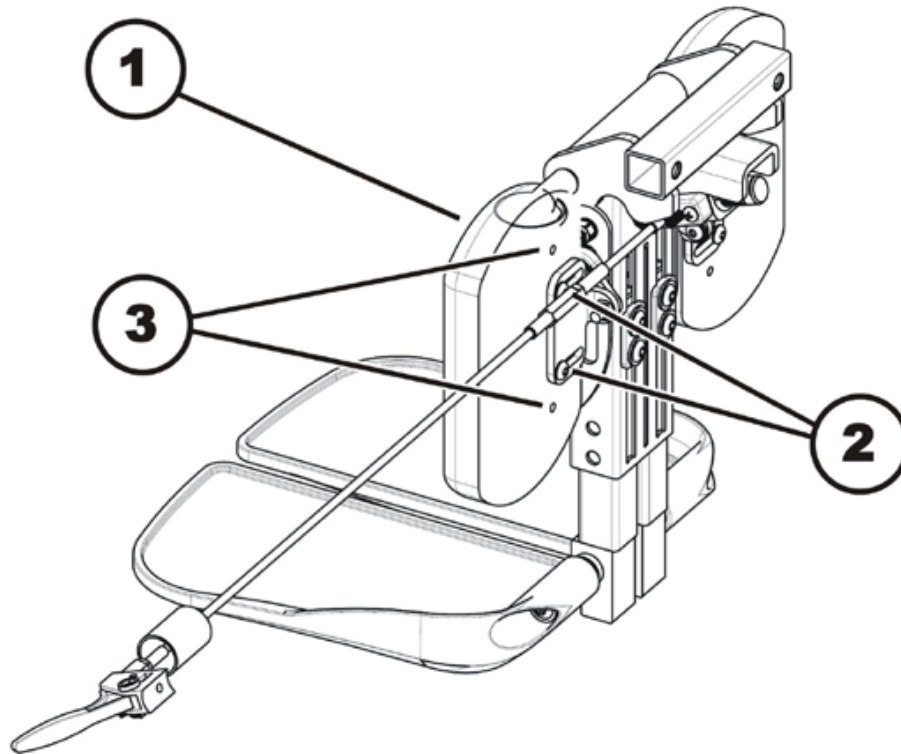

A manual legrest can be seen in the illustration. The method of fixation to the seat is almost identical with both legrests.

Uninstalling the calf plate:

- If possible, raise the lifter to the highest position.
- If possible, tip the wheelchair with the tilt module as far backwards as it will go.
- Switch the electronic control system off.
- Use the 1/64" Allen key to loosen and remove both screws (2).
- Remove the calf plate (1).

Installing the calf plate:

- Assemble the parts in reverse order.
- Using the different adjustment holes (3) in the calf plate and in the calf plate brackets, the calf plates can be mounted at different heights and widths. This must be adjusted to fit the needs of the user.

8.14.6 Replacing the foot plate on the centre-mounted legrest (electric & manual)

Requirements:

- 1/64" Allen key
- 1/4" Allen key

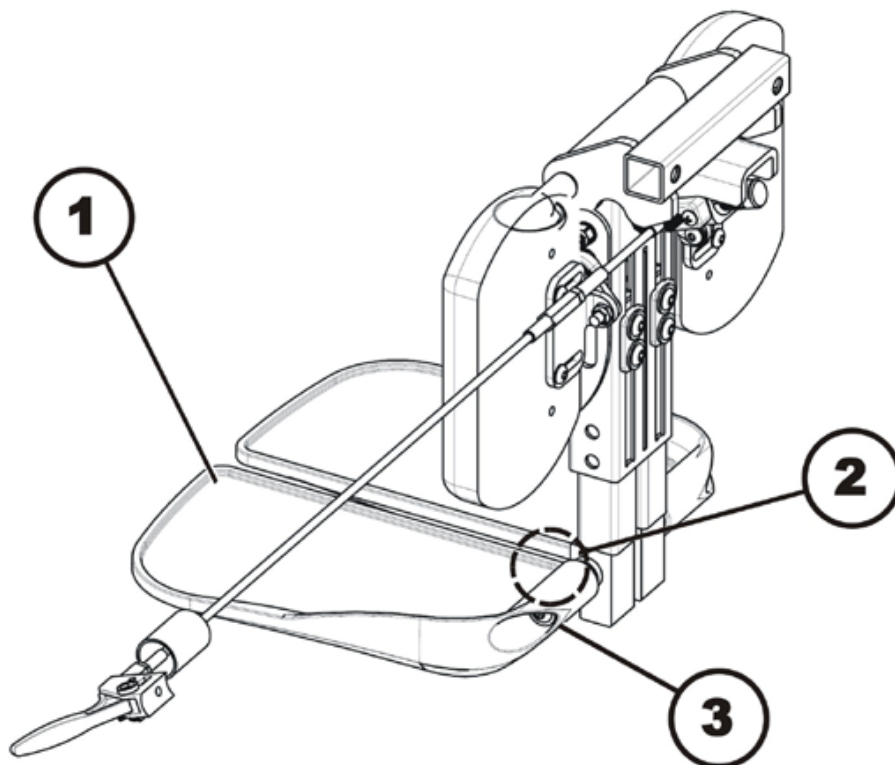

A manual legrest can be seen in the illustration. The method of fixation to the seat is almost identical with both legrests.

Uninstalling the footplate

- If possible, raise the lifter to the highest position.
- If possible, tip the wheelchair with the tilt module as far backwards as it will go.
- Switch the electronic control system off.
- Use the 1/64" Allen key to loosen and remove both screws (3).
- Replace the foot plate (1).

Installing the footplate:

- Assemble the parts in reverse order.
- Tighten the hexagon socket head screws (3) till they are tight enough that the footplate can barely be moved.

In the area denoted by the (2) there is an adjustment screw that can only be reached when the footplate is swivelled upwards.

- Use the 1/64" Allen key to adjust the angle of the footplate to the needs of the user with this screw.

8.15 Back unit

8.15.1 Replacing the standard back

Requirements:

- 5 mm Allen key
- Socket spanner, 13 mm

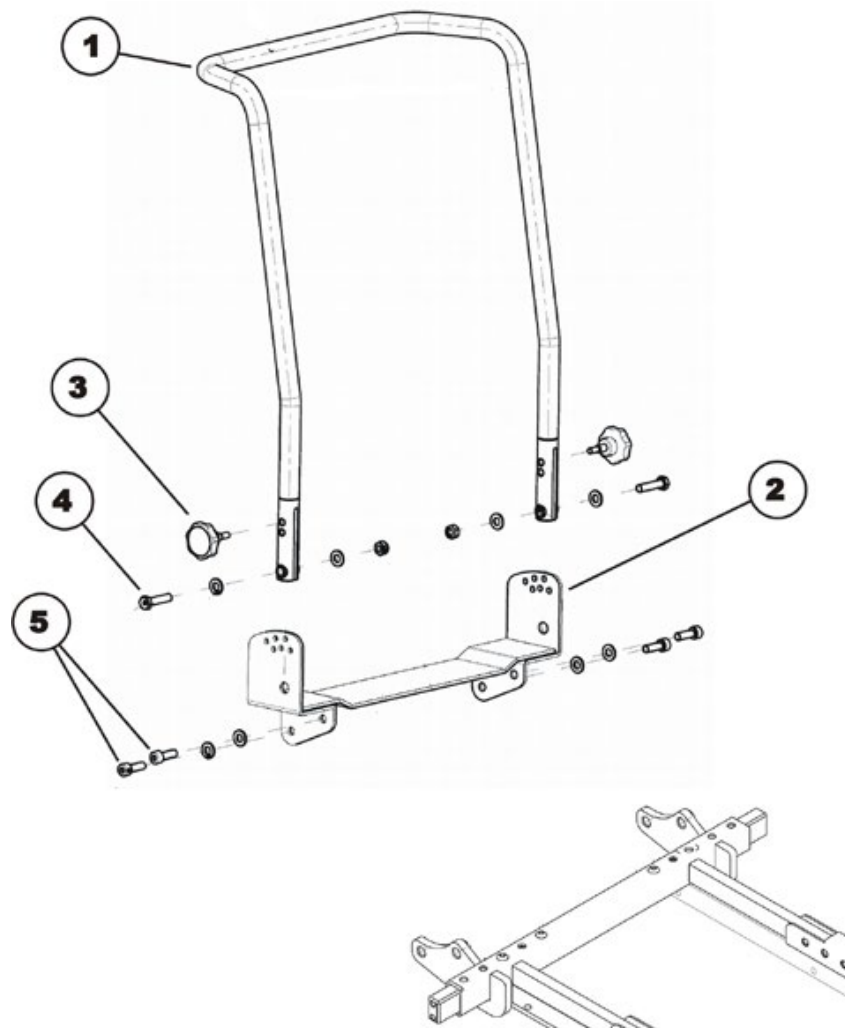
Dismantling the back unit:

- Remove the back cushion.
- Loosen and remove the handwheels (3) and the Allen screws (4) including the washers on the left and right side of the mobility aid.
- Carefully remove the rear pipe (1) of the back bracket (2).
- If the backrest holders also need to be replaced: undo and remove the Allen screws (5) including the washers on the left-hand and right-hand side of the chair.

Refitting the back unit:

- Refit the parts in reverse order.
- To conclude, check all the mobility aid functions.

8.15.2 Adjusting the belt back

The belt back can be individually adapted to the back shape of the user.

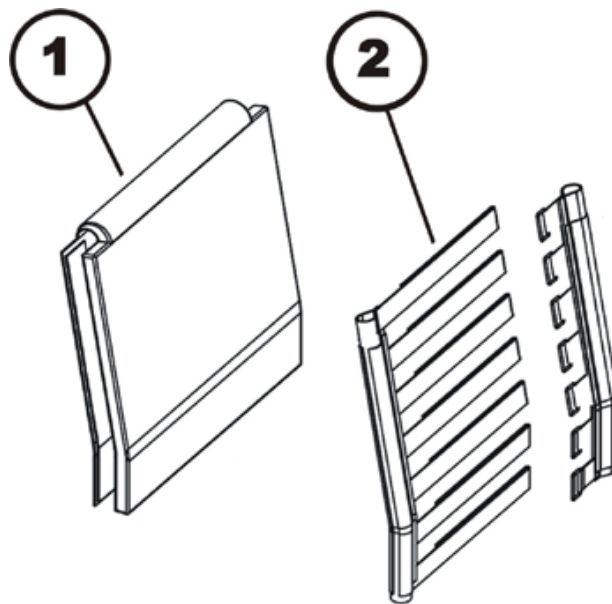

- Pull apart the front and back of the back cushion (1) and remove it. Front and back of the back cushion is held together by Velcro.
- Open Velcro straps of the back straps (2) and set it to the desired length.
- Refit the back cushion and fasten with Velcro.

8.15.3 Replacing the EasyAdapt back

**Requirements:**

- 5 mm Allen key
- Oblique pliers
- Cable ties

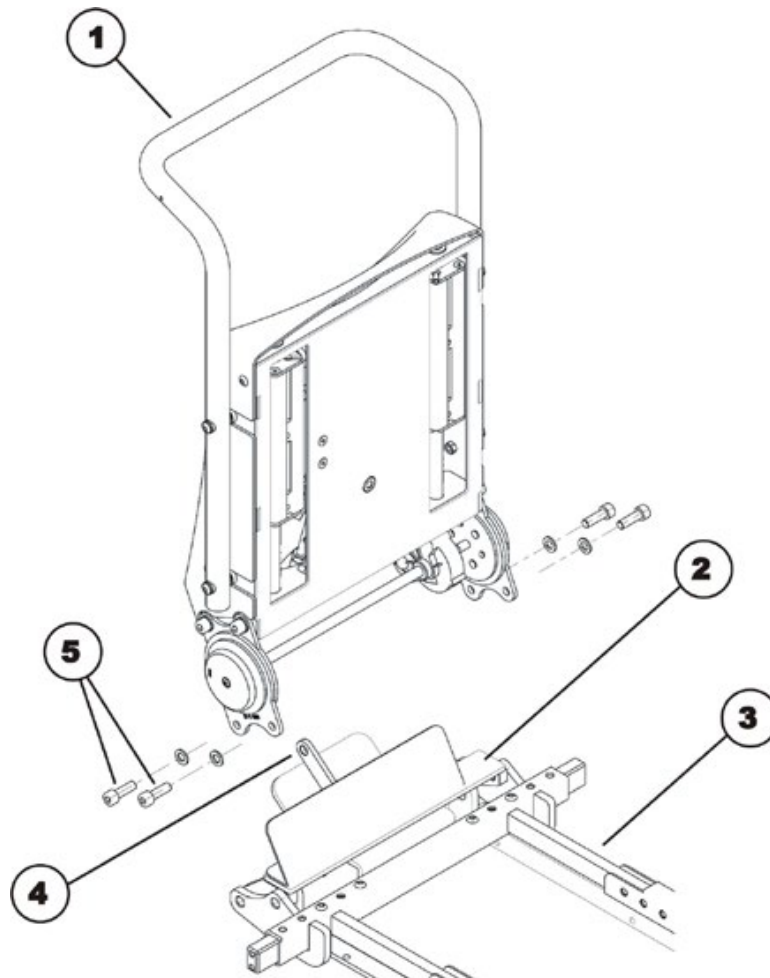
**Dismantling the back unit:**

- Remove the back cushion.
- Pull the actuator cable out of the actuator module under the seat.
- Pull the cable out of the mobility aid. Remove any cable ties which are fitted.
- Loosen and remove the Allen screws (5) incl. the washers on the left and right side of the seat.
- Carefully remove the back section (1) together with the lower part (2) from the seat support (3). The two parts are interconnected via the arm (4).

Refitting the back unit:

- Refit the parts in reverse order.
- To conclude, check all the mobility aid functions.

8.15.4 Replacing / adjusting the universal backrest frame for the EasyAdapt backrest

**Requirements:**

- Measuring tape
- Adhesive tape
- 13 mm open-end wrench
- 4 mm Allen key
- 5 mm Allen key
- Phillips screwdriver, size 2

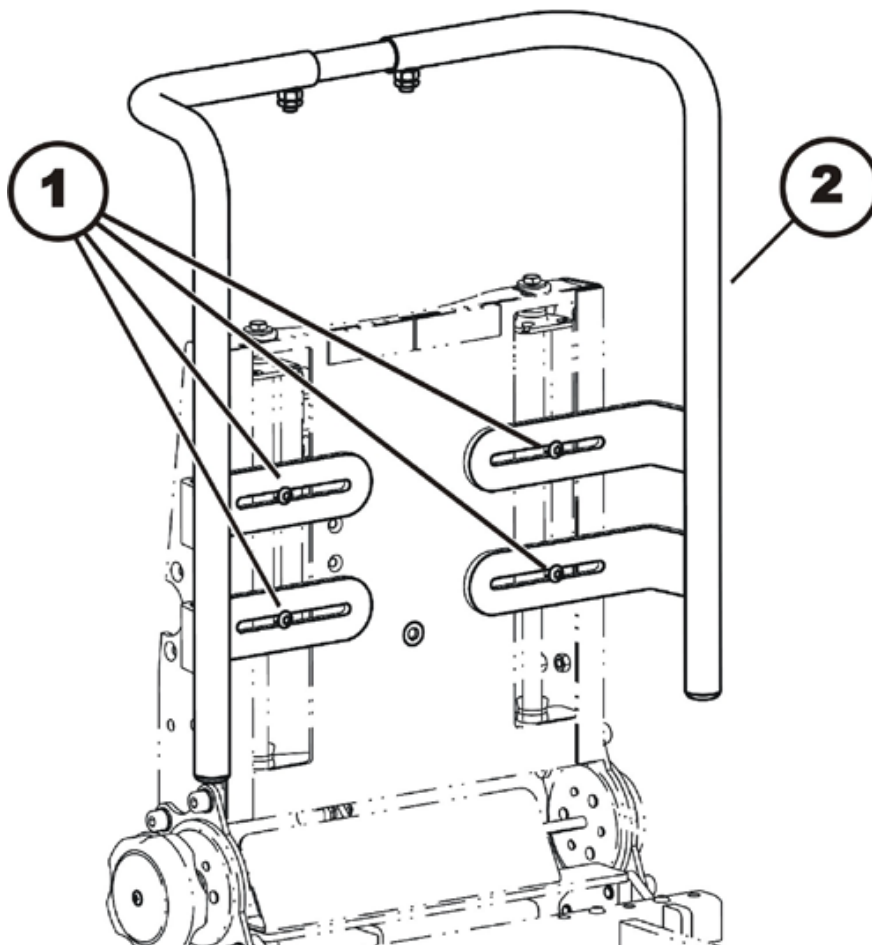
Uninstalling the universal backrest frame:

- Remove the backrest cushion.
- Loosen and remove the four Allen screws (1) with a 5 mm Allen key.
- Remove the universal backrest frame (2) from the EasyAdapt backrest.

Installing and adjusting the universal backrest frame:

**CAUTION!**

The upholstery may get damaged.

- *When adjusting the backrest frame, make sure the upholstery cannot collide with other components.*
-

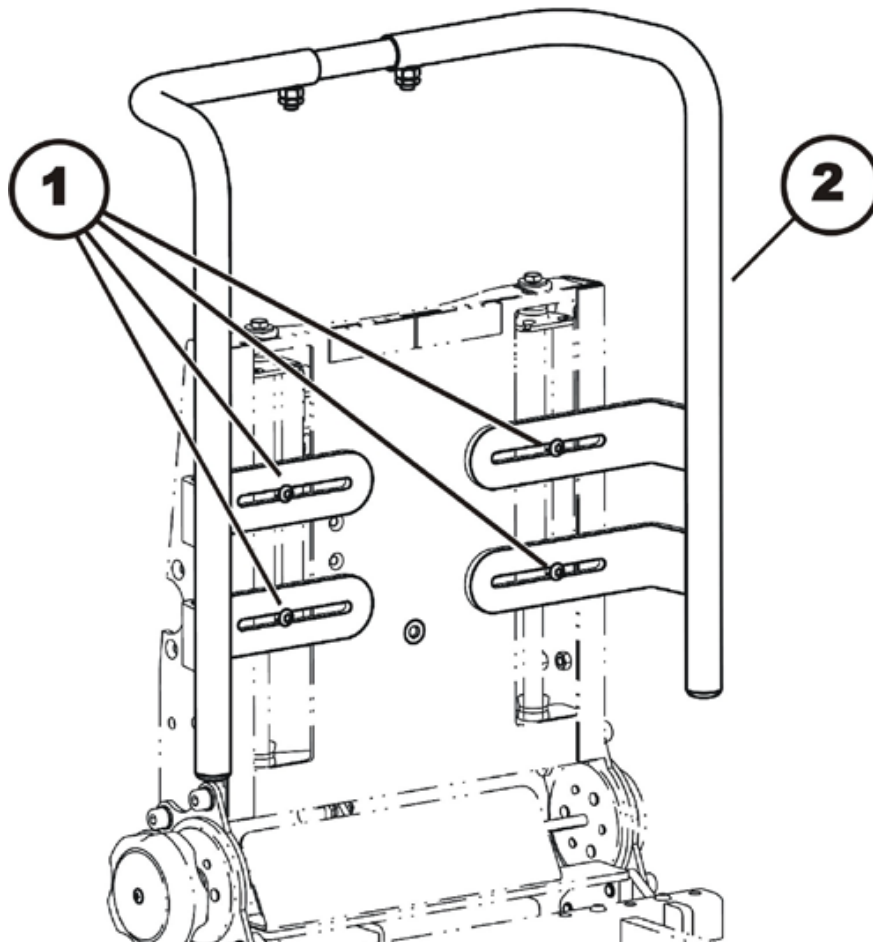

- Position both of the protective caps (8) in the lower ends of the lateral tubes (1).
- Mark the center of the middle tube (2) with a piece of adhesive tape.
- Insert the middle tube into the upper ends of the lateral tubes.
- Position the lateral tubes of the EasyAdapt backrest so that the four Allen screws (7) can be screwed into the slot nuts (6) through the oblong holes. Tighten the Allen screws just tight enough that the lateral tubes can slide and be adjusted without difficulty.
- Adjust the distance between the lateral tubes to the desired value using the measuring tape. Make sure both lateral tubes are at an equal distance to the center of the seat.
- Tighten the four Allen screws (7) using a 5 mm Allen key.
- Adjust the middle tube (2) so it is well centered.
- Screw both of the threaded pins (5) into the threaded holes (3) with a 4 mm Allen key.
- Secure the threaded pins additionally with the counter nuts (4). Tighten the counter nuts hand-tight with a 13 mm open-end wrench.

- Screw the four Phillips screws (9) into the drill holes provided for this purpose on the backs of the tubes. The screws serve as limiters and prevent the backrest from sliding down too far.
- Remove the marking from the middle tube.

8.16 Back unit with ergonomic length adjustment

8.16.1 Adjusting the width

**Note**

Please also observe preceding chapter 8.13.3.1 on “adjusting the seat width”.
By default the seat can be adjusted in width between 38 and 53 cm.

**Requirements:**

- 4 mm Allen key

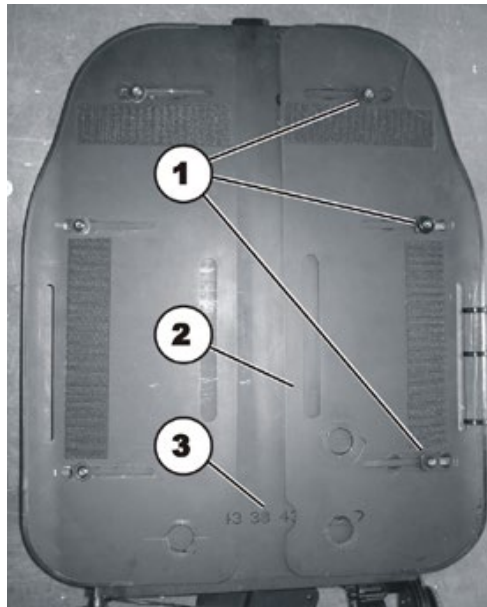

- Remove the back cushion.
- Loosen the three Allen screws (1) but do not remove them completely.
- Move the plate (2) until the desired width in centimetres can be read off the scale (3).
- Tighten the three Allen screws.
- Repeat this work step on the other back plate.
- Fit a back cushion in the appropriate width.

8.16.2 Replacing the planetary gear



Requirements:

- 4 mm Allen key
- 5 mm Allen key
- 13 mm jaw spanner
- Size 2 Phillips recessed head spanner
- Snap ring pliers

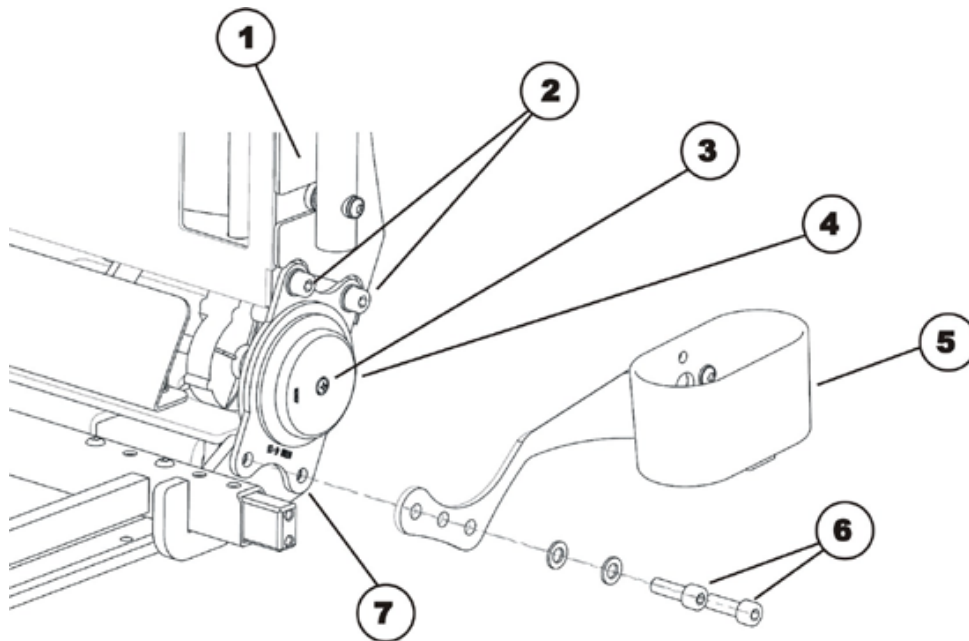

Dismantling the planetary gear:

- Loosen and remove the four Allen screws on the plastic cover (1) using a 4 mm Allen key.
- Remove the plastic cover.
- Loosen and remove the Phillips screw (3).
- Remove the reflector (4).
- Remove the snap ring under the reflector (not in the picture).
- Undo the two Allen screws (6) with a 5 mm Allen key.
- Remove the Allen screws (6) incl. the washers and the stick holder (5) if necessary.
- When replacing both planetary gears or dismantling the entire back section, also now loosen and remove the Allen screws (6) incl. the washers on the other side of the mobility aid.
- Undo the two Allen screws (2) with a 5 mm Allen key. You will need an additional 13 mm jaw spanner for the opposite nut on the right side of the mobility aid.
- Remove the Allen screws (2) incl. the washers and the nut if necessary.
- Pull the planetary gear from the axle.
- Replace the planetary gear.

Refitting the planetary gear:

- Refit the parts in reverse order.
- To conclude, check all the mobility aid functions.

8.16.3 Replacing the servo motor

Requirements:

- 4 mm Allen key
- 5 mm Allen key
- 10 mm socket spanner
- 13 mm jaw spanner
- Size 2 Phillips recessed head spanner
- Snap ring pliers

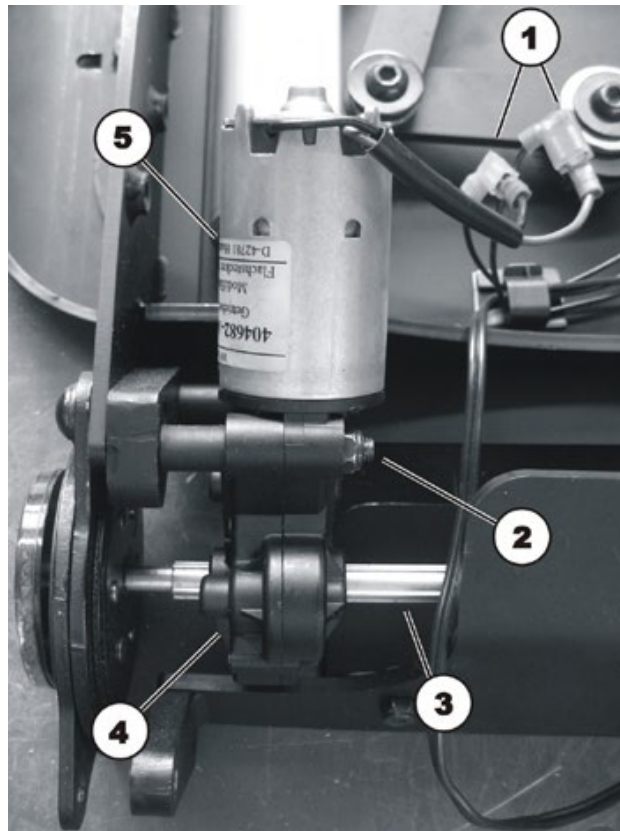
Fitting the planetary gear:

- Disconnect the two motor plugs (1).
- Dismantle the entire back section and remove both planetary gears as described in chapter 8.16.2.
- Loosen and remove the two nuts (2): only the upper nut is visible in the illustration.
- The motor (5) and the gear (4) form one unit. Pull them from the axle together (3).
- Replace the motor/gear unit.

Refitting the planetary gear:

- Refit the parts in reverse order.
- To conclude, check all the mobility aid functions.

8.16.4 Replacing the microswitch

**Requirements:**

- 4 mm Allen key
- Size 2 Phillips recessed head spanner

Dismantling the microswitch:

- Loosen and remove the four Allen screws on the backrest plastic cover using a 4 mm Allen key.
- Remove the plastic cover.

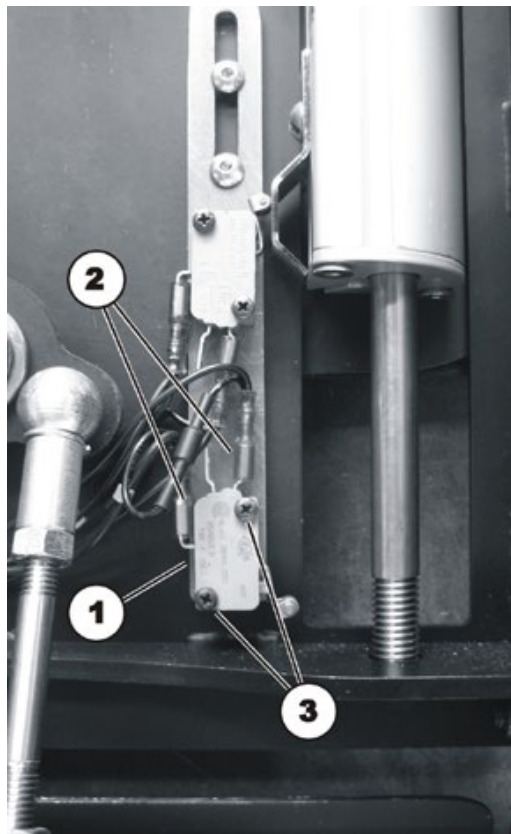

- Pull the plugs (2) out of the microswitch (1).
- Loosen and remove the two Phillips screws (3)
- Replace the microswitch.

Refitting the planetary gear:

- Refit the parts in reverse order.
- To conclude, check all the mobility aid functions.

8.16.5 Fitting back plates to the base support of the back with ergonomic length adjustment



Requirements:

- 4 mm Allen key

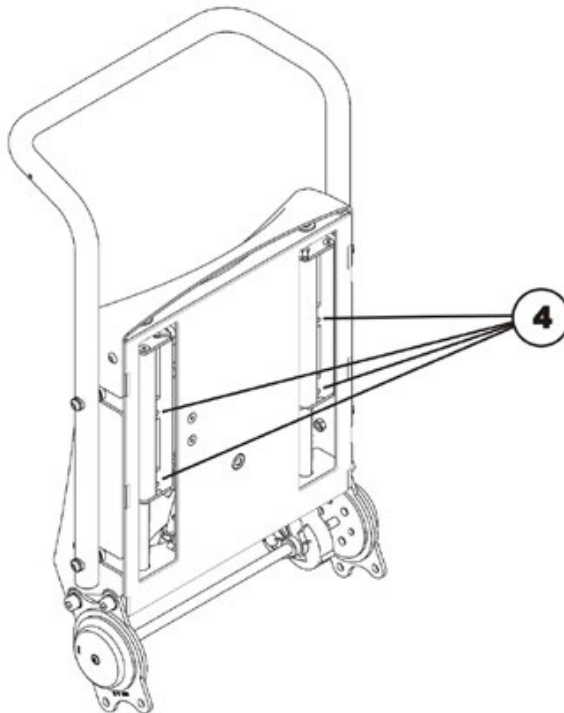
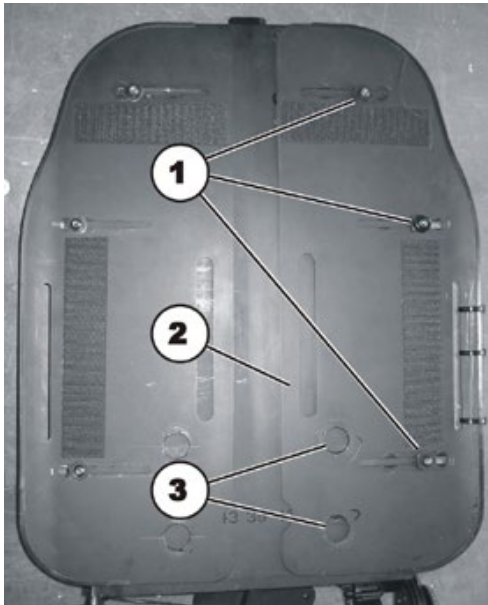

- Loosen the three Allen screws (1) but do not remove them completely.
- Move the back plate (2) so that the large boreholes (3) are above the lower screw holes of the centre back plate.
- Tighten the three Allen screws slightly.
- Repeat this on the second back plate.
- Move the back of the seat to the rearmost position.
- Slide the two lower slot nuts (4) in the left hand and right hand groove right down to the bottom.
- Push the upper ones so far to the top that the distances of the slot nuts coincide with the distances of the screw holes.
- Place the centre part of the back plate (3) on the backrest so that the four boreholes coincide with the slot nuts (4).
- Fit the four supplied Allen screws and tighten them.
- Adjust the desired seat width with the help of the included centimetre scale.
- Tighten the six Allen screws (1) firmly.

8.16.6 Fitting the handlebar

**Requirements:**

- 4 mm Allen key

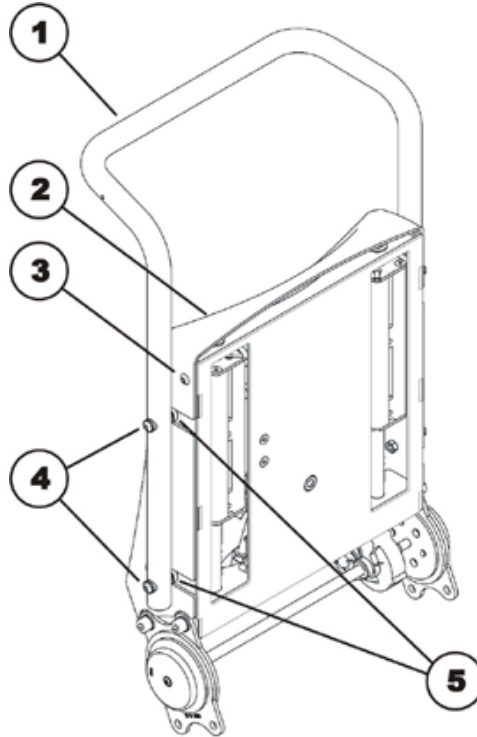

- Loosen and remove the four Allen screws (3) on the plastic cover.
- Remove the plastic cover (2).
- Remove the covers on the washer recesses (5).
- Arrange the handlebar (1) on the back section in such a way that the boreholes coincide with the tapped holes in the back section.
- Fit the four Allen screws (4) incl. the washers (5) and tighten the screws.
- Refit the plastic cover.
- Refit the six Allen screws (3) and tighten them.

8.16.7 Replacing the travelling armrest

**Requirements:**

- 4 mm Allen key

Dismantling the travelling armrest

- Undo and remove the four Allen screws in the backrest plastic cover using a 4 mm Allen key.
- Remove the plastic cover.
- If necessary, remove the remote together with its cable.

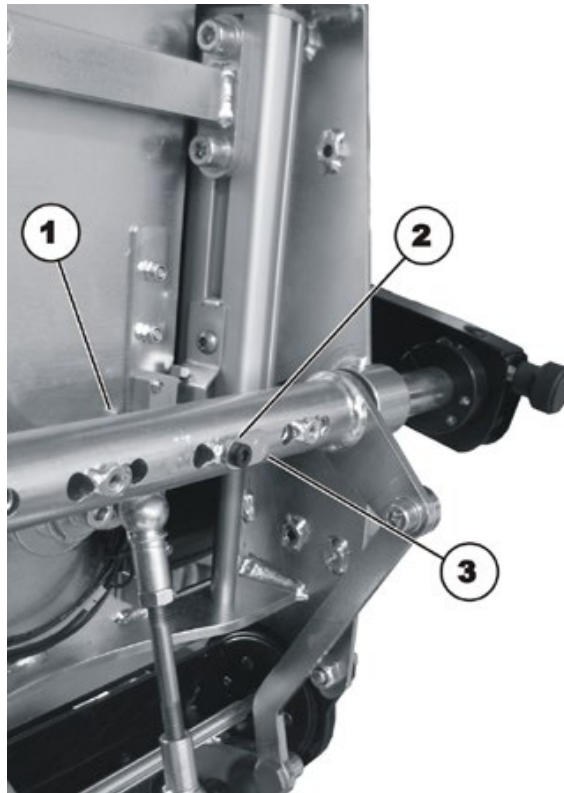

- On the torque support, loosen the locating pin (3) bolt (2) with a 4 mm Allen key.
- Raise the armrest slightly and remove the locating pin.
- Pull the armrest out of the torque support to the side. If you raise and lower the armrest a few times it is easier to remove.
- Replace the armrest.

Refitting the travelling armrest

- Replace the parts in the reverse order.
- To complete, check all vehicle functions.

The new armrest will need to be adjusted to suit the user. Please refer to the mobility device operating manual for detailed information.

8.16.8 Replacing the arm support on the travelling armrest

**Requirements:**

- 4 mm Allen key

Dismantling the arm support

- If necessary, remove the remote together with its cable.
- Rotate the armrest upwards.



- Undo the two holding bolts (1) with a 4 mm Allen key.
- Replace the arm support.

Refitting the travelling armrest

- Replace the parts in the reverse order.
- To complete, check all vehicle functions.

The new armrest will need to be adjusted to suit the user. Please refer to the mobility device operating manual for detailed information.

8.16.9 Retrofitting a travelling armrest



NOTE

The travelling armrest can only be retrofitted if the entire backrest is replaced since the torque support must be fitted with the correct guides.

Retrofitting the travelling armrest

- Fit the backrest for the travelling armrest as described in chapter 8.15.3.
- Fit the armrests as described in chapter 8.16.7.
- Fit the arm supports as described in chapter 8.16.8.

The new armrest will need to be adjusted to suit the user. Please refer to the mobility device operating manual for detailed information.

8.17 Seat adjustment Modulite

8.17.1 Seat / seat frame Modulite (without lifter)



Note

This chapter describes how to replace the seat frame on a wheelchair without a lifter or tilt module. To replace a lifter or tilt module, please follow the procedures explained in chapter 8.17.4.



WARNING: Danger of crushing!

The seat is very heavy. Danger of injury to hands and feet!

- Use proper lifting techniques.



Requirements:

- 6 mm Allen key
- Torque wrench 5 – 30 Nm (or similar)
- Protractor
- Side cutting pliers
- Cable ties
- Wooden block



Note

Take careful note of the exact position of the seat. Mark the position it is mounted in, the angle and so on. If necessary, make photographs with a digital camera. Any modification of the adjustment of the seat affects the centre of gravity of the wheelchair.

Removing the seat:

- Switch the wheelchair off.
- Remove the front cover and the rear covers, as described in chapters 8.1.1 and 8.1.2.

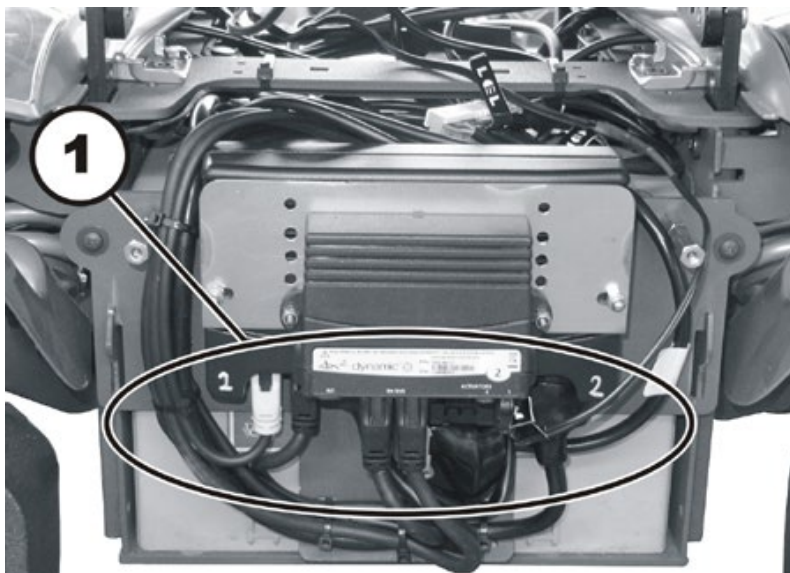

- Take exact note of the positions of all cables and the sockets (1) that they are connected to. Mark the connectors and sockets or take a photograph with a digital camera.
- Detach all cables from the electronic modules which run from the seat to the chassis.
- Place the cables so that they do not get in the way when you remove the seat.

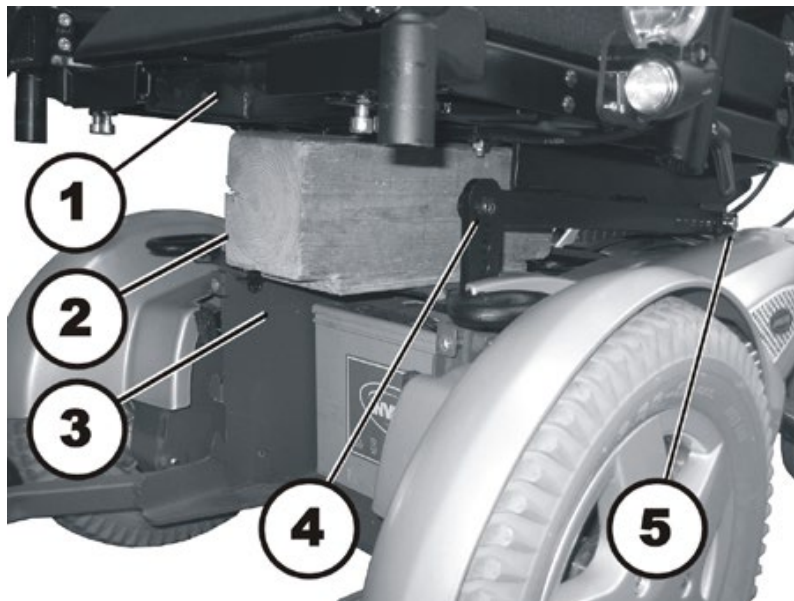

- Insert a suitable wooden block (2) between the seat (1) and the chassis (3). This will prevent the seat from falling down when you loosen and remove the screws.



WARNING: Danger of crushing!

The seat is very heavy. Danger of injury to hands and feet!

- *Use proper lifting techniques.*

-
- Use the 6 mm Allen key to loosen and remove the screws (4) on both sides in the front at the same time.
 - Hold the seat securely and loosen the rear hexagon socket head screw (5) on both sides with a 6 mm Allen key at the same time.
 - Lift the seat off.

Uninstalling the seat support (adjustable seat / simple seat)



Requirements:

- 6 mm Allen key
- 13 mm ring spanner or jaw spanner

The following figure shows the seat support with the adjustable seat plate.

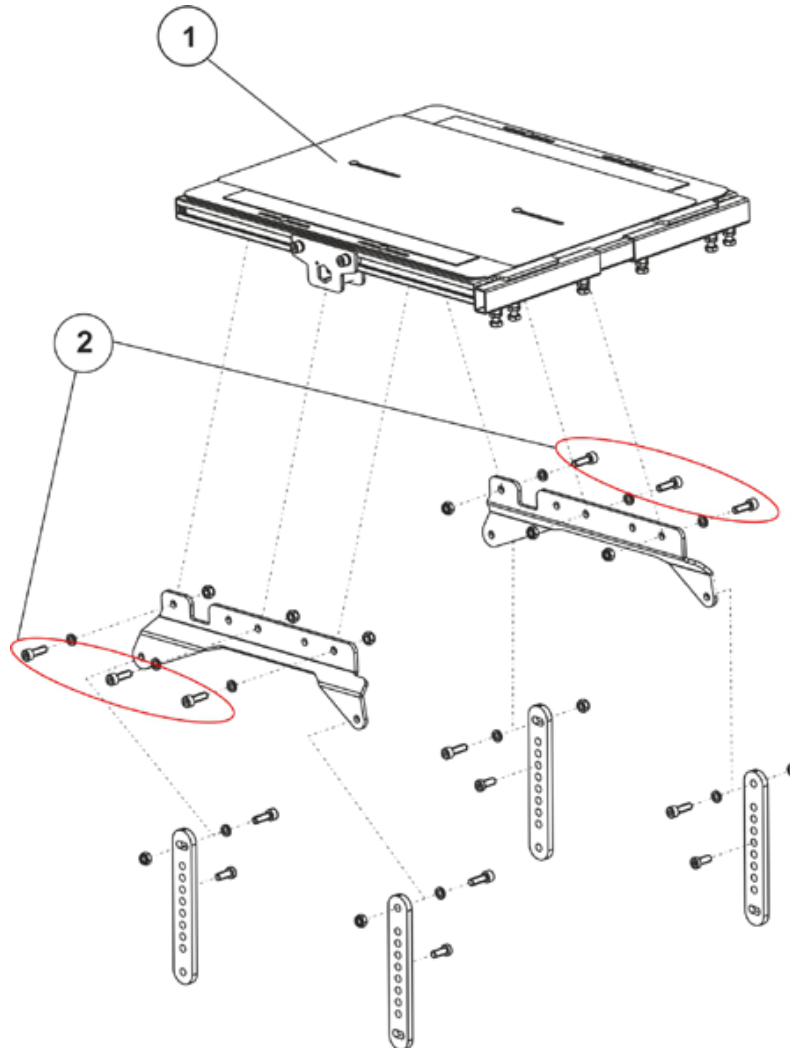

- Loosen the Allen key screws (2) with a 6 mm Allen key.
- Pull the seat frame (1) up and off.

Installing the seat and seat support

- Assemble all parts in reverse order.
- When installing the seat, pay attention to its heavy weight!
- Tighten the screws to a torque of 25 Nm.
- Check all functions of the vehicle and go for a test drive.

8.17.2 Replacing the tilt actuator



Note

Replacing the actuator for the seat angle adjustment in the lifter / seat tilt adjustment module is also described.



Requirements:

- Screwdriver, flat, width 6 mm
- 13 mm jaw spanner (2x)
- Slotted screwdriver

- Remove legrests.
- Switch the electronics OFF on the remote.
- Disconnect the actuator cable from the cable harness

Variant actuator - tilt:

- Bottom fixing bolt (3) with nut (4) –
Loose the nut with the open-ended wrenches.
Remove the nut and bolt.
- Top fixing bolt (2) secured with snap rings (1) –
Remove a snap ring using a screwdriver and
remove the bolt.
- Pull the actuator out.
- Insert a new actuator.
- Reassembly takes place in the reverse order.
- Connect the actuator cable to the cable harness.
- To complete, check all seat tilting function

Variant seat angle adjustment actuator in the lifter/seat angle adjustment module:

- Bottom fixing bolt (3) with slot –
Loosen the fixing bolt with a screwdriver.
Remove the bolt.
- Top fixing bolt (2) secured with snap rings (1) –
Remove a snap ring using a screwdriver and
remove the bolt.
- Pull the actuator out.
- Insert a new actuator.
- Reassembly takes place in the reverse order.
- Connect the actuator cable to the cable harness.
- To complete, check all seat tilting function.

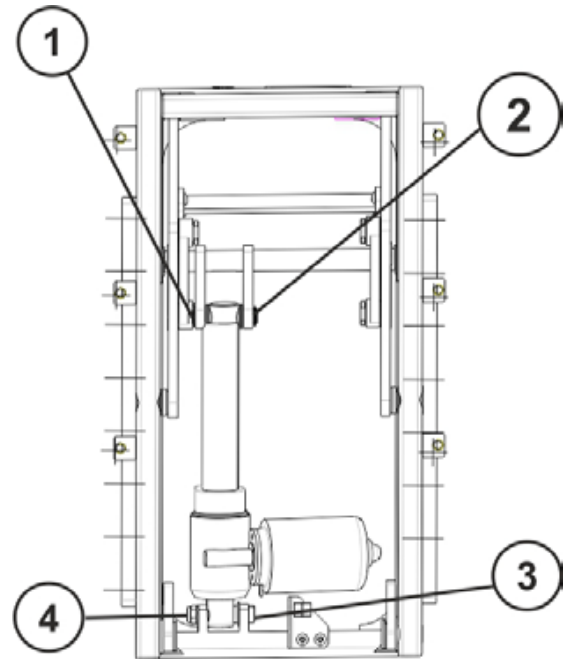

8.17.3 Replacing the lifter actuator



Requirements:

- Screwdriver flat, width 6 mm
- Large screwdriver
- Flat screwdriver

- Remove legrests.
- Run the lifter up to if possible.
- Switch the electronics OFF on the remote.
- Secure the seat.
- Pull the plug from the actuator.
- Bottom fixing bolt (2) secured with snap rings – Remove a snap ring using a screwdriver and remove the bolt.
- Top fixing bolt (3) with slot – Loosen the fixing bolt with a screwdriver. Remove the bolt.
- Replace actuator.
- Reassembly of the actuator takes place in the reverse order.
- Connect the plug of the actuator cable to the actuator.
- To complete, check all seat tilting function.

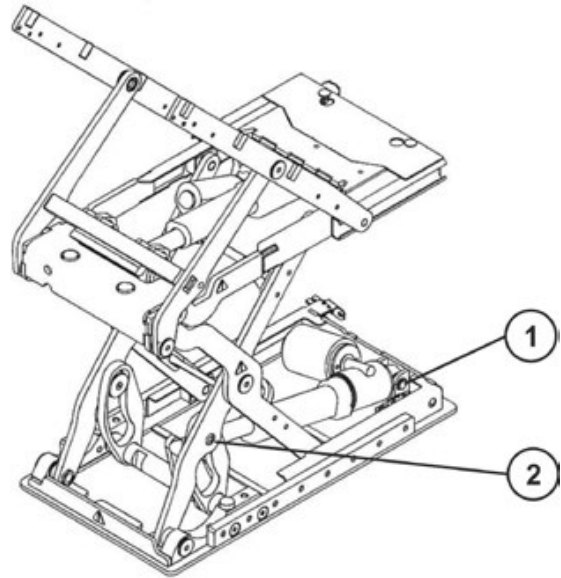

If the lifter cannot be raised, a cover can be removed from the upper rear side of the module. This way it is possible to reach the lower fixation bolt of the actuator.

8.17.4 Replacing the lifter / seat angle adjustment module



Note

Replacement of the seat angle adjustment module is performed in the same manner.



ATTENTION: Danger of crushing!

The seat/seat frame is very heavy. Danger of injury to hands and feet!

- Use proper lifting techniques



Requirements:

- 3 mm Allen key
- 5 mm Allen key
- T25 Torx wrench
- T40 Torx wrench
- Side cutting pliers
- Cable ties

- Remove legrests.
- Tilt the seat tilting completely to the rear if possible.
- Switch the electronics OFF on the remote.
- Remove the backrest cushion.
- Loosen and remove the screws, which secure the middle seat plate (A) with a 3 mm Allen key.
- Remove the middle seat plate (B).
- Loosen and remove the screws on both sides, which secure the lateral seat plates (C) with a 3 mm Allen key.
- Remove the lateral seat plates (D).
- or**
- Remove the seat cushion.
- Loosen and remove the screws on both sides, which secure the sling seat (A) with a T25 Torx wrench.
- Remove the sling seat (B).

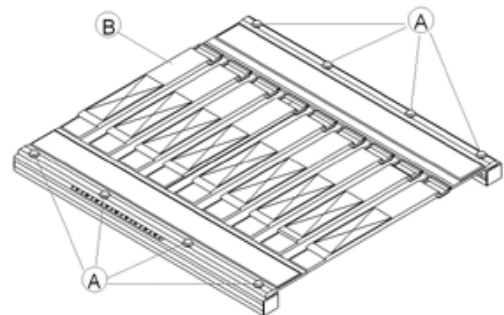
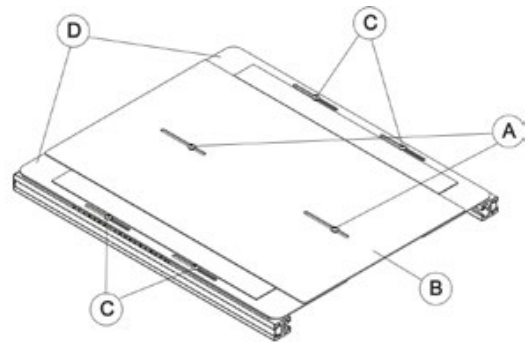

- Remove the seat frame by removing the screws (1) with a T40 Torx wrench.

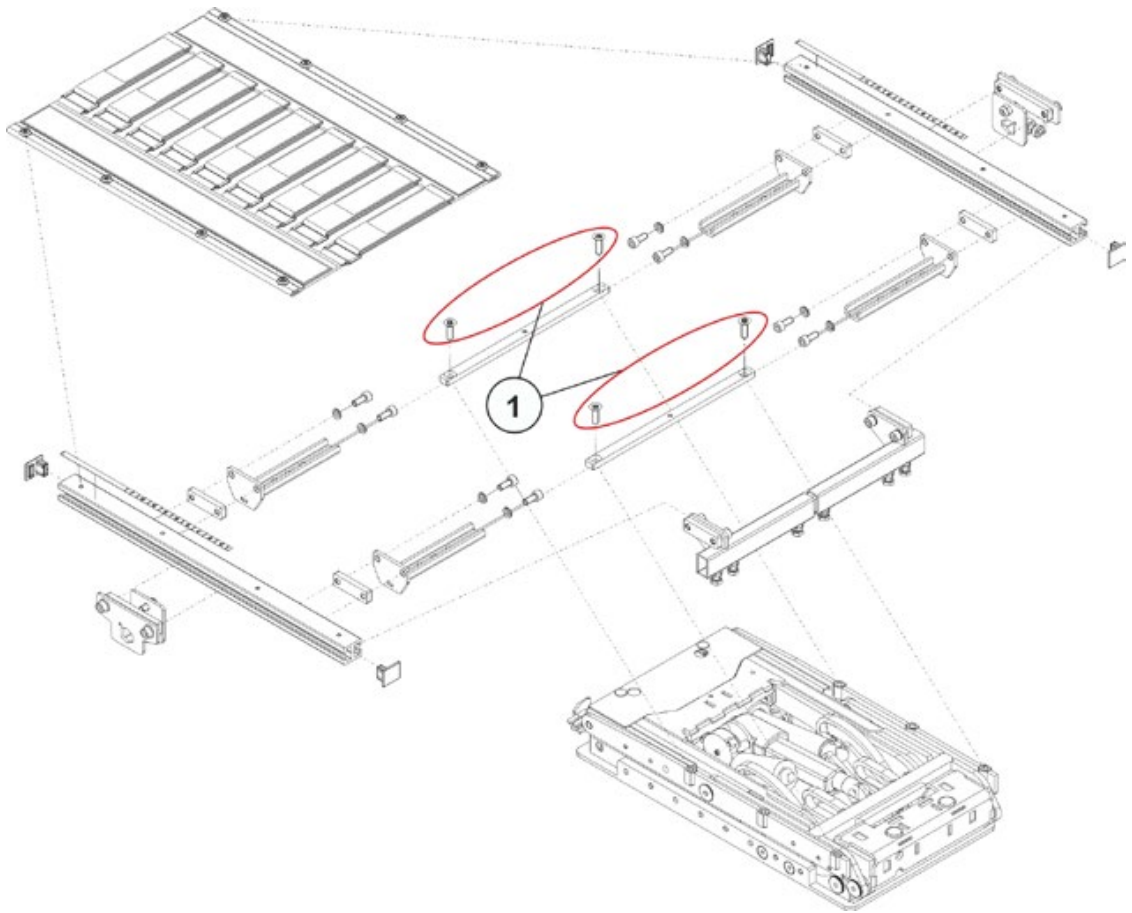

- Disconnect the actuator cable and microswitch cable from the cable harness.

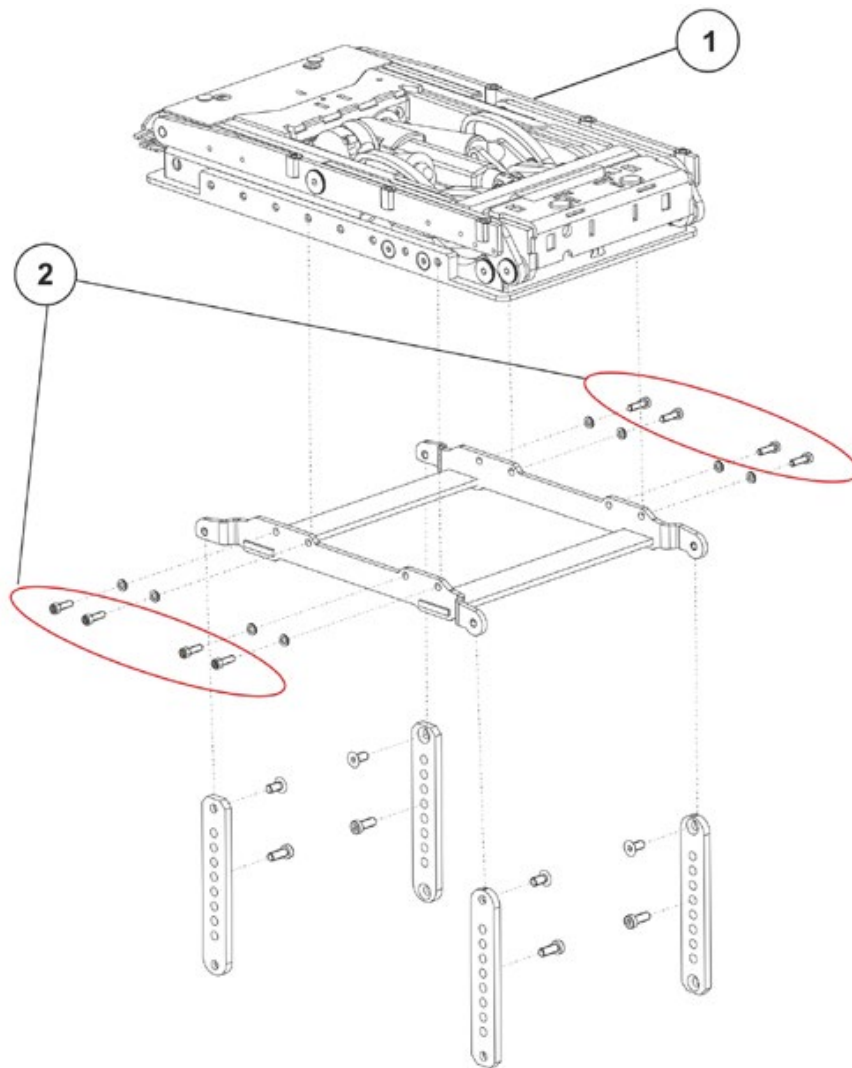

- Loosen and remove the screws (2) incl. the washers with a 5 mm Allen key.
- Lift the module of the seat angle adjustment (1) from the adapter and replace it.
- Reassembly takes place in the reverse order.

**Note**

Make sure that all screws, washers and nuts are reassembled in the correct order and securely tightened during assembly.

- To complete, check all seat tilting function.

8.17.5 Replacing the backrest actuator

Dismantling the backrest actuator:

- Pull the cable off directly where it is connected to the actuator (1)
- Detach the bracket of the actuator at the top and bottom; to do this, slide the bolts (3) to the side using the lever (4) and tilt the actuator (1) out of the backrest clamp (2).
- Replace actuator.

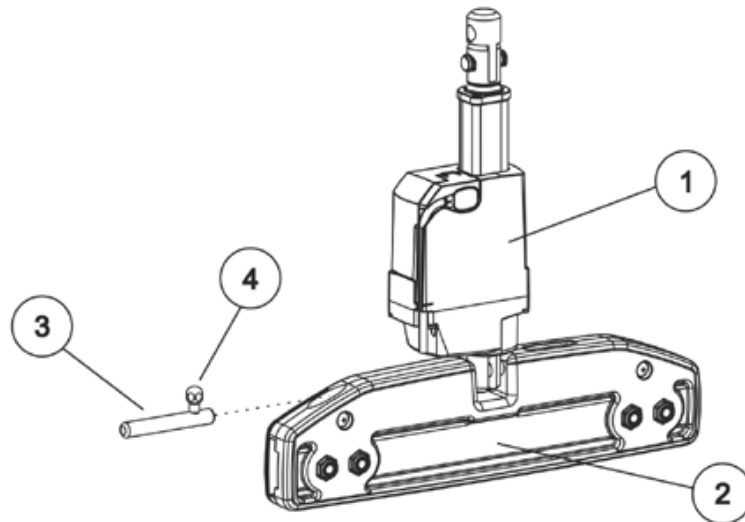

Refitting the backrest actuator:

- Assemble the parts in the reverse order.

8.18 Backrest Module

8.18.1 Replacing the standard backrest



Requirements:

- 5 mm Allen key

Dismantling the backrest unit:

- Remove the backrest cushion.
- Loosen the fixation lever (2) of the backrest tube.
- Remove the backrest tube.

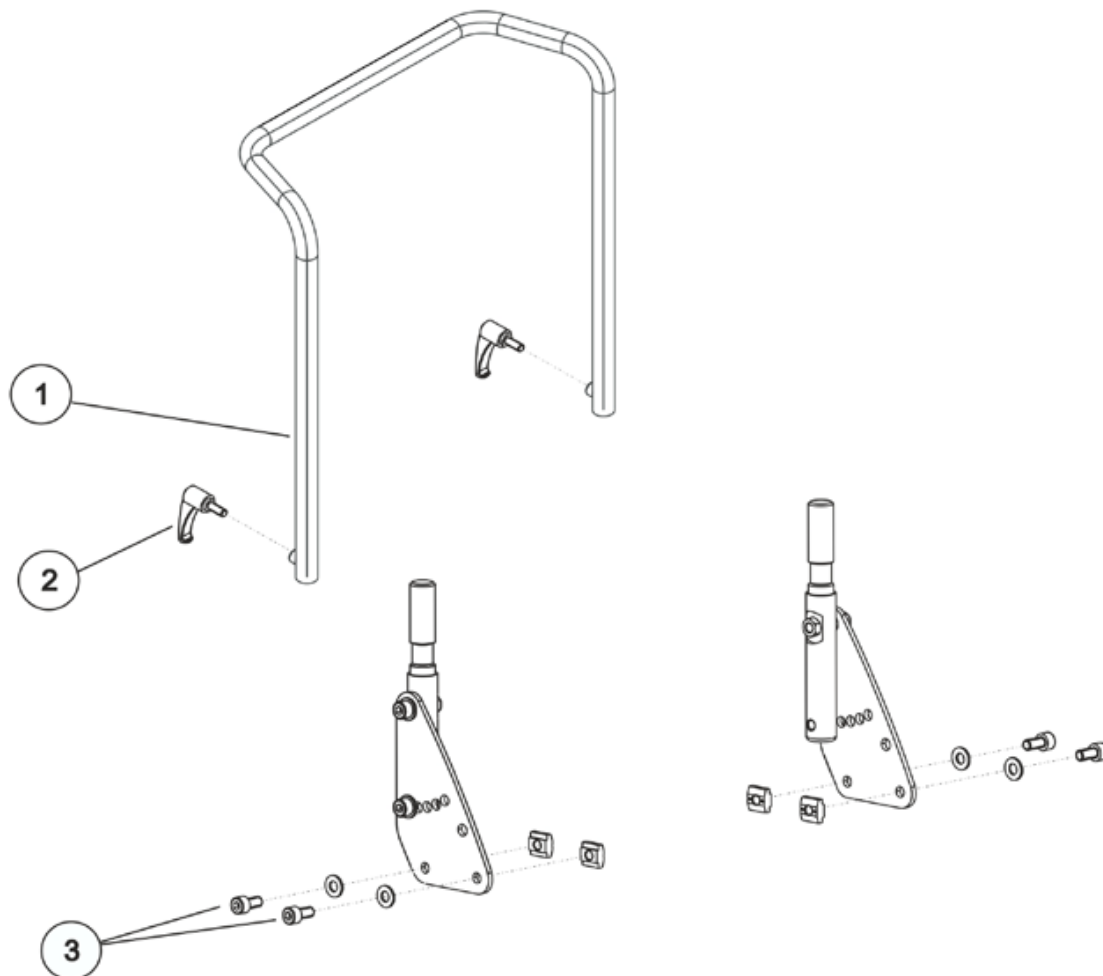

- Use the Allen key to loosen and remove the hexagon socket head screws (3) including the nuts and washers on the left and right side of the chair.

Refitting the backrest unit:

- Replace the parts in the reverse order.
- To conclude, you should always carry out a trial run to test the vehicle functions.

8.18.2 Replacing the backrest mounting bracket



Requirements:

- 5 mm Allen key

Dismantling the backrest unit:

- Remove the backrest cushion.
- Loosen the fixation levers (2) of the corresponding backrest tube (1), depending on the version.

There are two versions:

(2) - for the manual backrest

(3) - for the electrically adjustable backrest

- Remove the backrest tube.

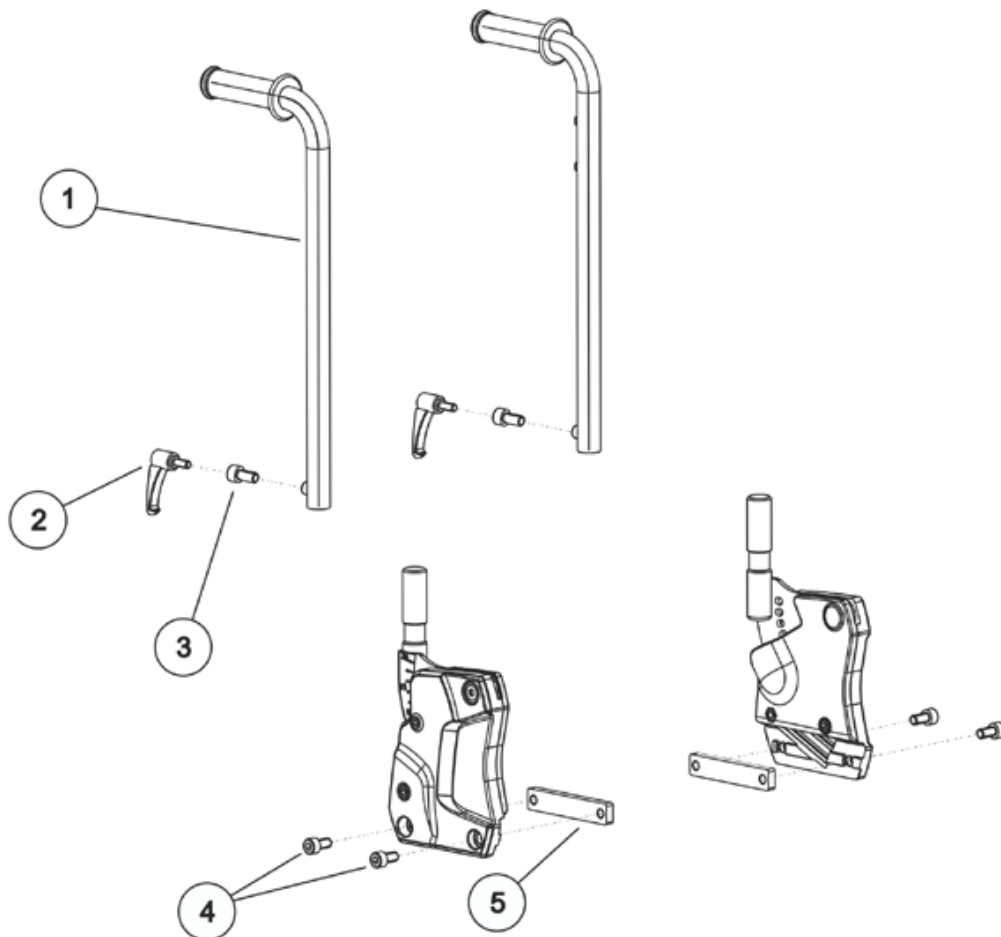

- Loosen and remove the two hexagon socket head screws (4) to the sliding block (5) on the left and right side of the chair.

Refitting the backrest unit:

- Replace the parts in the reverse order.
- To conclude, you should always carry out a trial run to test the vehicle functions.

8.18.3 Replacing the backrest mounting bracket for SB 53



Requirements:

- 5 mm Allen key

Dismantling the backrest unit:

- Remove the backrest cushion.
- Loosen the fixation levers (2) of the corresponding backrest tube (1), depending on the version.

There are two versions:

(2) - for the manual backrest

(3) - for the electrically adjustable backrest

- Remove the backrest tube.

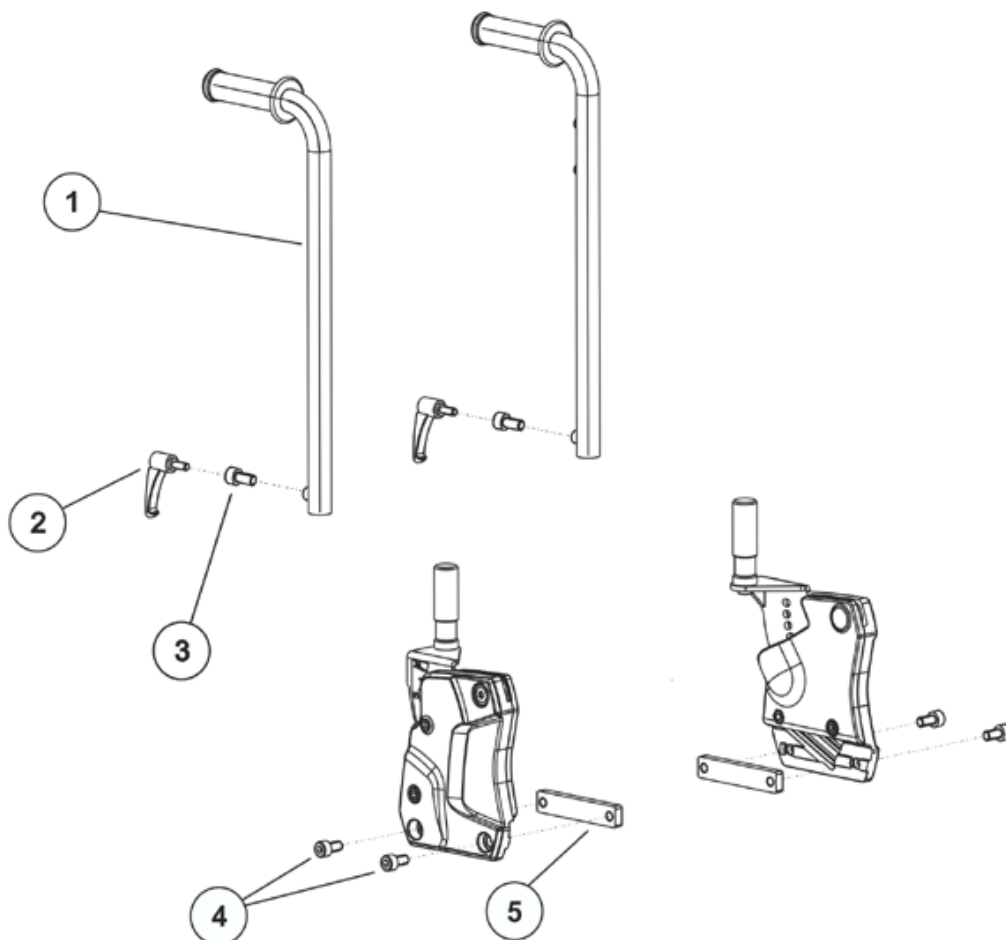

- Loosen and remove the two hexagon socket head screws (4) to the sliding block (5) on the left and right side of the chair.

Refitting the backrest unit:

- Replace the parts in the reverse order.
- To conclude, you should always carry out a trial run to test the vehicle functions.

8.18.4 Adjusting the seat width/ backrest width

8.18.4.1 Adjusting the seat width

You can only adjust the seat width for the adjustable seat plate or for the adjustable sling seat.

The sling seat is available in two widths:

- for a seat width of 38-43 cm and
- for a seat width of 48-53 cm.

When modifying the seat width, the backrest width must also be correspondingly adapted. See chapter 8.18.4.3.



Requirements:

- 3 mm Allen key
- 5 mm Allen key
- 13 mm open-ended spanner
- T25 Torx wrench
- T40 Torx wrench

- Remove the backrest cushion.
- Remove the backrest from the backrest mounting bracket.
See chapter 8.18.
- Loosen and remove the screws, which secure the middle seat plate (A) with a 3 mm Allen key.
- Remove the middle seat plate (B).
- Loosen and remove the screws on both sides, which secure the lateral seat plates (C) with a 3 mm Allen key.
- Remove the lateral seat plates (D).
- or**
- Remove the seat cushion.
- Loosen and remove the screws on both sides, which secure the sling seat (A) with a T25 Torx wrench.
- Remove the sling seat (B).

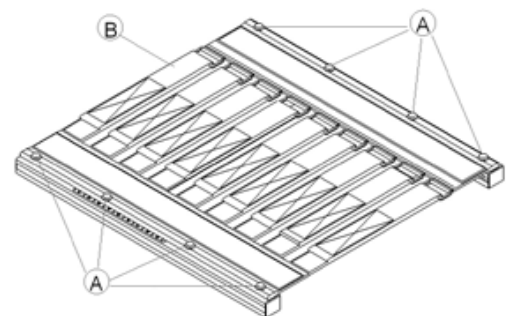
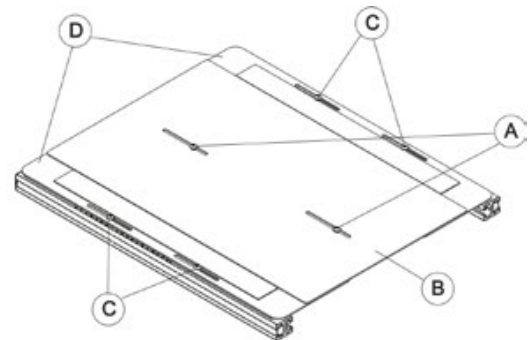

- Loosen and remove the screws of the seat frame adjustment (A) with a T40 Torx wrench.
- Loosen and remove the screws of the fixation of the legrest mounting brackets (B).

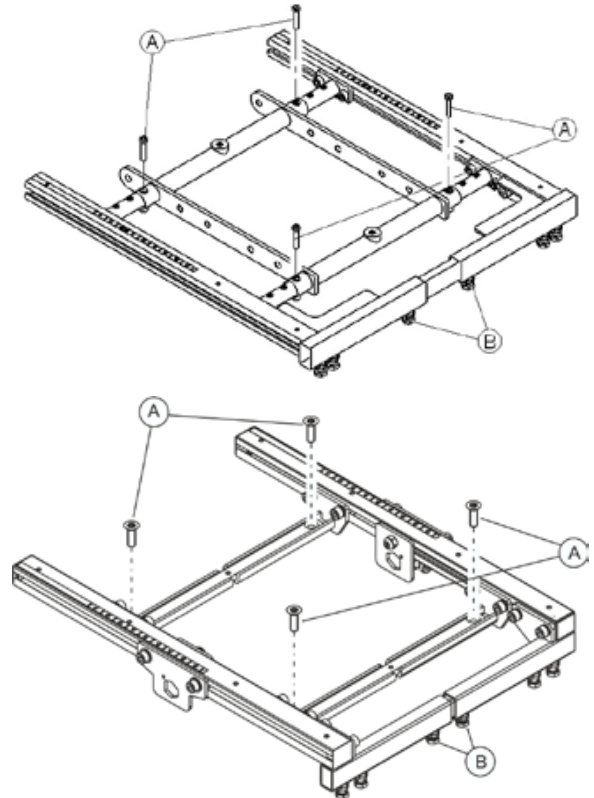

- Adjust the seat frame and the legrest fixation to the desired width according to the following illustrations and tables:

Seat frame:

Screw position	Seat width
A	530 mm
B	480 mm
C	430 mm
D	380 mm

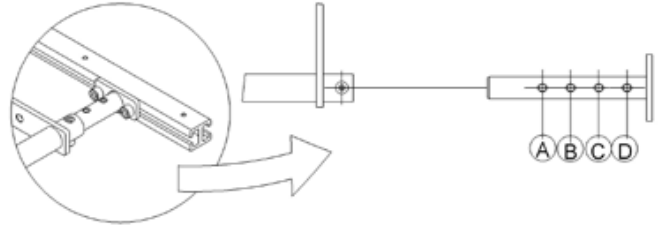

Leg supports connection:

Screw position	Seat width
A	380 mm
B	430 mm
C	480 mm
D	530 mm

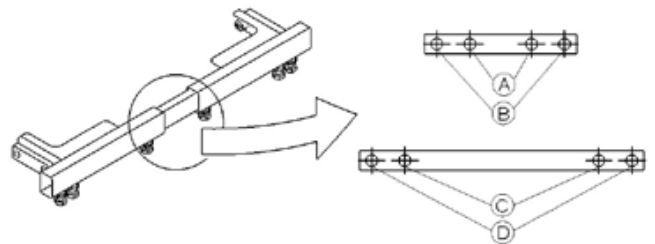

Note

When switching from 430 mm to 480 mm and the other way around, the fixation of the legrests must be replaced.

- Reposition the screws and tighten them again.
- Install the seat plate or the sling seat.
- Reposition the seat cushion.

8.18.4.2 Adjusting the seat width (legrest LNX)

You can only adjust the seat width for the adjustable seat plate or for the adjustable sling seat. At the legrest LNX, the seat width is adjusted with the seat frame.

The sling seat is available in two widths:

- for a seat width of 38-43 cm and
- for a seat width of 48-53 cm.

When modifying the seat width, the backrest width must also be correspondingly adapted. See chapter 8.18.4.3.



Requirements:

- 3 mm Allen key
- 5 mm Allen key
- 13 mm open-ended spanner
- T25 Torx wrench
- T40 Torx wrench
- 4 mm Allen key (legrest LNX)
- 10 mm ring spanner or jaw spanner (legrest LNX)

- Remove the backrest cushion.
- Remove the backrest from the backrest mounting bracket. See chapter 8.18.
- Loosen and remove the screws, which secure the middle seat plate (A) with a 3 mm Allen key.
- Remove the middle seat plate (B).
- Loosen and remove the screws on both sides, which secure the lateral seat plates (C) with a 3 mm Allen key.
- Remove the lateral seat plates (D).

or

- Remove the seat cushion.
- Loosen and remove the screws on both sides, which secure the sling seat (A) with a T25 Torx wrench.
- Remove the sling seat (B).

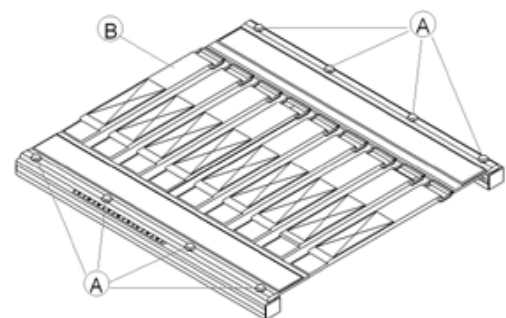
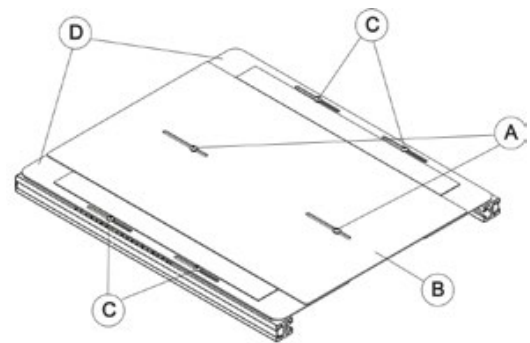

With the legrest LNX, the seat width is set directly via the seat frame because the LNX bracket is attached directly to the seat profile.

- To adjust the seat width, loosen and remove the screws of the seat frame adjustment (A) with a T40 Torx wrench. See table on p. 163.
- With the LNX bracket, use the outer drill hole (B) to adjust the corresponding width for the legrest fixation LNX of the seat width.

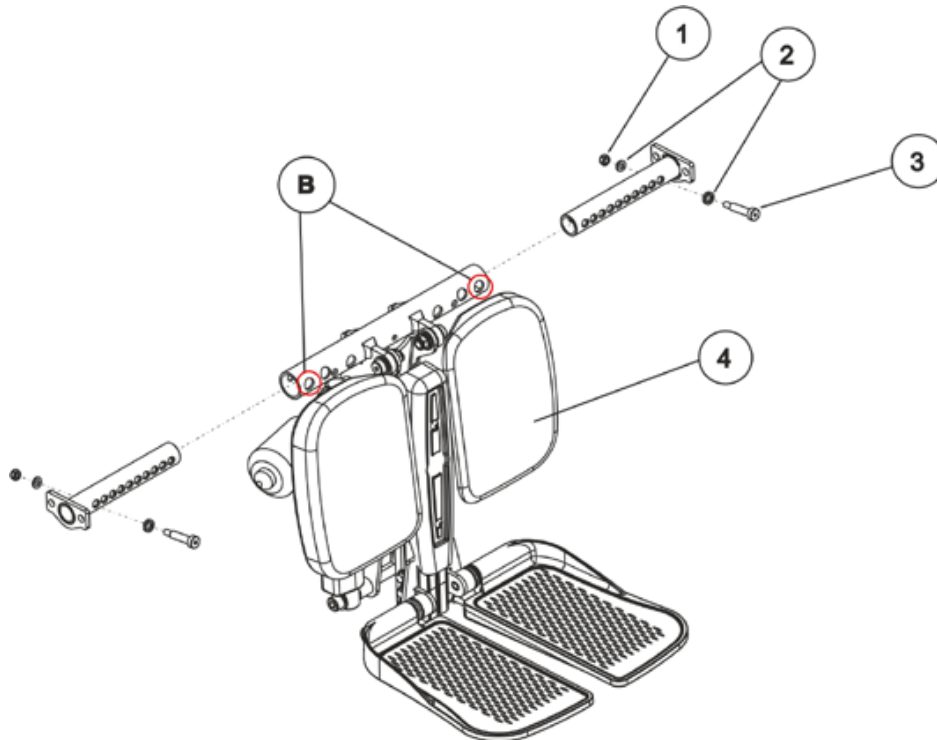
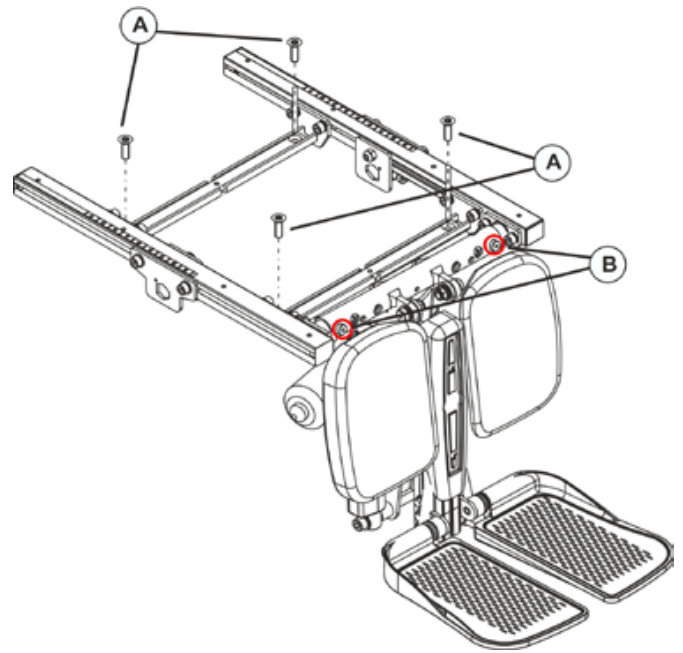

- Loosen and remove the screws (3) include the washers (2) and the nut (1) on the left and right side.
- Adjust to the desired seat width.
- Reposition the screws and tighten them again.
- Install the seat plate or the sling seat.
- Reposition the seat cushion.

8.18.4.3 Adjusting the backrest width

The backrest width is adjusted by performing the following tasks:

- Adjust the backrest tube.
- Adjust the backrest:
 - Sling backrest, as described in chapter 8.15.2.
 - Flex3 backrest, as described in chapter 8.18.4.4.
- Replace the backrest cushion (these are available in various widths).

When modifying the backrest width, the seat width must also be correspondingly adapted. Please see chapter 8.18.4.1.



Requirements:

- 3 mm Allen key
- 5 mm Allen key
- 13 mm Open-ended spanner

The screw position for the backrest width, refer to the table:

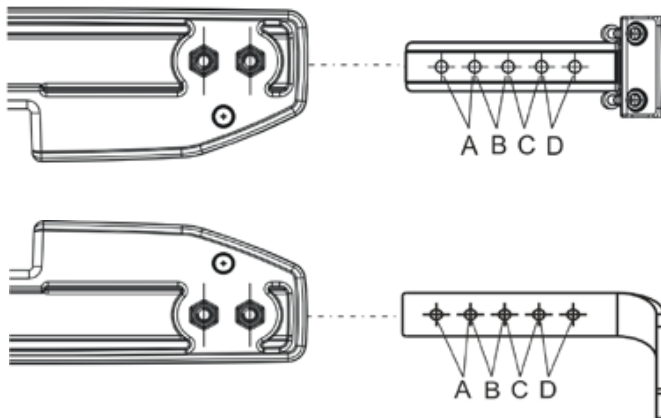

Screw position	Seat width
A	530 mm
B	480 mm
C	430 mm
D	380 mm

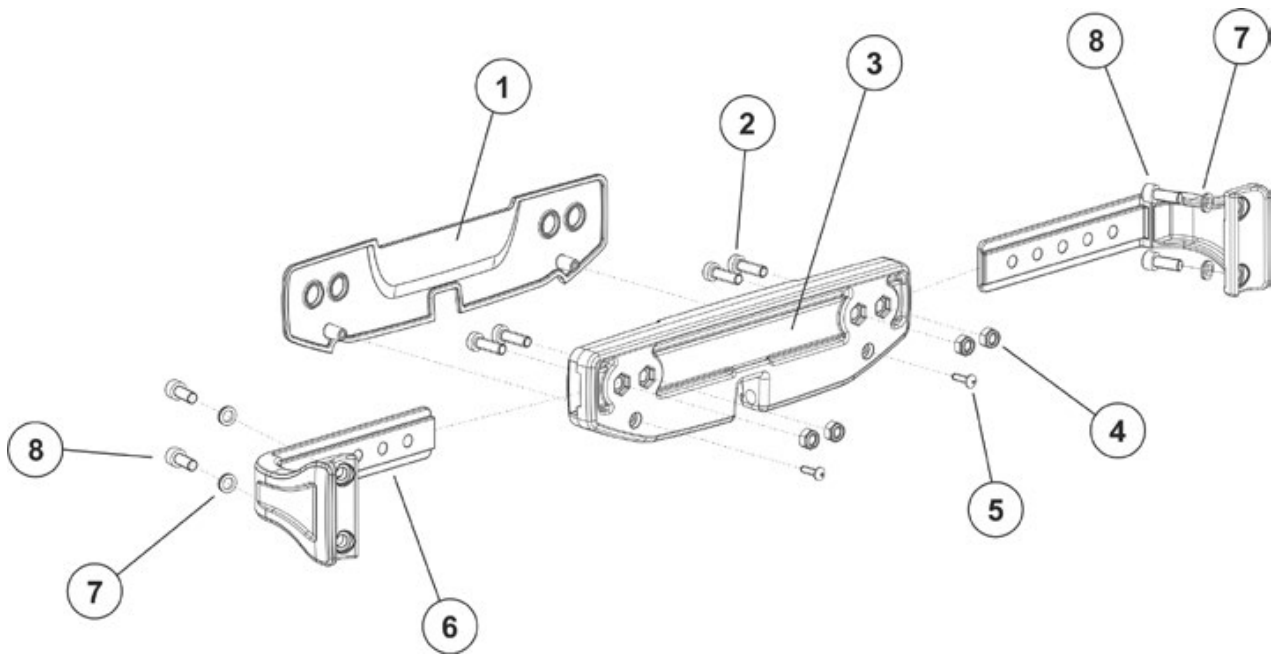

- Remove the backrest cushion.
- Loosen the straps of the sling backrest or remove the Flex3 backrest.
- Loosen and remove both screws (5) of the actuator fixation bracket.
- Remove the cover of the actuator fixation bracket.
- Loosen and remove the screws and nuts (2, 4) on the upper and lower actuator fixation bracket on both sides.
- Adjust the backrest fixation (6) for the new backrest width according to the table on page 166.
- Insert the screws (2) through the cover of the actuator fixation bracket and the corresponding holes of the backrest fixation to the actuator fixation.
- Fasten these with the nuts (4).
- Reposition the cover of the actuator fixation bracket.
- Insert and tighten the screws (5) again.
- Adjust the straps of the sling backrest to the new width or install the adjusted Flex 3 backrest.
- Install the backrest cushion.
- Perform a function check of the chair.

8.18.4.4 Adjusting the Flex3 backrest



Requirements:

- Phillips screwdriver
- 5 mm Allen key

- Remove the front lateral plates (2 and 4) from the backrest (1) by loosening and removing the five hexagon socket head screws (3).

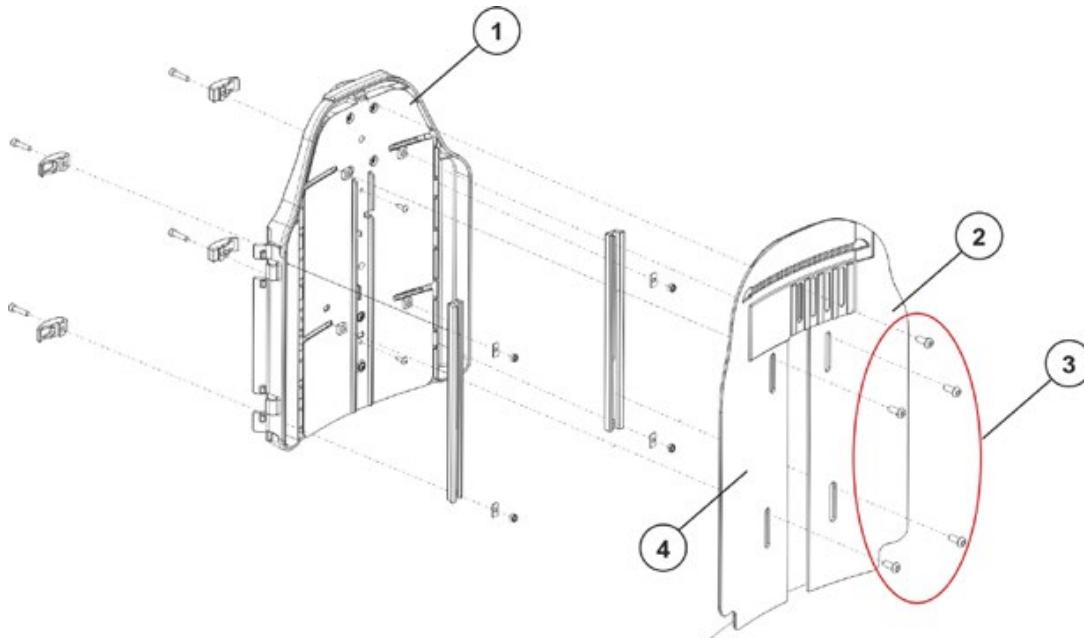

- Remove both Phillips screws (A) on the middle plate.

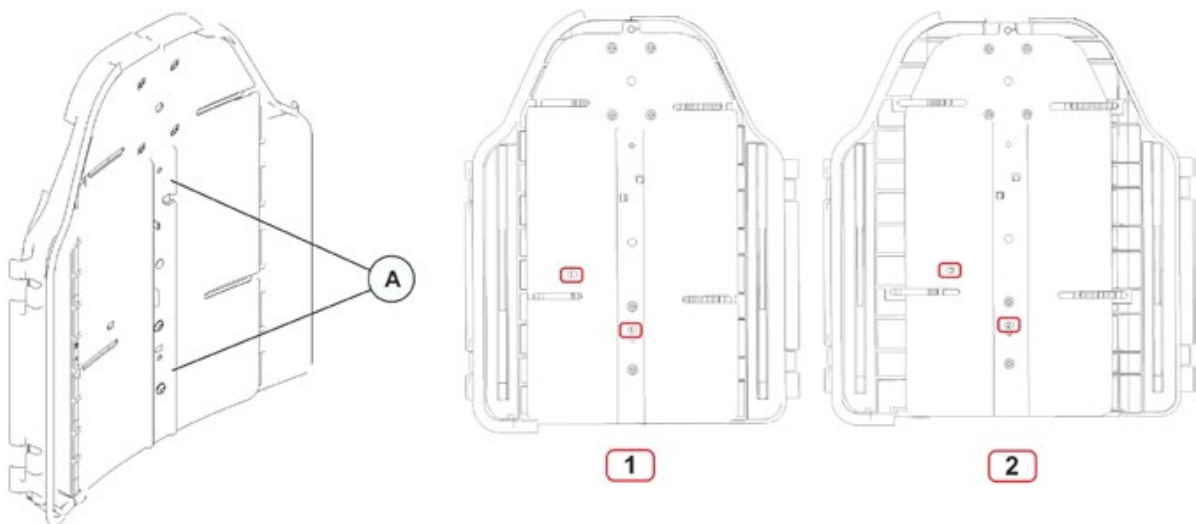

- Shift the position of the rear plate halves (three settings are possible using the drill holes).
 - **Before** pulling the Flex3 backrest apart, a "1" will be visible in the small, rectangular cut-out.
 - **After** pulling the Flex3 backrest apart, a "2" will be visible in the small, rectangular cut-out.
- Re-insert the two screws (A) into the middle plate.
- Fasten the front lateral plates (2 and 4) again.

8.19 Fixation rings

8.19.1 Replacing a front fixation ring

**Requirements:**

- 13 mm socket wrenches (two of them)
- Torque wrench 0 – 30 Nm (or similar)

Removing a front fixation ring:

- Switch the wheelchair off.
- Remove the front cover and the rear covers, as described in chapters 8.1.1 and 8.1.2.
- Remove the seat, as described in chapter 8.13 or 8.17.

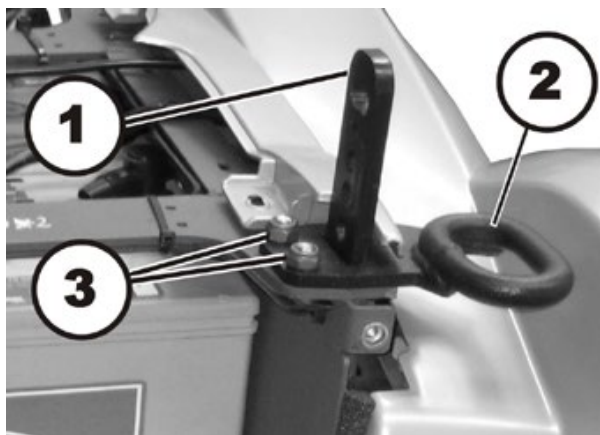

- Loosen and remove both of the self-locking nuts (3).
- Pull the fixation ring (2) up and off of the seat frame (1).

Installing a front fixation ring:

- Assemble all parts in reverse order.
- Tighten the screws (3) to a torque of 25 Nm.
- When installing the seat, pay attention to its heavy weight!
- When installing the seat, pay attention to the adjustment settings of the seat tilt.
- Check all functions of the vehicle and go for a test drive.

8.19.2 Replacing a rear fixation ring

**Requirements:**

- 13 mm socket wrenches (two of them)
- Torque wrench 0 – 30 Nm (or similar)

Removing a rear fixation ring:

- Switch the wheelchair off.
- Remove the front cover and the rear covers, as described in chapters 8.1.1 and 8.1.2.

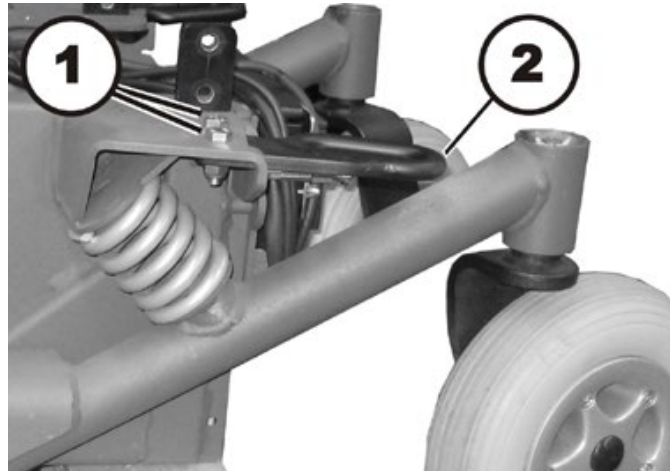

- Use both 13 mm socket wrenches to loosen and remove both screws (1).
- Pull the fixation ring (2) backwards out of the bracket.

Installing a rear fixation ring:

- Assemble all parts in reverse order.
- Tighten the screws (1) to a torque of 25 Nm.
- Check all functions of the vehicle and go for a test drive.

9 Installing accessories

9.1 Replacing the restraining belt

**Requirements:**

- 10 mm socket wrench
- 4 mm Allen key

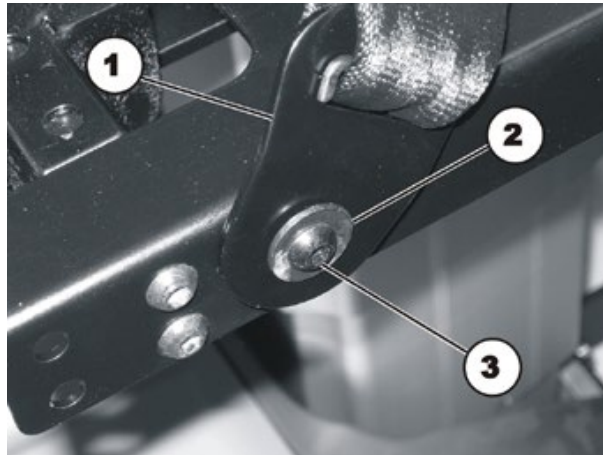
**Uninstalling the restraining belt:**

- Loosen the screw (3) and the corresponding nut (not shown in the illustration) with a 4 mm Allen key and a 10 mm socket wrench.
- Remove the nut including the washer.
- Remove the screw together with the restraining belt and the washer (2) and also the washer behind it.

**Note**

Another nut is used between the washers as a spacer, so that the belt bracket can move freely.

- Replace the restraining belt (1).

Installing the restraining belt:

- Assemble the parts in reverse order.

9.2 Replacing the harness belt

**Requirements:**

- 10 mm socket wrench
- 4 mm Allen key

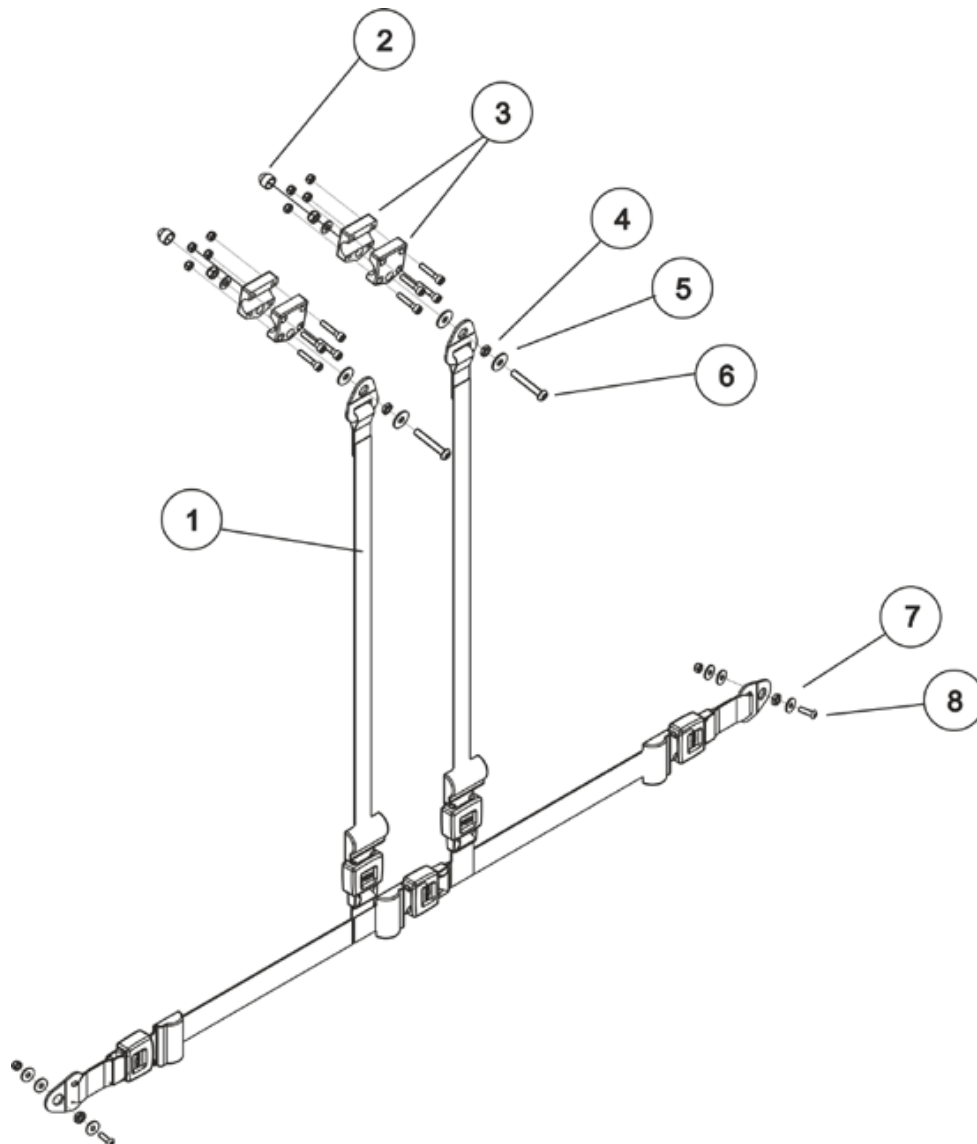
**Uninstalling the harness belt:**

- Remove the protective cap (2).
- Loosen and remove the screw (6), the associated washers (5) and the nuts (4) (in front of the/behind the gripper clamp (3)) with a 4 mm Allen key and a 10 mm socket wrench.
- Loosen and remove the screw (8), the associated washers (7) in the lower part of the harness belt (1) with a 4 mm Allen key and a 10 mm socket wrench.

**Note**

Another nut is used between the washers as a spacer, so that the belt bracket can move freely.

- Replace the harness belt (1).

Installing the harness belt:

- Assemble the parts in reverse order.

9.3 Replacing seat belts (Modulite seat)

9.3.1 Installation on the backrest mounting bracket (simple backrest)

**Requirements:**

- 13 mm Socket spanner
- 5 mm Allen key

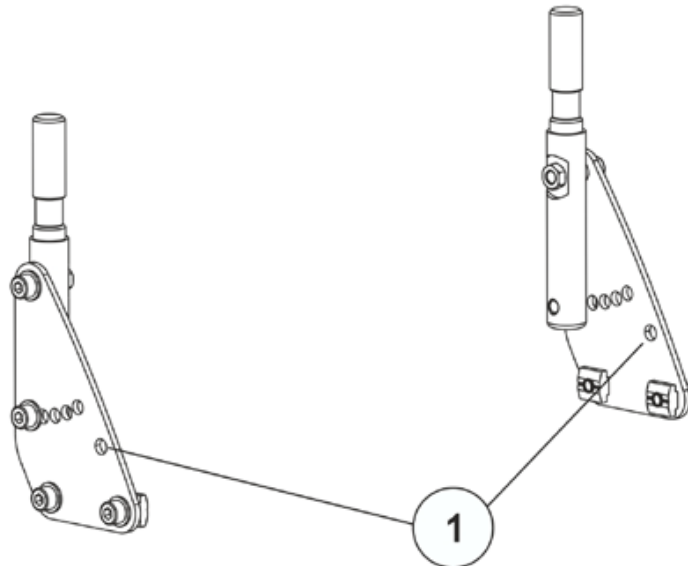

- The seat belts are attached via the drill hole (1) at the top right.
- The installation of seat belts is described in chapter 9.1.

9.3.2 Installation on the backrest mounting bracket (adjustable seat)

**Requirements:**

- 5 mm Allen key

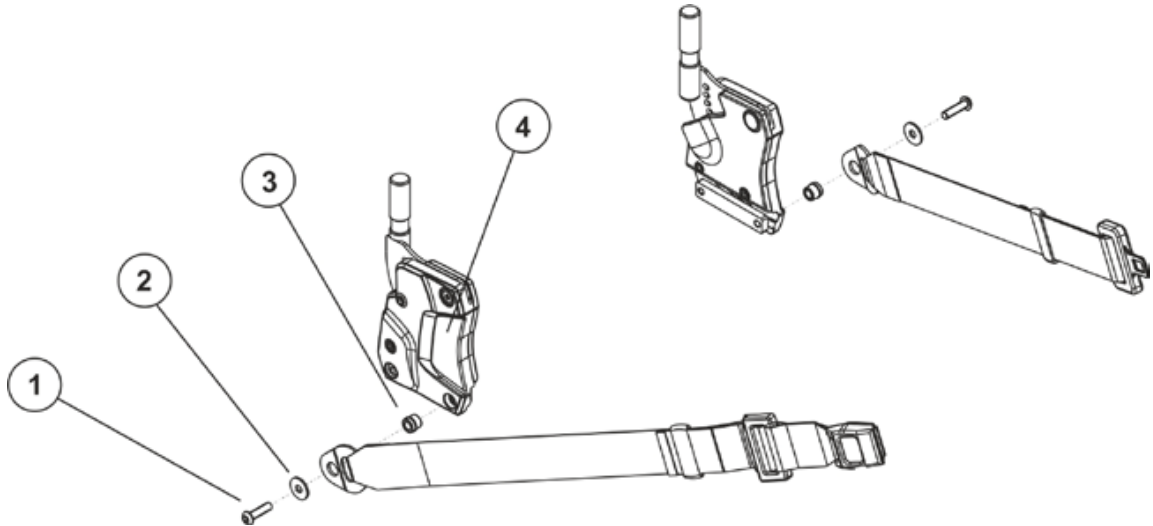

- Loosen the screw (1) with a 5 mm Allen key.
- Remove the screw (1), the corresponding washer (2) and the seat belt and belt winder (3) from the backrest mounting bracket (4).
- Replace the safety belt.
- Refit the parts in the reverse order.

9.3.3 Installation on the seat frame profile (adjustable seat)

**Requirements:**

- 5 mm Allen key

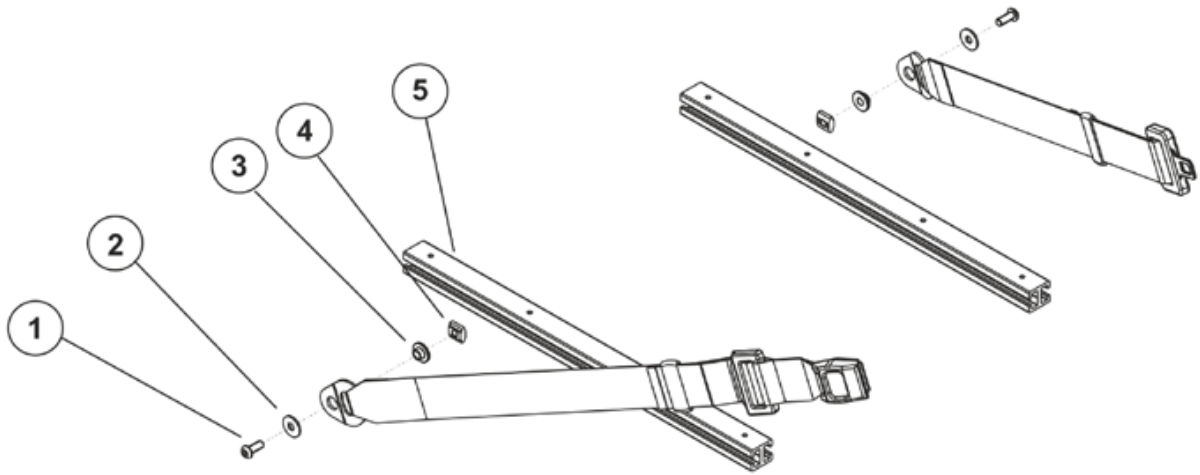

- Loosen the screw (1) with a 5 mm Allen key.
- Remove the screw (1), the washer (2), the seat belt, the sliding bushing (3) and the sliding block (4) from the seat frame profile (5).
- Replace the safety belt.
- Refit the parts in the reverse order.

9.3.4 Replacing the harness belt (adjustable seat)

**Requirements:**

- 13 mm socket wrench
- 5 mm Allen key

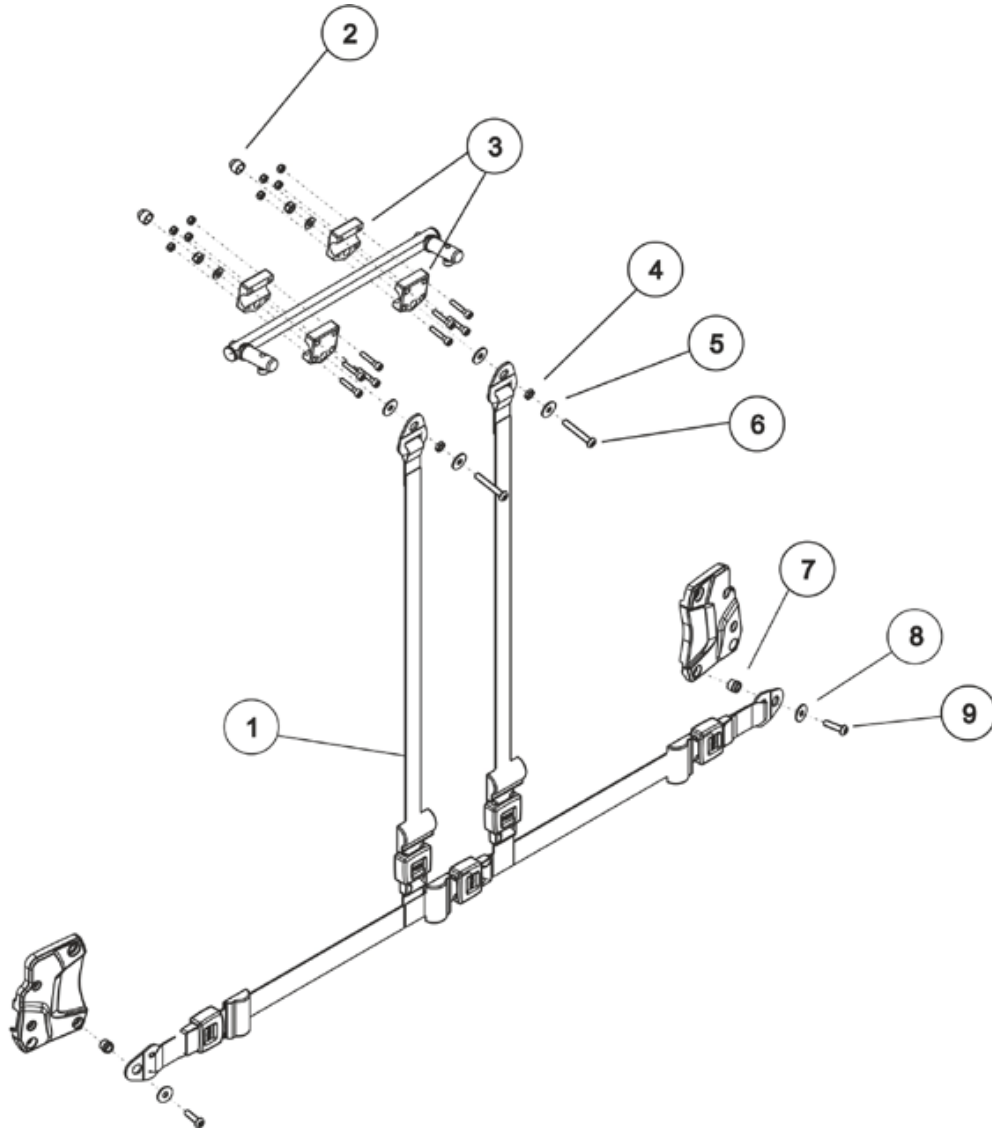
**Uninstalling the harness belt:**

- Remove the protective cap (2).
- Loosen and remove the screw (6), the associated washers (5) and the nuts (4) (in front of the/behind the gripper clamp (3)) with a 5 mm Allen key and a 13 mm socket wrench.
- Loosen and remove the screw (9), the associated washer (8) and the belt winder (7) in the lower part of the harness belt (1) with a 5 mm Allen key.

**Note**

A belt winder is mounted, so that the belt bracket can move freely.

- Replace the harness belt (1).

Installing the harness belt:

- Assemble the parts in reverse order.

9.3.5 Replacing the harness belt (simple seat)

**Requirements:**

- 13 mm socket wrench
- 5 mm Allen key

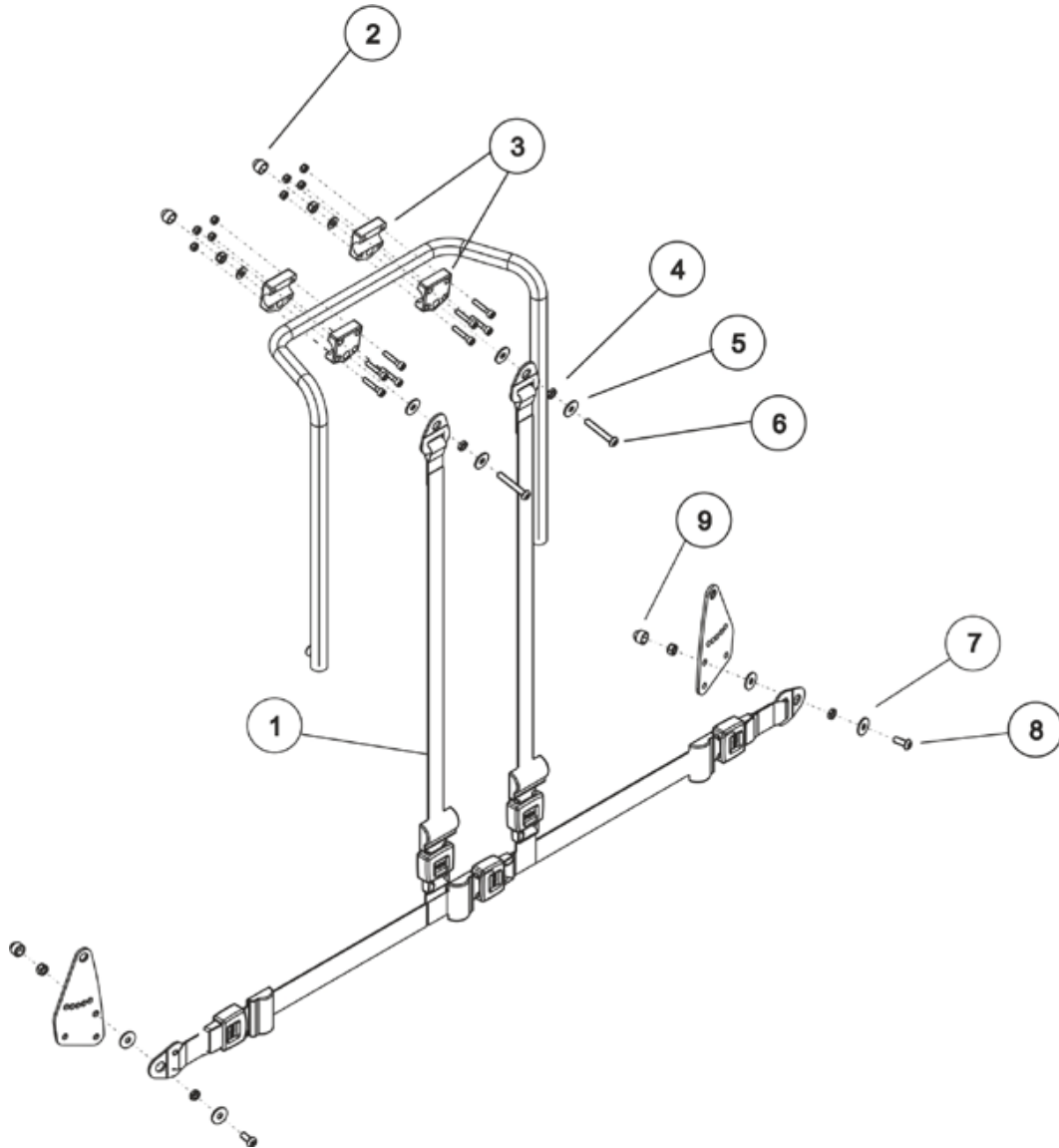
**Uninstalling the harness belt:**

- Remove the protective cap (2).
- Loosen and remove the screw (6), the associated washers (5) and the nuts (4) (in front of the/behind the gripper clamp (3)) with a 5 mm Allen key and a 13 mm socket wrench.
- Remove the protective cap (9).
- Loosen and remove the screw (8), the associated washers (7) and the nuts in the lower part of the harness belt (1) with a 5 mm Allen key and a 13 mm socket wrench.

**Note**

Another nut is used between the washers as a spacer, so that the belt bracket can move freely.

- Replace the harness belt (1).

Installing the harness belt:

- Assemble the parts in reverse order.

9.4 DAHL Docking Station



CAUTION: Danger of crushing!

The mobility device is very heavy. Injury hazard to hands and feet!

- Use proper lifting techniques.

Injury hazard caused by uncontrolled movement of the mobility device!

- Switch the power supply off (ON/OFF key).
- Engage the drive.
- Position the mobility device on it's side and secure the position so it does not turn over.



Requirements:

- 6 mm Allen key
- high-strength screw blocker system, e.g. Loctite 270

For unprepared wheelchair additional:

- 4 mm Allen key
- 5 mm Allen key

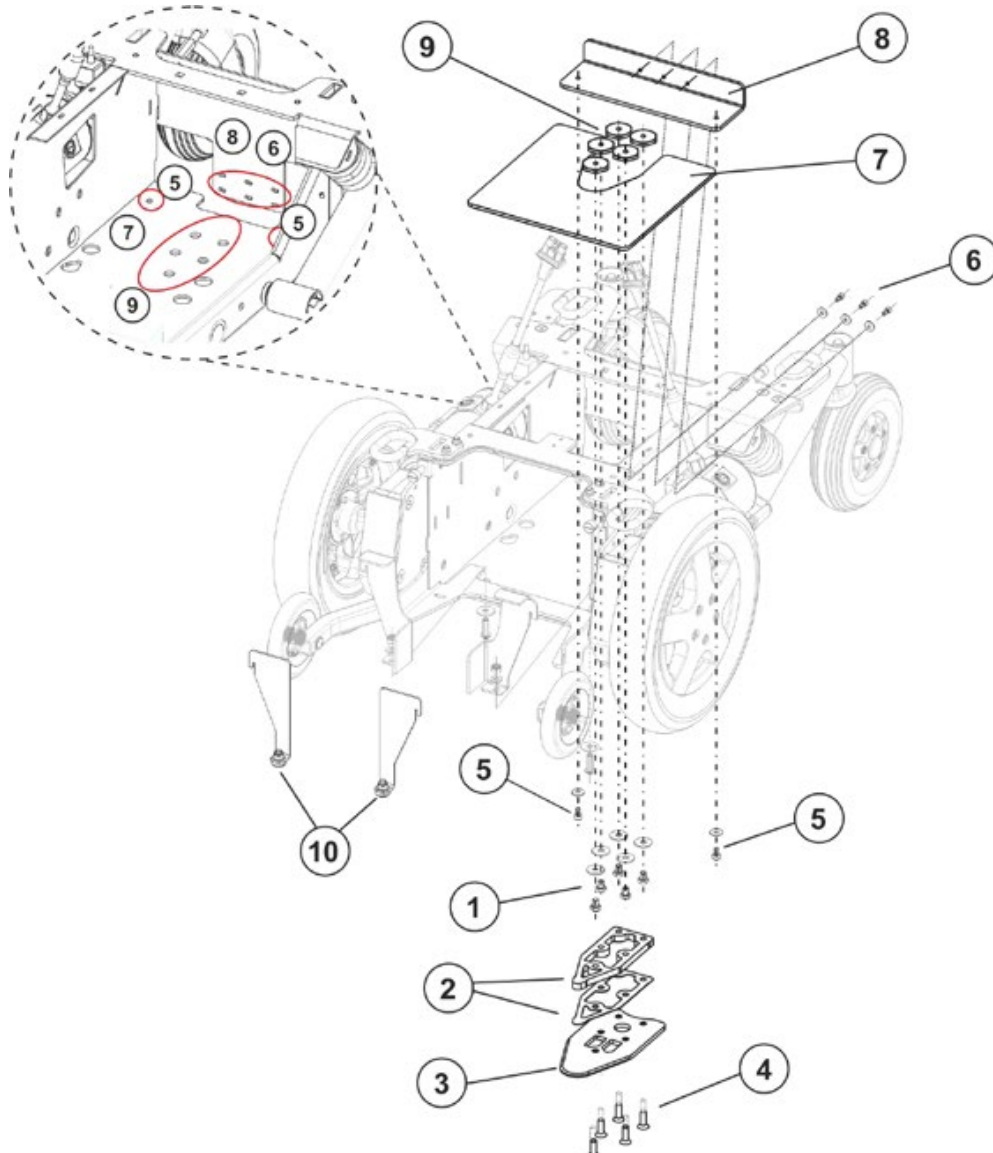

**Note**

Depending on the vehicle, several spacers (2) may be required in addition to the safety plate (3). Please refer to the documentation provided by DAHL (see also www.dahlengineering.dk) for information on whether and how many spacers are required.

**Note**

The countersunk screw (4) material quality must be at least 8.8.
If spacers have been fitted, the screws length should be completed as follows:
A = thickness of safety plate and spacers

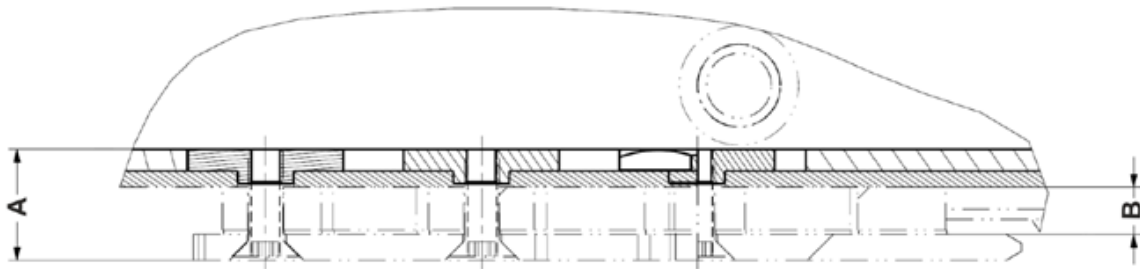

A = -1 mm Screw length

B = Height of spacers

**Note**

When installing the plates, ensure the correct screw length (A -1 mm) is used.
Longer screws could damage the batteries.

Fitting the DAHL Docking Station (prepared wheelchair):

- Remove the legrests.
- Remove the front cover, as described in chapter 8.1.1.
- Remove the batteries, as described in chapter 8.4.1.
- Jack up the mobility aid using several wooden blocks. Use proper lifting techniques.
- Loosen and remove the five bolts (1) including the washers on the underside of the chassis.
- Calculate the required screw length in accordance with the above formula.
- Select five M8 Allen key countersunk screws (4) in accordance with DIN 7991 (material quality at least 8.8) to suit the calculated length.
- Fit the spacers (2) and the safety plate (3) over the drillholes with the special nuts (9).
- Fit the Allen screws (4) with a high-strength screw blocker system such as Loctite 270.
- Fit the batteries, as described in chapter 8.4.1.

**Note**

Fit new retaining plates (10) including screws and washers.

- Fit the remaining parts in the reverse order.
- To conclude, check all fittings for secure connection.

Fitting the DAHL Docking Station (unprepared wheelchair):

- Remove the legrests.
- Remove the front cover, as described in chapter 8.1.1.
- Remove the batteries, as described in chapter 8.4.1
- Jack up the mobility aid using several wooden blocks. Use proper lifting techniques.
- Fit the reinforcement plates (7) (8) by attaching the reinforcement plate (8) with the screws (5) and (6) to the chassis (see picture on page 181).
- Calculate the required screw and choose the correct screws (4).
- Fit the spacers (2), the safety plate (3) and the special nuts (9).
- Fit the Allen screws (4) with a high-strength screw blocker system such as Loctite 270.
- Fit the batteries, as described in chapter 8.4.1.

**Note**

Fit new retaining plates (10) including screws and washers.

- Fit the remaining parts in the reverse order.
- To conclude, check all fittings for secure connection.

Removing the DAHL Docking Station:

- Disassemble the parts in reverse order than described in chapter "Fitting the DAHL Docking Station".

9.5 Fitting the stick holder

**Requirements:**

- 5 mm Allen key
- Phillips screwdriver size 2

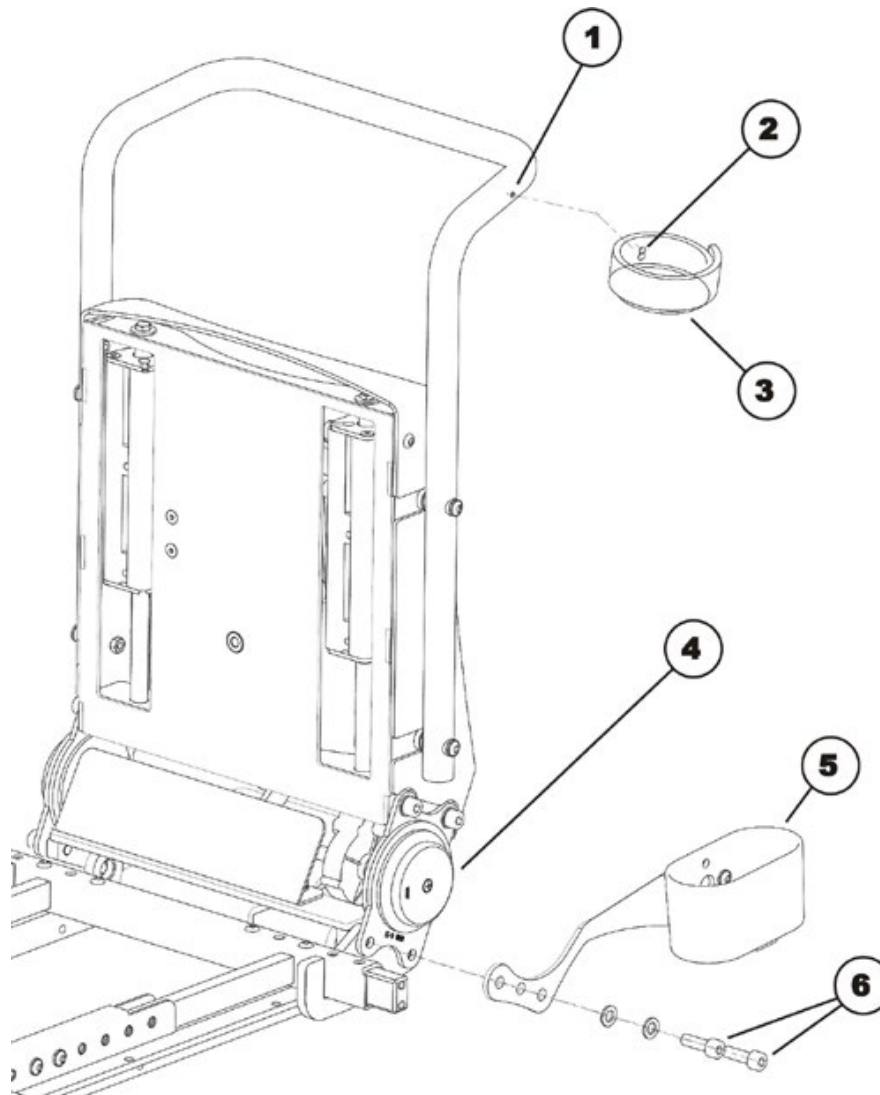

- Insert the Phillips screw (2) through the borehole of the loop (3).
- Attach the Phillips screw and the loop to the borehole (1) of the handlebar and tighten the Phillips screw with a Phillips screwdriver.
- Loosen and remove the two Allen screws (6) incl. the washers on the lower part of the backrest hinge (4).
- Hold the lower mounting (5) with the fastening holes in front of the boreholes of the backrest hinge.
- Refit the two Allen screws (6) incl. the washers and tighten the screws.

9.6 Further accessories



Note

The installation instructions for additional accessories are available at your Invacare® specialist supplier or directly from Invacare®.
