

Otto Bock Unterarmauflage / Otto Bock channel forearm pad / Otto Bock skålad underarmsdyna / Otto Bock avant-bras en gouttière / Otto Bock Apoio de braço côncavo e almofadado / Otto Bock Reposabrazos con forma / Otto Bock Supporto avambraccio / Otto Bock Hemiarm læn / Otto Bock Hemiplegi armlen / Otto Bock gootvormige onderarmlegger

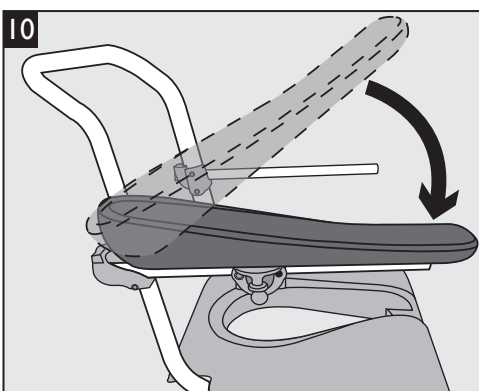
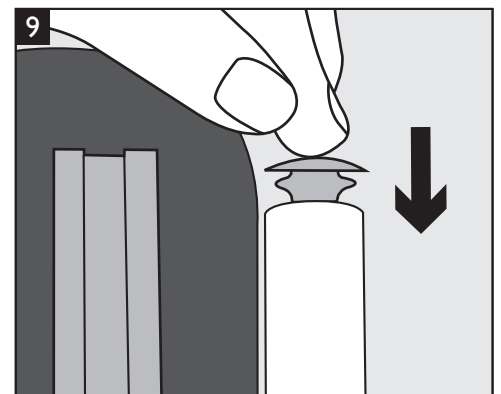
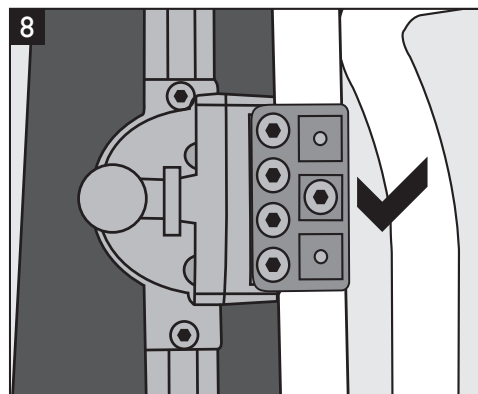
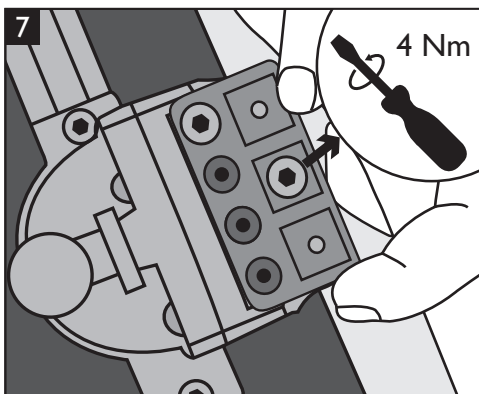
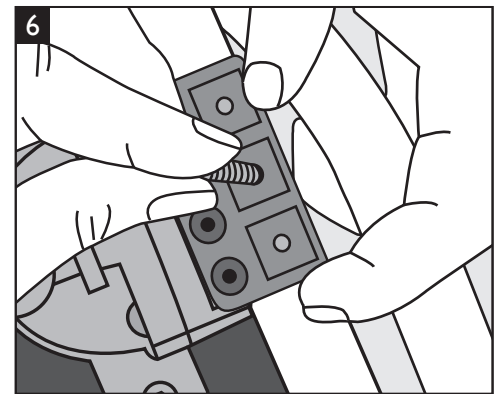
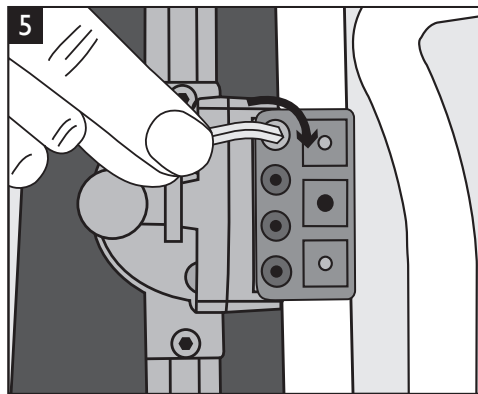
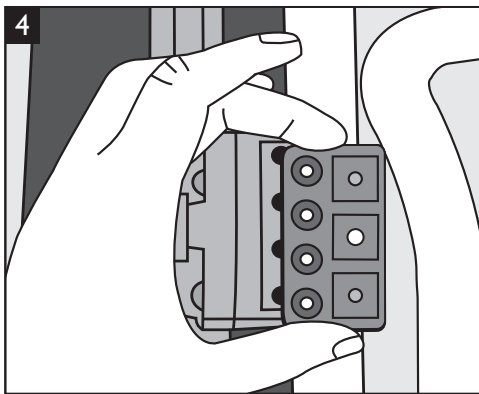
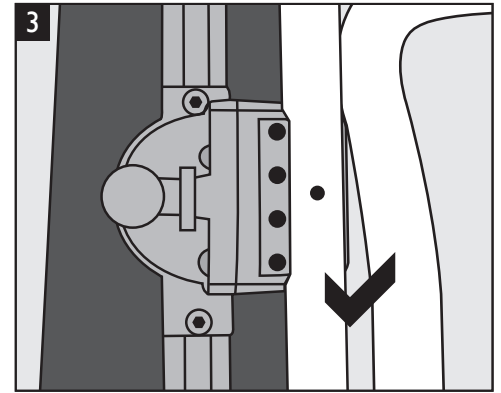
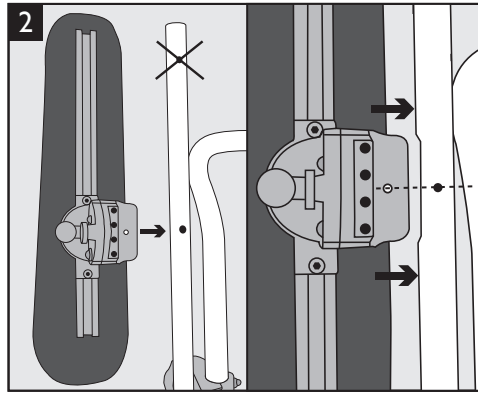
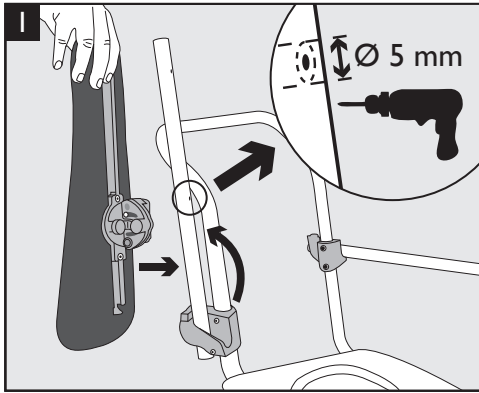

	<p>Nicht als Aufstiegshilfe benutzen / Do not use as a climbing aid / Ne pas utiliser comme aide à la montée / Non impiegare come ausilio di salita / No utilizar como elemento auxiliar de ascenso / Não utilizar como ajuda para subir / Niet als opstapje gebruiken / Får inte användas som upprensings-/överflyttningshjälpmedel / Ei saa käyttää nousuapuvälineenä / Må ikke brukes som påstigningshjelp / Må ikke anvendes til at stille sig op på</p>
	<p>Absturzgefahr / Danger of falling / Risque de chute / Pericolo di caduta / Peligro de caída / Perigo de queda / Gevaar voor vallen / Risk att ramla / Putoamisvaara / Fare for å falle / Fare for at falde ned</p>